

INFLUENCE OF Tl^+ ON THE Ca^{2+} AND Na^+ MOVEMENT ACROSS RAT NEONATAL CARDIOMYOCYTES AND RAT HEART MITOCHONDRIA MEMBRANES

S. M. KOROTKOV[✉], V. P. NESTEROV, G. B. BELOSTOTSKAYA,
I. V. BRAILOVSKAYA, A. V. NOVOZHILOV, C. V. SOBOL

Sechenov Institute of Evolutionary Physiology and Biochemistry, Russian
Academy of Sciences, St. Petersburg, Russian Federation;
[✉]e-mail: korotkov@SK1645.spb.edu

Received: 05 September 2019; Accepted: 29 November 2019

Thallium is known to produce one of the most complex and serious patterns of toxicity, involving a wide range of human organs and tissues. The toxic impact on biologic organisms is linked especially to the ability of Tl^+ to disturb calcium homeostasis and to permeate easily the inner mitochondrial membrane (IMM). The aim of this work was to study the effects of Tl^+ on intracellular Ca^{2+} dynamics in rat neonatal cardiomyocytes as well as on sodium penetrability of the IMM and Tl^+ -induced mitochondrial permeability transition pore (MPTP) opening in isolated Ca^{2+} -loaded rat heart mitochondria (RHM). The use of the fluorescent calcium indicator Fura 2 AM showed that Tl^+ induced calcium influx across the plasmatic membrane, resulting in calcium ($[Ca^{2+}]_i$) increase in the cytoplasm. This increase was even more pronounced in experiments with accelerating of Tl^+ -transmembrane fluxes by nonactin. It was nevertheless abolished by the removal of extracellular Ca^{2+} ions, but was not inhibited by a calcium-channel blocker (nifedipine). Tl^+ did not release calcium from the intracellular stores. Tl^+ potentiated sodium permeability of the IMM because swelling of nonenergized RHM in medium containing $TlNO_3$ and $NaNO_3$ was enhanced at high Tl^+ concentration. The calcium load of RHM induced MPTP opening which was accompanied by the increase of the swelling as well as the decrease of the inner membrane potential and of state 4_0 (basal) and state $3U_{DNP}$ (2,4-dinitrophenol-uncoupled) respiration. These effects of Tl^+ were suppressed by MPTP inhibitors (cyclosporine A, ADP and n-ethylmaleimide). The data obtained showed that Tl^+ -stimulated influx of extracellular calcium into cardiomyocytes could cause calcium and sodium RHM overload, which lead to the MPTP opening, thus determining the sensitivity of heart muscle to thallium intoxication.

Key words: Tl^+ , Ca^{2+} , Na^+ , cardiomyocytes, rat heart mitochondria, mitochondrial permeability transition pore (MPTP).

Thallium produces one of the most complex and serious patterns of toxicity known to humans, involving a wide range of organs and tissues. Tl^+ is a K^+ surrogate, owing to a similarity in ion radii, and it belongs to the group of trace elements which easily penetrate the skin and respiratory and digestive systems of mammals [1]. In the human body, thallium is absorbed mainly into the liver, spleen, kidneys, colon and the myocardium [2]. The severity of symptoms depends on the time and level of exposure, the rate of absorption, age,

and individual susceptibility [3]. Tl^+ can stoichiometrically replace K^+ in preparations of rat heart and diaphragm [4]. The $^{201}Tl^+$ isotope is used in medical procedures as a radioisotope in clinical cardiology, heart and tumor imaging, in planar and SPECT imaging, myocardial perfusion and cellular dosimetry [5-7]. Thallium compounds have been used in the manufacture of optical glass, and also as a homicidal agent and a rodenticide [1]. Tl^+ suppresses the heart-beat markedly [4]. In Tl -poisoned rats, thallium is stored in the heart and skeletal muscle more than in

the liver, kidney, or skin [8-11]. At the same time, considerable structural damage and grains were observed in SR, nuclei, myofibrils, and mitochondria of the rats. Additionally, cell muscle granules were deprived of glycogen. The toxic impact on biologic organisms is linked to the ability of Tl^+ to permeate easily the inner mitochondrial membrane (IMM) and to substitute K^+ in K^+ -dependent biochemical reactions or transport processes [1, 12].

It is generally known that a moderate calcium load of mitochondria facilitates the appearance of the permeability transition pore (MPTP) in the inner mitochondrial membrane (IMM) [13]. In this case, the MPTP is in a low conductance state, and the IMM becomes penetrable to H^+ , K^+ , Na^+ , and Ca^{2+} with massive mitochondrial swelling and decreased membrane potential ($\Delta\Psi_{mito}$). It was previously found that Tl^+ raised the concentration of Ca^{2+} and Na^+ in isolated rat hepatocytes [14]. The calcium load of succinate-energized rat liver mitochondria (RLM) in medium containing $TlNO_3$ and nitrates (KNO_3 , $NaNO_3$, NH_4NO_3) caused Tl^+ -induced MPTP opening in their inner membrane. This was manifested as an increase in swelling and a decrease in both $\Delta\Psi_{mito}$ and state 4, state 3, and state $3U_{DNP}$ (2,4-dinitrophenol (DNP)-stimulated) respiration [15]. The Tl^+ -induced MPTP with the latter three effects was found in similar experiments with Ca^{2+} -loaded RHM, injected into medium containing $TlNO_3$ and KNO_3 [16]. The opening of the MPTP in calcium-loaded RLM and RHM, as well as the decrease in both $\Delta\Psi_{mito}$ and respiration, and the increase in swelling were slowed down in the presence of MPTP inhibitors (ADP and cyclosporin A (CsA)) [15, 16]. The effects of Tl^+ have not been investigated in intracellular calcium in cardiac myocytes. There are no data on the joint effect of Ca^{2+} and Na^+ on the Tl^+ -induced MPTP opening in the inner membrane of RHM. The aim of this work is to study the effects of Tl^+ on intracellular Ca^{2+} dynamics in rat neonatal cardiomyocytes. Another goal of our work was to study the effect of Tl^+ on both the sodium penetrability of the IMM and the Tl^+ -induced MPTP in Ca^{2+} -loaded rat heart mitochondria. We, therefore, examined the swelling, $\Delta\Psi_{mito}$ decrease, as well as state 4₀, state 3, and state $3U_{DNP}$ respiration in the RHM in medium containing $TlNO_3$ and $NaNO_3$ in the presence of Ca^{2+} as well as the MPTP inhibitors (CsA, ADP, n-ethylmaleimide (NEM)).

Materials and Methods

Animals. Female and male Wistar rats (250-300 g) were used in the research. The animals were kept at 20–23 °C under 12-h light/dark cycle with free access to the standard rat diet and water ad libitum. All treatment procedures of animals were performed in accordance with the Animal Welfare act and the Institute Guide for Care and Use of Laboratory Animals.

Chemicals. The reagents for cell culturing were purchased from Biolot (St. Petersburg, Russia). Mannitol, $Mg(NO_3)_2$, $CaCl_2$, H_3PO_4 , $TlNO_3$, $NaCl$, $NaNO_3$, NH_4NO_3 , and DNP were of analytical grade. Rotenone, oligomycin, CsA, safranin, Tris-OH, ethylene glycol-bis(β -aminoethyl ether) N,N,N',N'-tetraacetic acid (EGTA), ADP, glucose, HEPES, succinate, $MgCl_2$, NEM, type IA collagenase, Fura 2 AM, and free fatty acid albumin of bovine serum (BSA) were from Sigma (St. Louis, MO, USA). The BSA (Minsk, Belarus) was used for the preparation of an isolation medium I. Sucrose as 1 M solution was refined from cation traces on a column filled with a KU-2-8 resin from Azot (Kemerovo, Russia).

Cultivation of rat neonatal cardiomyocytes. Methods of cultivation and Ca^{2+} registration have been described in detail [17]. Briefly, newborn Wistar rats (1-day-old) were used for the preparation of the myocytes' culture. Rats were subjected to carbon dioxide. Dissected hearts were thoroughly disintegrated and incubated at 37 °C for 40–50 min in Ringer's solution for rodents: 146 mM $NaCl$, 5 mM KCl , 2 mM $CaCl_2$, 1 mM $MgCl_2$, 11 mM glucose, 10 mM HEPES (pH 7.4), containing type IA collagenase (1 mg/ml, Sigma) and trypsin (0.12%, Biolot, Russia). After filtration and centrifugation at 1000 rpm for 10 min, the cells were resuspended in the medium containing DMEM medium with 10% fetal serum, 50 IU/ml penicillin and 50 μ g/ml of streptomycin. Nonmuscular cells were deleted with a preliminary incubation on a Petri dish over 40–50 min at 37 °C. Non-attached cells were then incubated on cover slips (12×24 mm) covered with a poly-D-lysine (0.1 mg/ml, MP Biomedicals, USA). The cells were incubated in a CO_2 incubator (Jouan, France) at 5% of CO_2 , a humidity of 95% and at 37 °C. The medium was replaced every two days. The cells were cultured for 5–10 days before the experiments.

Measurements of intracellular calcium. Cover slips with cells were loaded in Ringer's solution for rodents with Fura 2 AM at a concentration of 5 μM for 1 h at 26 °C. Then, cells were washed with a Ringer's solution for 30 min and the intracellular calcium concentration ($[\text{Ca}^{2+}]_i$) was measured at room temperature on cover slips placed above an inverted microscope lens. Nonactin of 1 μM we used to enhance the entrance of Tl^+ into the cardiomyocytes (Fig. 1). During Ca^{2+} experiments in Ca^{2+} -free EGTA solution, all Ca^{2+} was replaced with 2 mM EGTA (Fig. 3). $[\text{Ca}^{2+}]_i$ was measured using a computer analysis system for intracellular ion content (Intracellular Imaging & Photometry System, USA), with inverted microscope Nikon TMS (objective $\times 30$) and monochrome digital video camera, RS_170 CCD (Cohu Inc., USA). The cells were excited with light at wavelengths of 340 and 380 nm, and emission was registered at 510 nm. The built-in computer InCytIm2TM software allowed measuring the intracellular calcium ion concentration as the ratio of the fluorescence emission intensities excited at 340 and 380 nm (F_{340}/F_{380}), using a calibration curve based on calibration solutions (Fluka Chemicals) with known Ca^{2+} concentrations.

Mitochondrial isolation. Rat heart mitochondria were isolated from Wistar adult male rats (200–250 g) according to procedure which explicated more detail in Korotkov et al. [16]. The rat hearts were minced, washed, and homogenized by using an MPW-302 polytron homogenizer from Mechanika Precyzyjna (Warsaw, Poland) in the medium I containing 70 mM sucrose, 220 mM mannitol, 2 mM EGTA, 10 mM Tris-HCl (pH 7.3), and 0.1% BSA (Minsk, Belarus). To precipitate non-homogenized tissue particles, the homogenate was then centrifuged for 10 min at 400 g by a K-24 centrifuge (Germany). Further, the containing mitochondria supernatant centrifuged for 10 min at 8500 g and the RHM sediment was kept on ice. To increase the number of mitochondria, the tissue particles were repeatedly homogenized by using a potter homogenizer with Teflon pestle. Next, the tissue homogenate and the supernatant were successively centrifuged at 400 and 8500 g, accordingly. This procedure was performed twice. At the final stage, the RHM sediment obtained from the three cycles was twice rinsed out in a medium II containing 300 mM sucrose, 10 mM Tris-HCl (pH 7.3), 5 μM EGTA, and 0.1% BSA (Sigma, USA) with followed the RHM sedimentation for 10 min at 6500 g. All the above procedures were per-

formed on ice. The protein concentration tested by the Bradford method was 25–30 mg/ml.

Mitochondrial swelling. Swelling of the RHM was evaluated by a decrease in the apparent absorbance of mitochondrial suspension at room temperature on an SF-46 spectrophotometer (LOMO, St. Petersburg, Russia) at 540 nm. Mitochondria (1.0 mg/ml of protein) were administrated in 1-cm cuvette with 1.5 ml of sucrose-adjusted 400 mOsm medium containing 0–75 mM TiNO_3 (Fig. 4, a) or 25 mM TiNO_3 , 100 mM sucrose, 1 mM Tris-PO_4 , and 200 μM CaCl_2 (Fig. 4, b). All media above contained 125 mM NaNO_3 , 5 mM Tris-NO_3 (pH 7.3), 2 μM rotenone, and 1 $\mu\text{g/ml}$ of oligomycin. The following agents were administered into the medium before addition of mitochondria (where indicated): 0.5 mM ADP, 1 μM CsA, and 50 μM NEM. The concentrations of other additions showed in the figure legends. The swelling, respiration rates and $\Delta\Psi_{\text{mito}}$ were tested in the 400 mOsm media in order to check the comparability and consistency between the events in different experiments. The media osmolality was fixed by sucrose addition.

Oxygen consumption assay. The oxygen consumption rates (ng atom O/min per mg of protein) were tested polarographically using Expert-001 analyzer (Econix-Expert Ltd., Moscow, Russia) in a 1.3-ml closed thermostatic chamber with magnetic stirring at 26 °C (Fig. 5 and 6). Mitochondria (1.0 mg/ml of protein) were added into the 400 mOsm medium containing 0–75 mM TiNO_3 (Fig. 5), 125 mM NaNO_3 (a), or 125 mM NH_4NO_3 (b). Alternative medium contained 25 mM TiNO_3 (Fig. 5), 100 mM sucrose, 125 mM NaNO_3 (c), or 125 mM NH_4NO_3 (d), and 1 $\mu\text{g/ml}$ of oligomycin. Besides the media above contained 5 mM succinate, 5 mM Tris-NO_3 (pH 7.3), 2 μM rotenone, 3 mM Tris-PO_4 , and 3 mM $\text{Mg}(\text{NO}_3)_2$. ADP of 200 μM or DNP of 15 μM were injected into the media after 2 min recording of state 4₀ (basal) to induce state 3 or state 3U_{DNP} (DNP-stimulated) respiration [18], accordingly (Fig. 5). Additions after mitochondria (ADP, CsA, NEM, and Ca^{2+}) are specified in the Figures legend. The respiratory control ratios (RCR and RCR_{DNP}) are correspondingly relation of state 3 rate to state 4₀ rate or state 3U_{DNP} rate to state 4₀ rate.

Mitochondrial membrane potential. The $\Delta\Psi_{\text{mito}}$ induced by 5 mM succinate on the inner membrane of the RHM (Fig. 6) was evaluated according to Waldmeier et al. [19]. We measured intensity of safranin fluorescence (arbitrary units) in the mito-

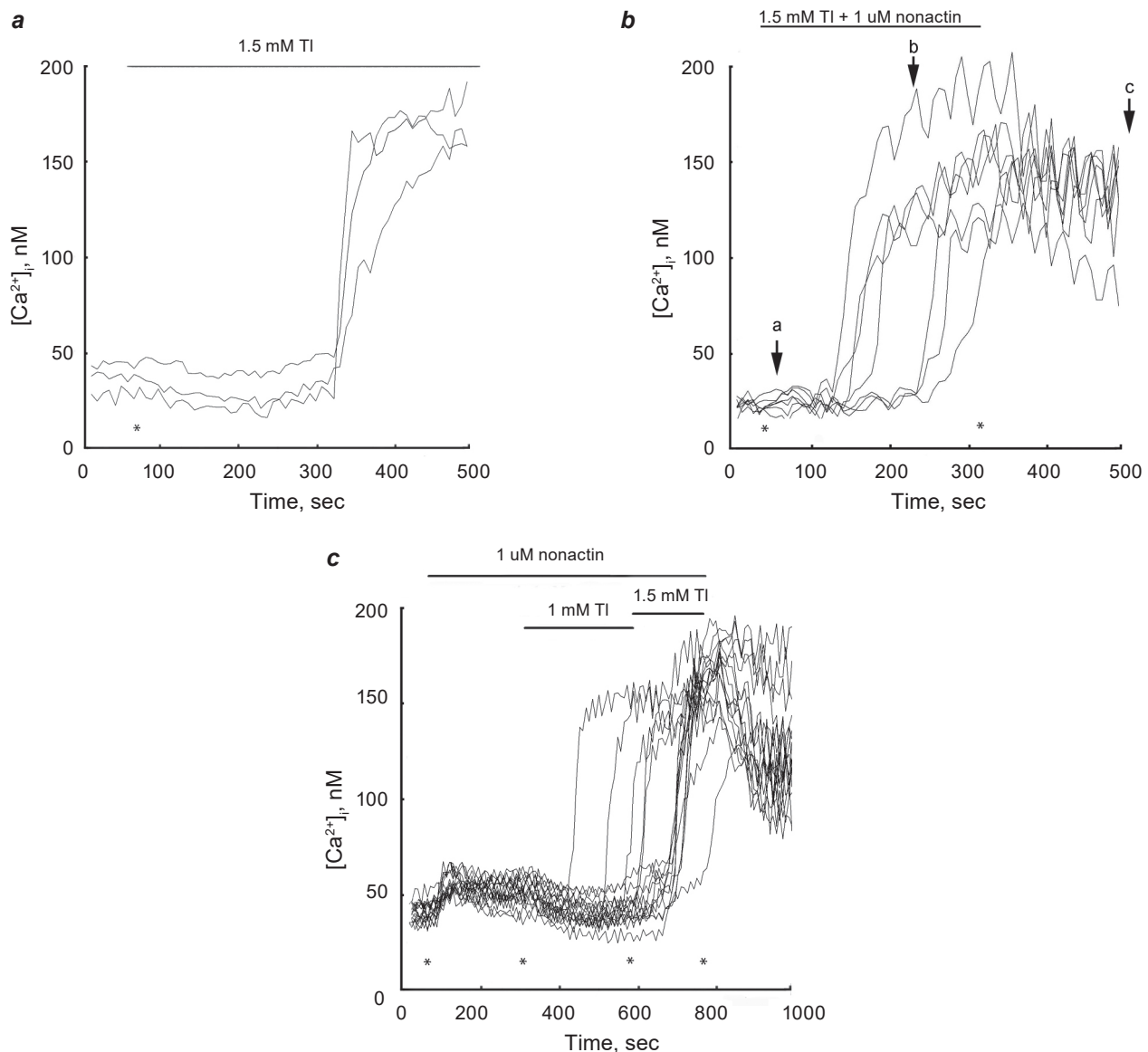

Fig. 1. Influence of Tl^+ and nonactin on cytoplasmic calcium concentration in rat neonatal myocytes. Cells were exposed to 1.5 mM Tl^+ without (panel a, $n = 3$) or with 1 μ M nonactin (panel b, $n = 8$). The duration of Tl^+ application is indicated by a horizontal line. Each trace is the calcium signal from one cell. In one experiment, we used one single coverslip with cells. Similar results to the ones depicted were replicated in three to four independent experiments. The abscissa is the time in seconds. The ordinate is the intracellular calcium concentration, $[Ca^{2+}]_i$ (nM). Below the chart, asterisks indicate the time of application of appropriate solutions, which are indicated by the lines above the figure. Similar results were found in 3 independent experiments

chondrial suspension with magnetic stirring at room temperature using a Shimadzu RF-1501 spectrophotofluorimeter (Shimadzu, Germany) at 485/590 nm wavelength (excitation/emission). Mitochondria (0.5 mg protein/ml) were injected into totally clear quartz cuvette with 3 ml of 400 mOsm medium containing 15 mM $TlNO_3$, 120 mM sucrose, 125 mM $NaNO_3$ (a), or 125 mM NH_4NO_3 (b), 5 mM Tris- NO_3 (pH 7.3), 1 mM Tris- PO_4 , 3 μ M safranin, 2 μ M ro-

tenone, and 1 μ g/ml of oligomycin. ADP and CsA were put into the medium before the RHM (where shown). Additions of succinate, Ca^{2+} , and DNP are shown in the Fig. legend. The use of millimolar thallium(I) concentrations for our study was due to the specifics of isolated mitochondria research that was our discussed earlier [20, 21].

Statistical analysis. Data are presented from at least three independent experiments, with 5–25 cells

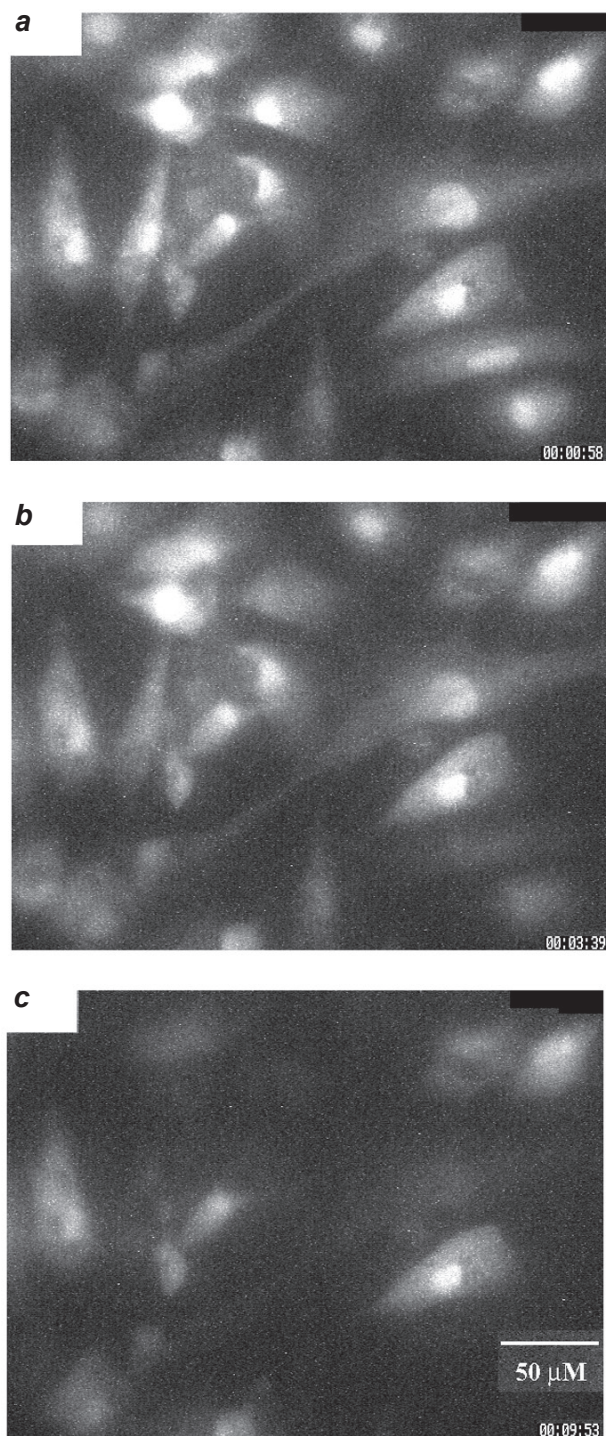

Fig. 2. Effects of Tl^+ on a fluorescence in rat neonatal myocytes. The fluorescence at 380 nm on panels **a-c** was correspondingly registered at the time indicated by arrows **a**, **b** and **c** in Fig. 1, **b**. Panel **a** – fluorescence at the start of the experiment (arrow **a**). Panels **b** and **c** – fluorescence at the times indicated by the arrows **b** and **c** in Fig. 1, **b**, respectively

in each experiment. The means \pm s.e.m. are shown. N is the number of experiments, n is the number of cells. The statistical differences in results and corresponding P -values were evaluated using two population t -test (Microcal Origin, Version 6.0, Microcal Software). These differences are presented as percent of the average ($P < 0.05$) from one of three independent experiments (Fig. 1-6).

Results and Discussion

Tl^+ induces an increase in $[Ca^{2+}]_i$ in cardiomyocytes. In our experiments with rat neonatal cardiomyocytes, we used Tl^+ concentrations comparable to those used in other studies [4, 17, 22, 23]. An increase of $[Ca^{2+}]_i$ was observed in the myocytes after 300-400 sec of Tl^+ application (Fig. 1, **a**). To enhance the entrance of Tl^+ into the cardiomyocytes, we used nonactin which was found to be markedly increased Tl^+ penetration into energized rat liver mitochondria [12, 20, 24]. It has previously been shown that cardiomyocytes were killed after application of nonactin [25]. We, therefore, used essentially a low concentration of nonactin (1 μ M) and a short exposure time of 16 min maximum. Experiments with nonactin showed that the Tl^+ -induced Ca^{2+} increase occurred in a shorter time (by 100-200 sec) after Tl^+ nonactin application (Fig. 1, **b** and **c**). The effects of 1 μ M nonactin (Fig. 1, **c**) on $[Ca^{2+}]_i$ at the beginning of the experiments and before Tl^+ application were minor and transient, and were seen within a short time span (100-200 sec). Only $19 \pm 2\%$ of the cells responded to nonactin ($n = 37$, $N = 3$). The effects of Tl^+ on $[Ca^{2+}]_i$ dynamics were dependent on the Tl^+ concentration and duration of Tl^+ application (Fig. 1, **c**). For example, 10 ± 2 and $55 \pm 3\%$ of the cells in the presence of 1 μ M nonactin responded to 1 mM Tl^+ and 1.5 mM Tl^+ ($n = 79$, $N = 3$) respectively. It should be noted that the cardiomyocytes did not respond to Tl^+ simultaneously. The **a-c** images of cardiomyocytes loaded with Fura 2 AM and fluorescing at 380 nm (Fig. 2) are correspondingly shown at the times indicated by arrows **a**, **b** and **c** in Fig. 1, **b**. The fluorescent signal of F_{380} was not recovered after the end of Tl^+ exposure (Fig. 2, **c**). This may be due to the extrusion of Fura 2AM through the plasmalemmal pore(s), which may be formed after Tl^+ application.

Experiments in Ca^{2+} -free EGTA solution. In our experiments, the Ca^{2+} in the extracellular solution was replaced by 2 mM EGTA before (Fig. 3, **a**) and after (Fig. 3, **b**) the addition of Tl^+ . The extracellular

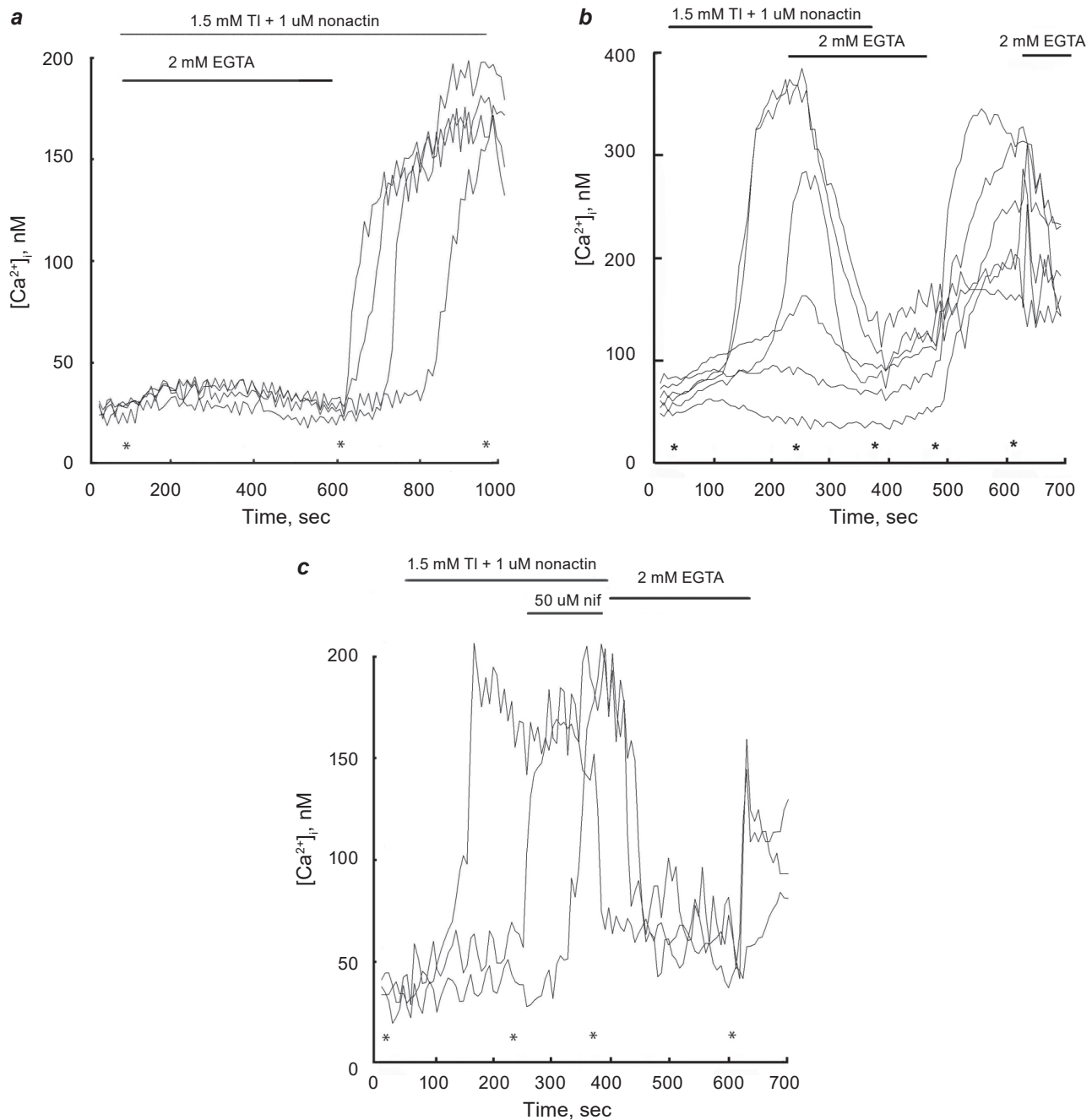

Fig. 3. Effects of Tl^+ , Ca^{2+} -free EGTA solution and nifedipine on cytoplasmic calcium concentration in rat neonatal myocytes. Cells were treated by 1.5 mM Tl^+ in Ca^{2+} -free EGTA solution, which was added before (panel a, $n = 4$) or after Tl^+ application (panel b, $n = 6$) or 1.5 mM Tl^+ , and subsequently in nifedipine (50 μM) and Ca^{2+} -free EGTA solution applications (panel c, $n = 4$). In Ca^{2+} -free EGTA solution, all Ca^{2+} was replaced with 2 mM EGTA. Other designations are the same as in Fig. 1. Similar results were found in 3 independent experiments

Ca^{2+} was subsequently restored to 2 mM (Fig. 3, a, b). As shown in Fig. 3 (a), Tl^+ did not induce $[Ca^{2+}]_i$ release from intracellular stores. When Ca^{2+} influx was inhibited in Ca^{2+} -free EGTA solution, the sustained increase in Ca^{2+} stimulated by application of

Tl^+ was absent (Fig. 3, b). After restoration of extracellular Ca^{2+} , an increase in $[Ca^{2+}]_i$ was observed (Fig. 3, b). To find out which Ca^{2+} channels are responsible for the entrance of Tl^+ , we used plasmatic L- Ca^{2+} -channels blocker, nifedipine at a concentra-

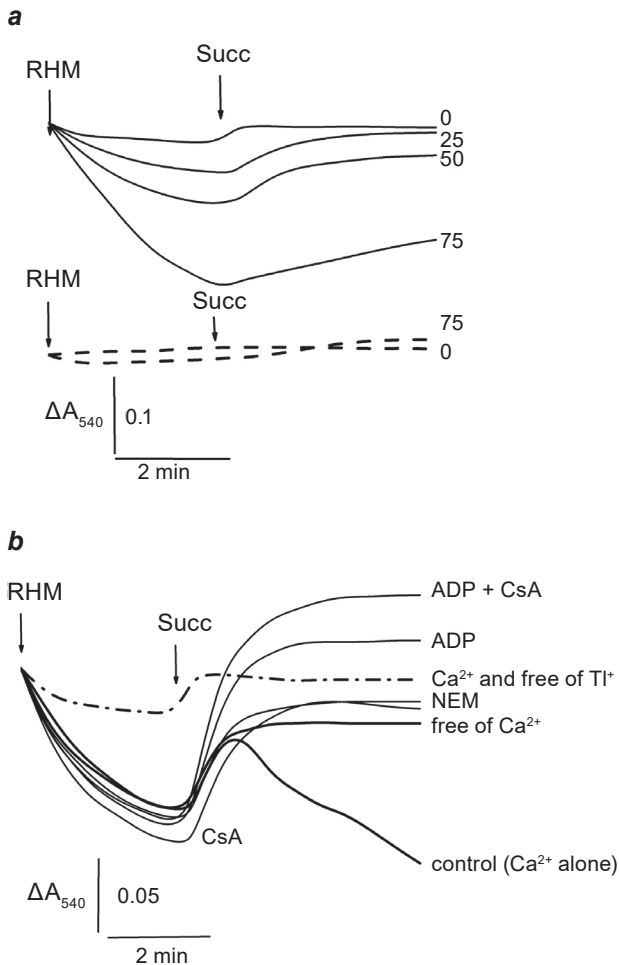

Fig. 4. Effects of Tl^+ on swelling of rat heart mitochondria. Mitochondria (1.0 mg/ml of protein) were administered to the sucrose-adjusted 400 mOsm medium containing (panel **a**) 0–75 mM $TlNO_3$ as well as 125 mM $NaNO_3$ or 250 mM sucrose (dash traces); (panel **b**) 25 mM $TlNO_3$ and 100 mM sucrose or 150 mM sucrose free of Tl^+ (dash dot trace) as well as 125 mM $NaNO_3$, 300 μM Ca^{2+} , and 1 mM $Tris-PO_4$. The medium also contained 5 mM $Tris-NO_3$ (pH 7.3), 2 μM rotenone, and 1 $\mu g/ml$ of oligomycin. Numbers near the traces (panel **a**) show concentration of $TlNO_3$ (mM) in the medium. Bold traces (panel **b**) correspondingly indicate experiments with Ca^{2+} alone (control) or free of Ca^{2+} . The effectors (panel **b**) added before mitochondria into the medium are indicated on the right of the traces: 1 μM CsA (CsA); 0.5 mM ADP (ADP); and 50 μM NEM (NEM). Additions of mitochondria (RHM) and 5 mM succinate (Succ) are shown by arrows. Typical traces for three different mitochondrial preparations are presented

tion of 50 μM , which had no effect on Ca^{2+} influx stimulated by Tl^+ application (Fig. 3, c).

Effects of Tl^+ and Ca^{2+} on swelling of rat heart mitochondria in nitrate media. Brierley et al. [26] earlier showed that the IMM passive sodium permeability can be estimated by the swelling of non-energized mitochondria in medium containing $NaNO_3$ because the IMM is free penetrable to NO_3^- anion. It is known that mitochondrial respiratory enzymes (NADH-, succinate-, and malate dehydrogenase) poorly inhibited by Tl^+ millimolar concentrations since Tl^+ showed a weak interaction with molecular thiol groups [27], and it is this fact that was the main reason for the use of millimolar Tl^+ concentrations [9, 28] in experiments with isolated mitochondria what we explained previously in more detail [20]. Earlier, we found that Tl^+ increased the permeability in experiments with RLM, injected into 400 mOsm medium containing 0–75 mM $TlNO_3$ and 125 mM $NaNO_3$ [29]. The swelling of non-energized RHM increased steadily when the $TlNO_3$ concentration was increased in the medium (Fig. 4, a). However, the swelling was almost not observed when 125 mM $NaNO_3$ in the medium was replaced by 250 mM sucrose (bold dash traces). Injection of succinate caused these organelles to contract, but the contraction abated when 75 mM $TlNO_3$ were added (Fig. 4, a). The calcium load of mitochondria is accompanied by massive swelling of these organelles, due to opening of the mitochondrial permeability transition pore (MPTP) in the inner membrane [13]. Swelling of succinate-energized rat liver mitochondria in medium with $TlNO_3$, 125 mM nitrates (KNO_3 , NH_4NO_3 , $NaNO_3$) and 100 μM Ca^{2+} was caused by the opening of the MPTP in the inner membrane [29]. The 3-minute swelling of non-energized rat heart mitochondria (RHM) in medium containin 25 mM $TlNO_3$ and 125 mM $NaNO_3$ (Fig. 4, b) was not affected by 300 μM Ca^{2+} (control trace with Ca^{2+} alone) nor by the MPTP inhibitors (ADP, CsA, NEM). The addition of succinate resulted in massive mitochondrial swelling (control trace) which was followed by mitochondrial contraction, increased in series CsA, NEM < ADP < ADP + CsA (Fig. 4, b).

Influence of Tl^+ and Ca^{2+} on oxygen consumption rates of rat heart mitochondria and the inner membrane potential in nitrate media. State 4₀ of succinate-energized RHM was diminished in medium containing 50–75 mM $TlNO_3$ and 125 mM $NaNO_3$

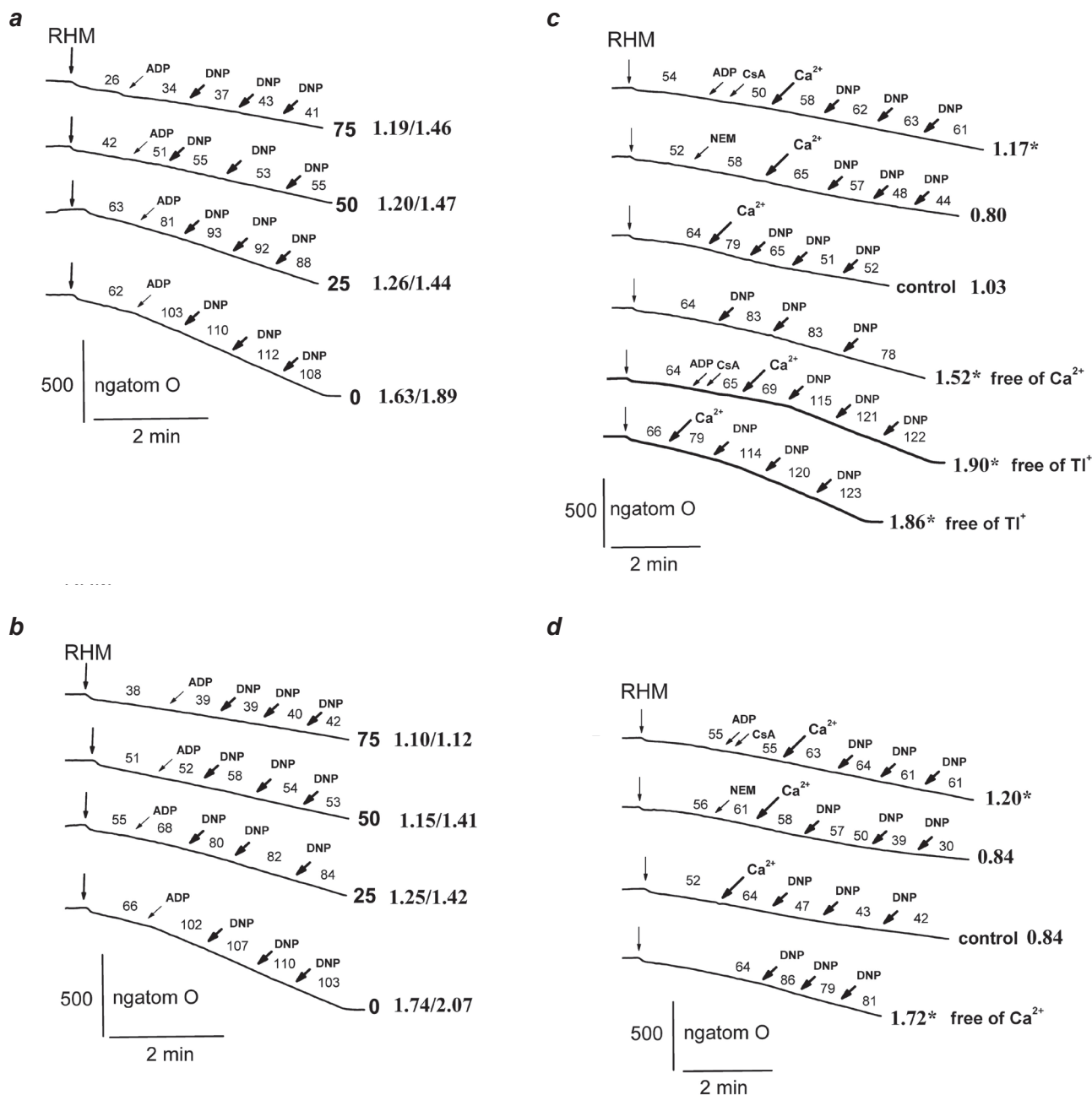

Fig. 5. Effects of Tl^+ , Ca^{2+} and effectors on oxygen consumption rates of rat heart mitochondria. Mitochondria (1.0 mg/ml of protein) were injected in 400 mOsm medium containing 0-75 mM $TlNO_3$ (a,b) or 25 mM $TlNO_3$ and 100 mM sucrose (c,d) or 150 mM sucrose alone in bold traces (c), as well as 5 mM succinate, 5 mM Tris- NO_3 (pH 7.3), 2 μ M rotenone, 3 mM Tris- PO_4 , and 3 mM $Mg(NO_3)_2$. Additionally, the medium was supplemented 125 mM $NaNO_3$ (a,c) or 125 mM NH_4NO_3 (b,d), as well as 1 μ g/ml of oligomycin (c,d). Additions of mitochondria (RHM), 300 μ M (a,b) ADP (ADP), 75 μ M Ca^{2+} (Ca^{2+}), and three ones of 5 μ M DNP (DNP) are accordingly shown by vertical arrows, inclined arrows, and inclined bold arrows. The injection of the effectors (c,d) is shown by inclined arrows: control (Ca^{2+} alone and free of effectors), 1 μ M CsA (CsA); 0.5 mM ADP (ADP), and 50 μ M NEM (NEM). Oxygen consumption rates (ng atom O min/mg of protein) are presented as numbers placed above experimental traces. Bold numbers near the traces show (a,b) concentration of $TlNO_3$ (mM) in the medium. Numbers near the traces correspondingly indicate value of the RCR/the RCR_{DNP} (a,b) or the RCR_{DNP} (c,d) (see the Materials and Methods). Typical traces for three different mitochondrial preparations are presented

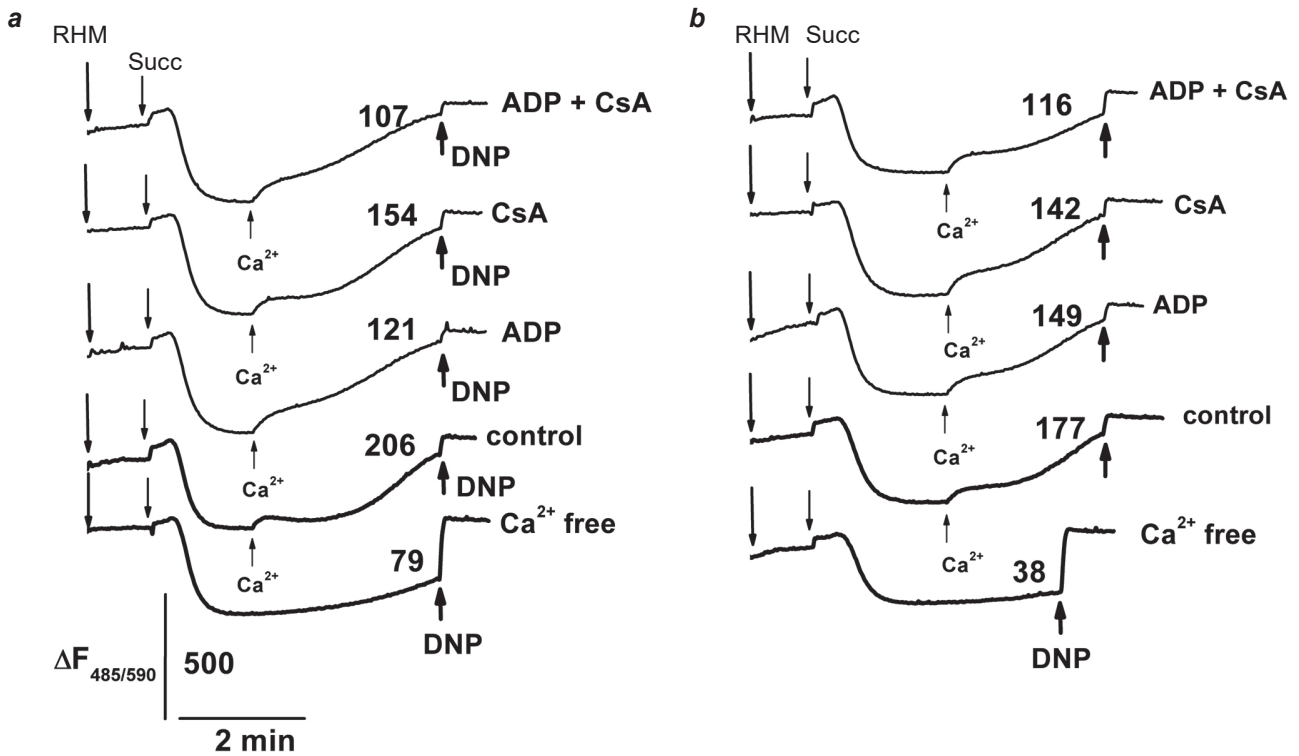

Fig. 6. Effects of Tl^+ and Ca^{2+} on the inner membrane potential ($\Delta\Psi_{mito}$) of rat heart mitochondria. Mitochondria (0.5 mg/ml of protein) were added to medium containing 15 mM $TlNO_3$, 120 mM sucrose, 5 mM Tris- NO_3 (pH 7.3), 1 mM Tris- PO_4 , 3 μ M safranin, 2 μ M rotenone, and 1 μ g/ml of oligomycin as well as 125 mM $NaNO_3$ (panel a) or 125 mM NH_4NO_3 (panel b). Down-directed arrows show additions of mitochondria (RHM) and 5 mM succinate (Succ). Injections of 30 μ M Ca^{2+} (Ca^{2+}) and 40 μ M DNP (DNP) are demonstrated by up-directed bold arrows. Additions before mitochondria are indicated on the right of the traces: 1 μ M CsA (CsA) and 0.5 mM ADP (ADP). Bold traces render experiments with Ca^{2+} (control) or those free of Ca^{2+} . The rates of Ca^{2+} -induced $\Delta\Psi_{mito}$ dissipation (arbitrary units per min) are shown as numbers placed above experimental traces. Typical traces for three different mitochondrial preparations are presented

(Fig. 5, a) or 25–75 mM $TlNO_3$ and 125 mM NH_4NO_3 (Fig. 5, b), correspondingly. When the $TlNO_3$ concentration was raised from 25 to 75 mM, state 3 and state $3U_{DNP}$ respiration of RHM diminished in medium containing $NaNO_3$ (Fig. 5, a) or NH_4NO_3 (Fig. 5, b). Compared with experiments free of Ca^{2+} (Fig. 5 and 6 (free of Ca^{2+} trace)), a decrease in state $3U_{DNP}$ respiration (control trace with Ca^{2+} alone) and in RCR_{DNP} was found after administration of 100 μ M Ca^{2+} in the 400 mOsm medium with 25 mM $TlNO_3$ and 100 mM sucrose, as well as with 125 mM $NaNO_3$ (Fig. 5, c) or 125 mM NH_4NO_3 (Fig. 5, d). The decrease in the respiration and in RCR_{DNP} was counteracted notably in the presence of MPTP inhibitors (ADP and CsA) but the decrease remained constant in experiments with NEM (Fig. 5). When 25 mM $TlNO_3$ was replaced by 50 mM sucrose in the medium with 125 mM $NaNO_3$ (Fig. 5, c, free of

Tl^+ traces), state $3U_{DNP}$ respiration and RCR_{DNP} after Ca^{2+} injection and regardless of ADP with CsA additions (bold traces) were similar to ones found in like experiments with this medium without Ca^{2+} (Fig. 5, a). The decrease of $\Delta\Psi_{mito}$ on the inner membrane of RHM (Fig. 6) was not so strong (free of Ca^{2+} trace) after administration of succinate into the 400 mOsm medium containing 15 mM $TlNO_3$ and 110 mM sucrose together with 125 mM $NaNO_3$ (Fig. 6, a) or 125 mM NH_4NO_3 (Fig. 6, b). The $\Delta\Psi_{mito}$ decrease after injection of Ca^{2+} into the medium (control trace with Ca^{2+} alone) revealed a notable acceleration, which was clearly eliminated in experiments with the MPTP inhibitors (ADP + CsA).

L-type Ca^{2+} channels are believed to be the main transporter for the trans-sarcolemmal Ca^{2+} influx in adult cardiomyocytes. The impact of Tl^+ on isolated hepatocytes was accompanied by an in-

crease in cytosolic concentrations of Ca^{2+} [14]. We, therefore, anticipated that Tl^+ could also stimulate this pathway. Talbot [23] found that Tl^+ entered the nerve terminal primarily via Ca channels. While nifedipine ($> 2 \mu\text{M}$) blocked the Ca^{2+} transients in cardiomyocytes [30], the influx of Ca^{2+} into rat neonatal cardiomyocytes in our experiments was not blocked in the presence of $50 \mu\text{M}$ nifedipine and 1.5 mM Tl^+ (Fig. 3, c). Thus, the mechanism of the Tl^+ -induced rise in $[\text{Ca}^{2+}]_i$ (Fig. 1, a) is likely not associated with Tl^+ activation of the L-type Ca^{2+} channels. It can be assumed that the fluxes of extracellular calcium are most likely due to the activation of the Ca^{2+} permeability pathway or calcium channels (other than L-type) in the plasma cell membrane, which causes the direct influx of Ca^{2+} into the cytoplasm.

Na^+/K^+ -ATPase catalyses transport of Tl^+ into myocytes [31, 32]. To stimulate the influx of Tl^+ into the cells, we used nonactin (Fig. 1, b and c). Earlier, it has been shown that cardiomyocytes were killed by the application of a high concentration of nonactin ($10 \mu\text{M}$) during a prolonged exposure time (60 min) [25]. Under these circumstances, 33% of the cardiomyocytes were killed [25]. In our experiments (Fig. 1, b and c) we used essentially a low concentration of nonactin ($1 \mu\text{M}$) and short exposure time, 16 min maximum. Nonactin was able to increase the cytoplasmic calcium concentration at $20\text{--}100 \mu\text{M}$ in non-excitable cells (the murine tumor cell lines) [33]. These authors suggested that the rise in $[\text{Ca}^{2+}]_i$ was most likely due to the release of calcium from intracellular stores, but they did not perform experiments with a Ca^{2+} free solution. Therefore, we conducted some experiments with nonactin alone to discover its ability to increase $[\text{Ca}^{2+}]_i$. We showed that the Ca increase induced by nonactin before Tl^+ application was rather low and transient (Fig. 1, c). Additionally, most of the cells did not respond to a $1 \mu\text{M}$ concentration of nonactin. It cannot be ruled out that nonactin, which stimulates both Tl^+ entrance into the cells, and the subsequent Tl^+ -induced Ca^{2+} increase, is able to facilitate Tl^+ -induced channel opening in the inner mitochondrial membrane.

Electro-physiological research has detected Tl^+ permeability in the SR channel [34]. Tl^+ ions had a selective impact on the muscle and its mitochondria, which are the main site of Tl^+ distribution [11]. Thallium interacts with the excitability of peripheral and myocardial muscle cells [1]. Some possible toxic mechanisms of Tl^+ can be the disturbance of calcium

homeostasis, inhibition of cellular respiration, as well as ligand formation of Tl^+ with protein sulfhydryl groups [1]. Our *in vitro* studies with RLM have revealed that Tl^+ was able to form complexes with mitochondrial proteins [35]. In our experiments, we observed that the inhibition of Ca^{2+} influx with Ca^{2+} -free EGTA solution prevented the sustained/transient increase in $[\text{Ca}^{2+}]_i$ induced by the addition of Tl^+ (Fig. 3, a). Thus, Tl^+ did not induce $[\text{Ca}^{2+}]_i$ release from intracellular stores. Addition of Ca^{2+} -free EGTA solution after a Tl^+ -induced calcium rise also led to a reduction in $[\text{Ca}^{2+}]_i$ almost to the resting level (Fig. 3, b). The reduction of Ca^{2+} in cardiomyocytes in Ca^{2+} -free EGTA solution implies that Ca^{2+} sequestration and extrusion mechanisms are still able to function after Tl^+ application. These mechanisms can be extrusion of $[\text{Ca}^{2+}]_i$ by both plasmalemmal sodium calcium exchanger and plasma membrane Ca^{2+} ATPase, and possibly mitochondrial Ca^{2+} uptake through the Ca^{2+} uniporter. Nevertheless, we believe that Tl^+ at 1.5 mM is toxic for cells, because we observed a dramatic loss of intracellular dye Fura 2AM (namely F_{380}) at the end of all experiments. The fluorescent signal of F_{380} was not recovered after the end of Tl^+ exposure (Fig. 2, c). This may be due to the extrusion of Fura 2AM through the plasmalemmal pore(s), which may be formed after Tl^+ application.

It is assumed that Tl^+ ions induced calcium overloading in the cardiomyocytes followed by channel opening in the inner mitochondrial membrane, and this may contribute to the toxic effect of thallium on the myocardium. The BTC-AM fluorescence assay showed that Tl^+ can be transported via voltage-gated potassium channels, as well as small-conductance and large-conductance calcium-activated potassium channels in mammalian HEK-293 cells and cultured rat muscle cells [36, 37]. Experiments with isolated hepatocytes and PC12 cells indicated that Tl^+ induced apoptosis, decreased intracellular glutathione, and enhanced the production of reactive oxygen species, H_2O_2 , and lipid peroxidation [38, 39]. These deleterious effects of $100 \mu\text{M}$ Tl^+ on hepatocytes were reduced considerably by the MPTP inhibitors (cyclosporine A and carnitine) [39]. The mechanistic basis of thallium's toxicity is the ability of Tl^+ to replace K^+ in K^+ -dependent biochemical processes. It penetrates easily the inner mitochondrial membrane, releases Ca^{2+} from intracellular compartments, and changes cell cycle regulation [1, 12, 14]. In our preliminary experiments, we found that 1 mM Tl^+ exerted a negative inotropic effect on

the spontaneous contraction of frog atrium (Sobol and Korotkov, unpublished data). In this study, we showed for the first time that Ti^+ stimulated the uncontrolled influx of extracellular calcium ions into the cardiomyocytes.

The Ti^+ fluorescence assay showed that Ti^+ is transported into rat heart mitochondria through ATP-sensitive ($\text{mitoK}_{\text{ATP}}$) or BK-type Ca^{2+} activated (mitoK_{Ca}) potassium channels [40, 41]. Ti^+ inhibited the Na^+ -dependent Ca^{2+} efflux from RLM [42]. The swelling of de-energized rat liver mitochondria (RLM) in nitrate media indicated that the inner mitochondrial membrane (IMM) displays low permeability to K^+ but high permeability to Ti^+ [12, 26, 43]. Similar experiments with de-energized RLM in sucrose-adjusted 400 mOsm medium containing a mixture of 0-75 mM TINO_3 with 125 mM nitrates (KNO_3 , NH_4NO_3 , NaNO_3) correspondingly revealed a Ti^+ -induced increase in IMM permeability to K^+ , H^+ , and Na^+ [29]. This increase resulted in additional mitochondrial swelling and decreased state 3 and state 3U_{DNP} respiration. On the contrary, these effects were not found in like experiments with the medium containing 0-75 mM TINO_3 together with 250 mM sucrose instead of 125 mM nitrates. So, these effects of Ti^+ in the experiments with RLM were enhanced in the series with TINO_3 : sucrose < KNO_3 < $\text{NaNO}_3 \leq \text{NH}_4\text{NO}_3$ [29]. The present results with the medium containing NaNO_3 or sucrose (Figs. 4, *a* and 5) and our earlier results [16] with medium containing TINO_3 and nitrates (KNO_3 , NH_4NO_3) revealed a similar series in the experiments with de-energized rat heart mitochondria (RHM). Our experiments with the different mitochondrial preparations (RLM and RHM) therefore showed that the Ti^+ -induced increase in the passive ion permeability of the IMM is manifested by visible mitochondrial swelling and a simultaneous decrease in state 3 and state 3U_{DNP} respiration of these organelles. We have shown previously that quinine inhibited the succinate-induced contraction of RLM, preswollen in medium containing TINO_3 with nitrates [29]. This finding supports the hypothesis that the mitochondrial K^+/H^+ exchanger can catalyze, extruding both Ti^+ [12] and Ti^+ -induced excess of the univalent cations (K^+ , Na^+ , NH_4^+) [43] from the mitochondrial matrix. The succinate-induced contraction of the RHM (Fig. 4, *a*) [16] and RLM [29] can thus be explained also by the participation of the K^+/H^+ exchanger.

The cytotoxic effects of Ti^+ in experiments with isolated rat hepatocytes were significantly reduced in

the presence of CsA and carnitine, which are MPTP inhibitors [39]. The main components of MPTP are believed to be the mitochondrial phosphate carrier (PiC) and cyclophilin D (CyP-D), whereas the adenine nucleotide translocase (ANT) is referred to as its regulatory part [44]. It was earlier found that Ti^+ in sucrose Ca^{2+} free media has not effected on state 3 and state 3U_{DNP} mitochondrial respiration that is in agreement with the finding that Ti^+ does not inhibit respiratory enzymes [9, 28, 43]. In our experiments with Ca^{2+} -loaded RLM, the Ti^+ -induced MPTP opening in medium containing TINO_3 and nitrates (KNO_3 , NaNO_3 , NH_4NO_3) was facilitated by inorganic phosphate [43] but impeded in the presence of both the MPTP inhibitors (ADP, CsA, Mg^{2+}) and the PiC inhibitor mersalyl [15, 45]. This allowed us to reach a conclusion regarding the participation of the ANT and the PiC in the Ti^+ -induced MPTP opening in the inner membrane [21, 45]. We earlier found that a closure of mitochondrial potassium channels ($\text{mitoK}_{\text{ATP}}$ and mitoK_{Ca}) increased the MPTP opening [46]. However, blocking of the mitochondrial Ca^{2+} -uniporter by ruthenium red, Y^{3+} , La^{3+} and Ni^{2+} decreased the MPTP opening [15, 47].

On the other hand, experiments with the Ca^{2+} -loaded RHM showed a decrease in state 3U_{DNP} respiration, the RCR_{DNP} , and $\Delta\Psi_{\text{mito}}$ together with the increased swelling in medium containing TINO_3 as well as KNO_3 and NH_4NO_3 [16] or NaNO_3 (Figs. 4, *b*, 5, 6). As in the case of the Ca^{2+} -loaded RLM [15], these effects were attenuated considerably in the presence of the MPTP inhibitors (ADP, CsA) (Figs. 4, *b*, 5, 6). The detected contraction of the Ca^{2+} -loaded RHM, preswollen in the nitrate media, (Fig. 4, *b*) [16] and also of Ca^{2+} -loaded RLM [15] in presence of ADP and CsA is in agreement with the proposed possible cooperative interaction [48] between these inhibitors and the Ca^{2+} -binding sites of ANT in mammalian mitochondria. The increase in mitochondrial swelling (Fig. 4, *b*) and the decrease in both state 3U_{DNP} respiration and the RCR_{DNP} (Fig. 5, *c*) [16] were visibly eliminated in like experiments with RHM injected into the containing 125 mM NaNO_3 medium with 25 mM TINO_3 replaced by 50 mM sucrose. On the other hand, the even greater decline in state 3U_{DNP} and the RCR_{DNP} in the presence of NEM (Fig. 5, *c* and *d*) is most likely associated with the inhibition of succinate dehydrogenase that we observed earlier in similar experiments with RLM [21]. Above results of these experiments with Ca^{2+} -loaded RHM (Figs. 4, *b*, 5, 6) [16] and

Ca²⁺-loaded RLM [15] suggest that the Ca²⁺ load of mitochondria in medium containing a mixture of TINO₃ with nitrates (KNO₃, NaNO₃, NH₄NO₃) may be reasoned by the opening of CsA-inhibited and ADP-dependent Tl⁺-induced MPTP pores in the inner membrane of these organelles. The decrease of state 4₀ and state 3U_{DNP} respiration is linked to the increased swelling of succinate-energized Ca²⁺-loaded RHM (Figs. 4, b and 5, c) [16] or Ca²⁺-loaded RLM [15]. These results may be associated with a decreased activity of respiratory enzymes due to the deformed spatial structure of the inner membrane, caused by the mitochondrial swelling due to the Tl⁺-induced Na⁺ entry (Fig. 4, a) into the matrix of the Ca²⁺-loaded RHM [15].

In this study, we showed for the first time that Tl⁺ stimulated the uncontrolled influx of extracellular calcium ions into cardiomyocytes. We observed that the inhibition of Ca²⁺ influx with Ca²⁺-free EGTA solution prevented the sustained increase in [Ca²⁺]_i induced by Tl⁺ application. Based on earlier studies and our research, we conclude that more intensive stimulation of the IMM ionic permeability and the Tl⁺-induced MPTP in experiments with RHM, versus RLM, can be explained by the greater sensitivity of muscle tissue, especially heart muscle, but not liver, to intoxication by thallium salts. Furthermore, the more potent toxicity of thallium to RHM can thus help us to find a suitable antidote against thallium poisoning in humans as well. However, Tl⁺-stimulated influx of extracellular calcium into the cardiomyocytes can cause calcium and sodium overload of RHM, which will then lead to the MPTP opening. The latter hypothesis may shed light on the greater sensitivity of heart and striated muscle, than of liver, to thallium intoxication *in vivo*.

Acknowledgments. Authors are grateful to Ms Terttu Kaustia for correcting the English. The research was carried out within the state assignment of FASO of Russia (theme No. AAAA-A18-118012290142-9). Safranin fluorescence was measured using of Research Resource Center equipment for the physiological, biochemical and molecular-biological studies (Sechenov Institute of Evolutionary Physiology and Biochemistry, the Russian Academy of Sciences).

Conflict of interest. No conflicts of interest, financial or otherwise, are declared by the authors.

ВПЛИВ Tl⁺ НА РУХ Ca²⁺ ТА Na⁺ КРІЗЬ НЕОНАТАЛЬНІ КАРДІОМІОЦИТИ І МЕМБРАНИ МІТОХОНДРІЙ СЕРЦЯ ЩУРІВ

С. М. Коротков, В. П. Нестеров,
Г. Б. Білостоцька, І. В. Брайловська,
А. В. Новожилов, К. В. Соболев

Інститут еволюційної фізіології
і біохімії ім. І. М. Сеченова РАН,
Санкт-Петербург, Російська Федерація;
e-mail: korotkov@SK1645.spb.edu

Відомо, що талій спричинює найскладнішу і найсерйознішу токсичну дію, яка уражає важливі органи і тканини людини. Токсична дія на біологічні організми пов'язана, зокрема, зі здатністю Tl⁺ порушувати гомеостаз кальцію і легко проникати крізь внутрішню мембрану мітохондрій (ВММ). Метою цієї роботи було вивчити вплив Tl⁺ на внутрішньоклітинну динаміку Ca²⁺ в неонатальних кардіоміоцитах щурів, а також на проникність натрію крізь ВММ і Tl⁺-індуковане відкриття пори перехідної проникності мітохондрій (ПППМ) в ізольованих Ca²⁺-навантажених мітохондріях серця щурів (МСЩ). Показано, з використанням флуоресцентного кальцієвого індикатора Fura 2AM, що Tl⁺ індукує надходження кальцію крізь плазматичну мембрану і призводить до збільшення кальцію ([Ca²⁺]_i) в цитоплазмі. Це збільшення було ще вираженішим в експериментах із прискоренням трансмембранних потоків Tl⁺ нонактином. Проте, цей ефект припинявся видаленням позаклітинних іонів Ca²⁺, але не інгібувався блокатормом (ніфедипін) кальцієвих каналів. Tl⁺ не вивільняв кальцій із внутрішньоклітинних депо. Tl⁺-потенційована проникність натрію крізь ВММ, через набухання не активованих МСЩ в середовищі, що містить TINO₃ і NaNO₃, посилювалася у разі високої концентрації Tl⁺. Навантаження кальцієм МСЩ індукувало відкриття ПППМ, що супроводжувалося збільшенням набухання, а також зниженням потенціалу внутрішньої мембрани і стану дихання 4₀ (базальний) і 3U_{DNP} (2,4-динітрофенол). Ці ефекти Tl⁺ пригнічувалися інгібіторами ПППМ (циклоспорин А, ADP і *n*-етілмалеїмід). Було показано, що Tl⁺-стимульоване надходження позаклітинного кальцію в кардіоміо-

цяти може спричинити перевантаження МСЦ кальцієм і натрієм, що призводить до відкриття ПППМ, і як, наслідок, до вразливості серцевого м'яза до інтоксикації талієм.

Ключові слова: Tl^+ , Ca^{2+} , Na^+ , кардіоміоцити, мітохондрії серця щурів, пора перехідної проникності мітохондрій (ПППМ).

References

- Mulkey JP, Oehme FW. A review of thallium toxicity. *Vet Hum Toxicol.* 1993; 35(5): 445-453.
- Schoer J. Thallium. In: Hutzinger O (ed) Handbook of Environmental Chemistry. Anthropogenic Compounds. Springer, New York, 1984. P. 143-214.
- Repetto G, del Peso A, Repetto M. Human thallium toxicity. Nriagu JO (ed) Thallium in the environment. John Wiley & Sons Inc, New York, 1998. P. 167-199.
- Hughes MN, Man WK, Whaler BC. The toxicity of thallium(I) to cardiac and skeletal muscle. *Chem Biol Interact.* 1978; 23(1): 85-97.
- Nadel HR. Thallium-201 for oncological imaging in children. *Semin Nucl Med.* 1993; 23(3): 243-254.
- McCall D, Zimmer LJ, Katz AM. Effect of ischemia-related metabolic factors on thallium exchange in cultured rat myocardial cells. *Can J Cardiol.* 1986; 2(3): 176-183.
- Fukumoto M, Kurohara A, Yoshimura N, Yoshida D, Akagi N, Yoshida S. Relationship between ATP synthesis and ^{201}Tl uptake in transformed and non-transformed cell lines. *Nucl Med Commun.* 1998; 19(12): 1169-1175.
- Herman MM, Bensch KG. Light and electron microscopic studies of acute and chronic thallium intoxication in rats. *Toxicol Appl Pharmacol.* 1967; 10(2): 199-222.
- Woods JS, Fowler BA. Alteration of hepatocellular structure and function by thallium chloride: ultrastructural, morphometric, and biochemical studies. *Toxicol Appl Pharmacol.* 1986; 83(2): 218-229.
- Kiliç GA, Kutlu M. Effects of exogenous metallothionein against thallium-induced oxidative stress in rat liver. *Food Chem Toxicol.* 2010; 48(3): 980-987.
- Fukumoto M, Yoshida D, Yoshida S. Subcellular distribution of thallium: morphological and quantitative study in rat myocardium. *Ann Nucl Med.* 1997; 11(4): 291-297.
- Saris NE, Skulskii IA, Savina MV, Glasunov VV. Mechanism of mitochondrial transport of thallos ions. *J Bioenerg Biomembr.* 1981; 13(1-2): 51-59.
- Ichas F, Mazat JP. From calcium signaling to cell death: two conformations for the mitochondrial permeability transition pore. Switching from low- to high-conductance state. *Biochim Biophys Acta.* 1998; 1366(1-2): 33-50.
- Zierold K. Heavy metal cytotoxicity studied by electron probe X-ray microanalysis of cultured rat hepatocytes. *Toxicol In Vitro.* 2000; 14(6): 557-563.
- Korotkov SM, Saris NE. Influence of Tl^+ on mitochondrial permeability transition pore in Ca^{2+} -loaded rat liver mitochondria. *J Bioenerg Biomembr.* 2011; 43(2): 149-162.
- Korotkov SM, Nesterov VP, Brailovskaya IV, Furaev VV, Novozhilov AV. Tl^+ induces both cationic and transition pore permeability in the inner membrane of rat heart mitochondria. *J Bioenerg Biomembr.* 2013; 45(6): 531-539.
- Sobol CV, Korotkov SM, Belostotskaya GB, Nesterov VP. The influence of probiotics and probiotic product on respiration of mitochondria and intracellular calcium signal in cells of cardiovascular system. *Biochemistry (Mosc). Suppl Series A: Membr Cell Biol.* 2013; 7(4): 294-301.
- Panov A, Kubalik N, Zinchenko N, Hemen-dinger R, Dikalov S, Bonkovsky HL. Respiration and ROS production in brain and spinal cord mitochondria of transgenic rats with mutant G93a Cu/Zn-superoxide dismutase gene. *Neurobiol Dis.* 2011; 44(1): 53-62.
- Waldmeier PC, Feldtrauer JJ, Qian T, Lemasters JJ. Inhibition of the mitochondrial permeability transition by the nonimmunosuppressive cyclosporin derivative NIM811. *Mol Pharmacol.* 2002; 62(1): 22-29.
- Korotkov SM, Glazunov VV, Yagodina OV. Increase in the toxic effects of Tl^+ on isolated rat liver mitochondria in the presence of nonactin. *J Biochem Mol Toxicol.* 2007; 21(2): 81-91.
- Korotkov SM, Konovalova SA, Brailovskaya IV, Saris NE. To involvement the conformation of the adenine nucleotide translocase in opening the Tl^+ -induced permeability transition pore in Ca^{2+} -loaded rat liver mitochondria. *Toxicol In Vitro.* 2016; 32: 320-332.

22. Ruzsnyák I, György L, Ormai S, Millner T. On some potassium-like qualities of the thalliumion. *Experientia*. 1968; 24(8): 809-810.
23. Talbot PA. Nature of increase in quantal release by the thallous ion at frog end plates with and without nerve stimulation. *J Gen Physiol*. 1992; 100(5): 881-901.
24. Skulskii IA, Savina MV, Glasunov VV, Saris NE. Electrophoretic transport of Tl^+ in mitochondria. *J Membr Biol*. 1978; 44(2): 187-194.
25. Shier WT, DuBourdiou DJ. Sodium- and calcium-dependent steps in the mechanism of neonatal rat cardiac myocyte killing by ionophores. I. The sodium-carrying ionophore, monensin. *Toxicol Appl Pharmacol*. 1992; 116(1): 38-46.
26. Brierley GP, Jurkowitz M. On the mechanism of energy-dependent contraction of swollen mitochondria. *Biochem Biophys Res Commun*. 1976; 68(1): 82-88.
27. Perrin DD. Stability Constants of Metal-ion Complexes. Part B. Organic Ligands. Pergamon Press, New York, 1979. 1263 p.
28. Melnick RL, Monti LG, Motzkin SM. Uncoupling of mitochondrial oxidative phosphorylation by thallium. *Biochem Biophys Res Commun*. 1976; 69(1): 68-73.
29. Korotkov SM. Effects of Tl^+ on ion permeability, membrane potential and respiration of isolated rat liver mitochondria. *J Bioenerg Biomembr*. 2009; 41(3): 277-287.
30. Fu JD, Yu HM, Wang R, Liang J, Yang HT. Developmental regulation of intracellular calcium transients during cardiomyocyte differentiation of mouse embryonic stem cells. *Acta Pharmacol Sin*. 2006; 27(7): 901-910.
31. Delano ML, Sands H, Gallagher BM. Transport of $^{42}K^+$, $^{201}Tl^+$ and $[^{99m}Tc(dmpe)_2.Cl_2]^+$ by neonatal rat myocyte cultures. *Biochem Pharmacol*. 1985; 34(18): 3377-3380.
32. Peluffo RD, Berlin JR. Electrogenic K^+ transport by the Na^+-K^+ pump in rat cardiac ventricular myocytes. *J Physiol*. 1997; 501(Pt 1): 33-40.
33. Ojcius DM, Zychlinsky A, Zheng LM, Young JD. Ionophore-induced apoptosis: role of DNA fragmentation and calcium fluxes. *Exp Cell Res*. 1991; 197(1): 43-49.
34. Fox J, Ciani S. Experimental and theoretical studies on Tl^+ interactions with the cation-selective channel of the sarcoplasmic reticulum. *J Membr Biol*. 1985; 84(1): 9-23.
35. Korotkov SM, Brailovskaya IV, Kormilitsyn BN, Furaev VV. Tl^+ showed negligible interaction with inner membrane sulfhydryl groups of rat liver mitochondria, but formed complexes with matrix proteins. *J Biochem Mol Toxicol*. 2014; 28(4): 149-156.
36. Weaver CD, Harden D, Dworetzky SI, Robertson B, Knox RJ. A thallium-sensitive, fluorescence-based assay for detecting and characterizing potassium channel modulators in mammalian cells. *J Biomol Screen*. 2004; 9(8): 671-677.
37. Jørgensen S, Johansen TH, Dyhring T. Fluorescence-based Tl^+ -influx assays as a novel approach for characterization of small-conductance Ca^{2+} -activated K^+ channel modulators. *Methods Mol Biol*. 2008; 491: 257-266.
38. Hanzel CE, Verstraeten SV. $Tl(I)$ and $Tl(III)$ activate both mitochondrial and extrinsic pathways of apoptosis in rat pheochromocytoma (PC12) cells. *Toxicol Appl Pharmacol*. 2009; 236(1): 59-70.
39. Pourahmad J, Eskandari MR, Daraei B. A comparison of hepatocyte cytotoxic mechanisms for thallium (I) and thallium (III). *Environ Toxicol*. 2010; 25(5): 456-467.
40. Wojtovich AP, Williams DM, Karcz MK, Lopes CM, Gray DA, Nehrke KW, Brookes PS. A novel mitochondrial K_{ATP} channel assay. *Circ Res*. 2010; 106(7): 1190-1196.
41. Testai L, Martelli A, Marino A, D'Antongiovanni V, Ciregia F, Giusti L, Lucacchini A, Chericoni S, Breschi MC, Calderone V. The activation of mitochondrial BK potassium channels contributes to the protective effects of naringenin against myocardial ischemia/reperfusion injury. *Biochem Pharmacol*. 2013; 85(11): 1634-1643.
42. Nalyvajko NV, Vovkanych LS, Dubitsky LO. Inhibitory analysis of the monovalent metals' cations interaction with the system of Na^+ -dependent Ca^{2+} efflux from the liver mitochondria. *Ukr Biokhim Zhurn*. 2006; 78(5): 44-50. (In Ukrainian).
43. Korotkov SM, Emel'yanova LV, Yagodina OV. Inorganic phosphate stimulates the toxic effects of Tl^+ in rat liver mitochondria. *J Biochem Mol Toxicol*. 2008; 22(3): 148-157.
44. Varanyuwatana P, Halestrap AP. The roles of phosphate and the phosphate carrier in the mitochondrial permeability transition pore. *Mitochondrion*. 2012; 12(1): 120-125.

45. Korotkov SM, Konovalova SA, Nesterov VP, Brailovskaya IV. Mersalyl prevents the TI^+ -induced permeability transition pore opening in the inner membrane of Ca^{2+} -loaded rat liver mitochondria. *Biochem Biophys Res Commun.* 2018; 495(2): 1716-1721.
46. Korotkov SM, Brailovskaya IV, Shumakov AR, Emelyanova LV. Closure of mitochondrial potassium channels favors opening of the TI^+ -induced permeability transition pore in Ca^{2+} -loaded rat liver mitochondria. *J Bioenerg Biomembr.* 2015; 47(3): 243-254.
47. Korotkov S, Konovalova S, Emelyanova L, Brailovskaya I. Y^{3+} , La^{3+} , and some bivalent metals inhibited the opening of the TI^+ -induced permeability transition pore in Ca^{2+} -loaded rat liver mitochondria. *J Inorg Biochem.* 2014; 141: 1-9.
48. Halestrap AP, Brenner C. The adenine nucleotide translocase: a central component of the mitochondrial permeability transition pore and key player in cell death. *Curr Med Chem.* 2003; 10(16): 1507-1525.