

S. Franz, D. Perego, O. Marchese, M. Bestetti

**PHOTOELECTROCHEMICAL ADVANCED OXIDATION
PROCESSES ON NANOSTRUCTURED TiO₂ CATALYSTS:
DECOLORIZATION OF A TEXTILE AZO-DYE**

Department of Chemistry, Materials and Chemical Engineering "G. Natta" –
Politecnico di Milano, Italy
silvia.franz@polimi.it

This work describes a novel approach for water treatment by photoelectrocatalysis, based on nanostructured TiO₂. The decolorization of aqueous solutions containing the azo-dye RR243 is carried out in a tubular photocatalytic reactor working in semi-batch mode under electrical polarization of the catalyst. Two different nanostructured catalysts were tested: nanotubular TiO₂ obtained by conventional anodization (CA), and a novel photoactive nanoporous TiO₂ obtained by plasma electrolytic oxidation (PEO). Neither UV irradiation of the TiO₂ catalysts nor the electrical bias individually considered lead to a significant reduction of the dye concentration. By irradiating the catalysts with UVC light while applying an electrical bias to the same, the concentration of the dye decreased from 25 mg/L to 2,5 mg/L using the nanotubular CA TiO₂ catalyst, and to less than 1,8 mg/L using the novel nanoporous PEO TiO₂ in 50 min. The main advantages of this method over current approaches for the degradation of pollutants are both the considerable processing time reduction and a suitable and easy-to-scale-up reactor design. A further advantage is the relatively easyness in the production of the TiO₂ catalysts by PEO.

Keywords: anodization, decolorization, advanced oxidation processes, photoelectrochemistry, titanium dioxide, water treatment

Introduction

In compliance with the strict regulations on water quality, in recent years the processes for water and wastewater treatments were mostly conceived to address the removal of refractory organic compounds, such as dyes, solvents or pesticides. Chemical oxidation treatments involving transient radical species,

© S. Franz, D. Perego, O. Marchese, M. Bestetti, 2015

also referred to as Advanced Oxidation Processes (AOPs), are among the most investigated methods for the removal of recalcitrant organics [1]. An alternative approach to conventional chemical generation of radicals is the heterogeneous photochemical catalysis based on the use of titanium dioxide [2, 3]. Titanium dioxide is a wide band gap (rutile 3,0 eV, anatase 3,2 eV) semiconductor which in the presence of water or air produces highly reactive radicals when irradiated with UV light ($\lambda < 380$ nm). The photoactivity of the titanium dioxide is extremely dependent on the level of crystallinity and on the crystalline phase composition, where anatase is the required crystal phase. In photoelectrochemical AOPs two main issues should be addressed: the form (dispersed powder, supported powder, film etc.) and the efficiency of the catalyst and the engineering of the whole process.

Heterogeneous photochemical catalysis has recently found application in AOPs, where the titanium dioxide catalyst is used in the form of dispersed nanopowders in aqueous solutions [4, 5]. The main disadvantage of this approach is that a separation treatment is required after use. The immobilization of TiO₂ nanopowders deposited by sol-gel technique onto metallic wire meshes [6] and the development of nanotubular TiO₂ films obtained by electrochemical anodization [7] overcome this problem, and open new perspectives in the field. In fact, supported nanostructured titanium dioxide can be used as electrode, and studies available in literature explain the potentialities of this class of AOPs [8, 9].

Several studies reported in literature describe the preparation of nanotubular TiO₂ films by anodic oxidation of titanium substrates. Nanostructured titanium dioxide coatings can also be obtained by Plasma Electrolytic Oxidation (PEO), which involves anodization at potentials above the breakdown voltage of the coating. After the pioneering works done more than one century ago by Russian researchers and in 30's by German researchers on high voltage electrolysis, it was only in the 70's that Markov and Markova demonstrated the feasibility of using PEO process for the production of ceramic coatings on light metal alloys [10]. In principle, the PEO process could be an extremely effective route to obtain photoactive titanium dioxide coatings, with the additional possibility of modifying the photoactivity of the coating by doping [11]. However, as a matter of fact, the studies available in literature mainly report difficulties in controlling the crystalline phase composition, which strongly affects the photoactive properties [12, 13]. Indeed, to the authors knowledge there are very few investigations on TiO₂ obtained by PEO due to poor photocatalytic properties of the resulting coatings. Furthermore, there is an issue concerning

the scalability of this process because of the extremely high currents flowing during the initial stages of the anodic oxidation process.

In the present study, the decolorization of an organic recalcitrant azo-dye of use in the textile industry was carried out in a laboratory reactor working in semi-batch model. The UV activation of the catalysts was coupled to the electrochemical activation of the same by supporting the TiO_2 catalysts on polarizable titanium meshes. Two different photoactive TiO_2 catalysts were employed, having a self-organized nanotubular morphology obtained by conventional anodization or a novel porous structure obtained by PEO. In the present investigation, it is demonstrated that nanoporous TiO_2 catalysts obtained by PEO shows faster degradation kinetics than self-organized nanotubular TiO_2 . The photoelectrochemical reactor described in the present paper allowed 90% decolorization of the azo-dye RR243 in less than 50 min of processing time. Furthermore, the integration of an innovative photoactive electrode obtained by PEO lead to an easier industrialization of the whole process, contributing to make a significant step forward in the development of electrophotocatalytic processes for water decontamination.

Experimental

Preparation of the nanostructured TiO_2 catalysts. Nanoporous titanium dioxide samples were obtained by PEO of Grade 1 titanium tubular wire meshes (exposed area 540 cm^2 , supplied by Tessitura Tele Metalliche Rossi Srl). The nanoporous TiO_2 coatings were obtained in a two electrodes cell where the couterelectrode was a titanium alloy mesh. The electrolyte consisted of $0,5 \text{ M H}_2\text{SO}_4$ maintained at $-3,5^\circ\text{C}$ for the whole duration of the oxidation treatment by means of a cryostat (HAAK D10). The PEO was carried out at the constant cell voltage of 160 V for 20 min . After oxidation, the titanium dioxide films were rinsed in distilled water and dried in nitrogen flow. No thermal pre- and post-treatments were carried out on PEO TiO_2 . The average thickness of the resulting titanium dioxide films was $1 \mu\text{m}$. The average porosity was 5% as evaluated by means of ImageJ software analysis of SEM surface micrographs.

The properties of the TiO_2 coatings obtained by low temperature PEO were compared with those of nanotubular titanium dioxide films obtained by conventional anodization (CA) of titanium sheets (2 cm^2) and wire meshes (540 cm^2) of Grade 1 commercial purity titanium. In both cases, the nanotubular titanium dioxide coatings were obtained by anodization in $1 \text{ M H}_2\text{SO}_4$ and $78,5 \text{ mM HF}$ at 20 V and room temperature for 24 h . A two electrode cell

was used, where the counterelectrode consisted of graphite bars. Annealing pre- and post-treatments at 400°C for 2 h in air were required to obtain the nanotubular morphology and a photoactive crystalline phase composition. The nanotubular titanium dioxide coating had an approximate thickness of about 500 nm, pore size of 150 nm and pore spacing of 150 nm.

Morphological, structural and photoelectrochemical characterization of the TiO₂ catalysts. The surface morphology was investigated by means of Scanning Electron Microscopy (SEM – Zeiss® EVO 50) equipped with LaB₆ source, operated at 20 kV accelerating voltage. The crystallographic structure of the titanium dioxide coatings was assessed by X-ray diffraction (XRD) using a Philips PW1830 instrument, with Cu K_{α1} radiation and Bragg-Brentano geometry. XRD was performed in the 2θ angular range of 30 – 90°.

An estimation of the grain size can be calculated according to Scherrer equation. The weight fraction of anatase f_A (%) was calculated according to [14], where I_{R110} and I_{R101} are the intensity of the XRD reflection peaks of (110) rutile at 2θ ~ 27,45° and of the (101) anatase at 2θ ~ 25,30°:

$$f_A = \frac{1}{(1 + 1,26 \frac{I_{R110}}{I_{A101}})} \cdot 100 \quad (1)$$

Porosity was evaluated by means of ImageJ analysis of SEM surface micrographs.

The photoelectrochemical properties of the titanium dioxide coatings were assessed by linear sweep voltammetry in a three electrodes cell. The working electrode was the nanoporous titanium dioxide disc obtained either by PEO or by conventional anodization. An Ag/AgCl electrode (3 M KCl + 0,210 vs. NHE) was taken as reference and the counterelectrode was a an activated titanium mesh. The cell volume was 6 l. The electrolyte consisted of a 4,2 mM KCl solution prepared by dissolving weighted salt into distilled water. The effect of irradiation on electrical properties of the titanium dioxide coatings was evaluated in terms of photocurrent, i.e. difference between the current response with and without irradiation, as a function of the polarization potential. For measurements, a potentiostat/galvanostat (Solartron Analytical ModuLab ECS) was used. The irradiation was achieved by means of a monochromatic UV commercial lamp (Helios Italquartz) emitting at 254 nm and having a nominal power of 30 W. The irradiance on the titanium dioxide catalyst in the

selected cell configuration was about 8 W/m^2 as measured by quantum-photo-radiometer (HD 9021, Deltaohm) having a detector with a spectral response in the wavelength range $100 - 280 \text{ nm}$.

Electrophotocatalytic decolorization experiments. For the decolorization experiments, the azo-dye Drimaren Red 243 X-6BN (RR243) was selected as target molecule, whose molecular structure is shown in Fig. 1. Aqueous solutions containing 25 mg/L RR243 and $4,2 \text{ mM}$ KCl were used. The volume treated in each decolorization experiment was 2 l .

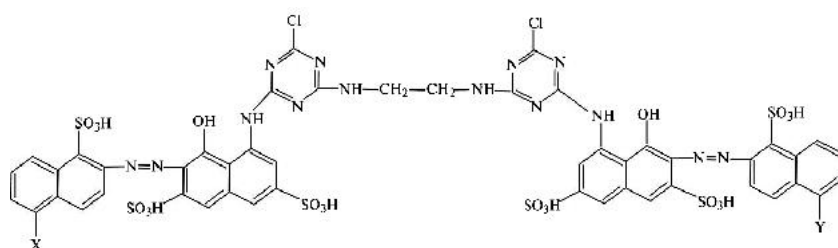

Fig. 1. Molecular structure of Drimaren Red 243 X-6BN.

The decolorization experiments were carried out by using a laboratory scale reactor operating in semi-batch mode (Fig. 2). The reactor consisted of polymethylmethacrylate tube with a bottom water inlet and an upper outlet, containing a UV source surrounded by the titanium dioxide mesh (anode), and a steel mesh working as counter electrode (cathode). The photoactive anodes consisted of a titanium tubular wire mesh anodized either by PEO or by conventional anodization. The photoelectrodes had same weave and warp. The irradiation was achieved by means of a UV commercial lamp (Helios Italquartz) emitting at 254 nm and absorbing a nominal power of 30 W . The measured irradiance on the titanium dioxide catalyst was about 8 W/m^2 . During the decolorization experiments, a constant cell voltage in the range $1,5-3,5 \text{ V}$ was applied by means of a potentiostat/galvanostat (AMEL 2549). The flow rate was kept constant at the value of 700 l/h . The annular cross-section area was 9 cm^2 . During the decolorization experiments, sampling (5 ml) was carried out every five minutes, and the concentration of RR243 was followed by UV-Vis spectrophotometric measurements (HP 8453).

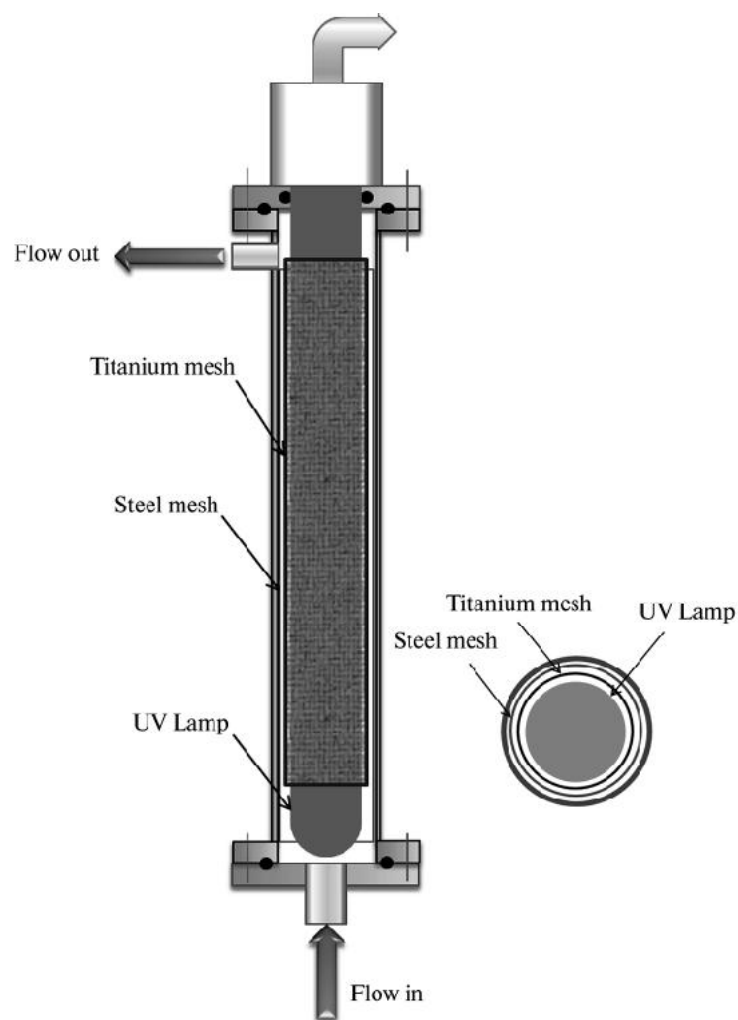

Fig. 2. Scheme of the laboratory scale electrochemical photoreactor working in semi-batch mode.

Results and discussion

Structural, morphological and photoelectrochemical characterization of the TiO₂ catalysts. Surface micrographs of nanoporous TiO₂ catalysts obtained by PEO are showed in Fig. 3, a, and the corresponding fracture cross-section micrograph is reported in the inset.

The average porosity of the coatings is about 3%, the pores have an average diameter of 110 nm and appear to be preferentially oriented perpendicular to the Ti substrate. The TiO₂ coatings had an average thickness of about 1,1 μm and showed good adhesion to the substrate. In Fig. 3, b, the top surface and

cross section SEM micrographs of TiO_2 coatings obtained by CA are shown. The TiO_2 coatings obtained by CA show a typical self-organized nanotubular morphology, the average diameter of the tubes being around 80 nm and the thickness being around 500 nm.

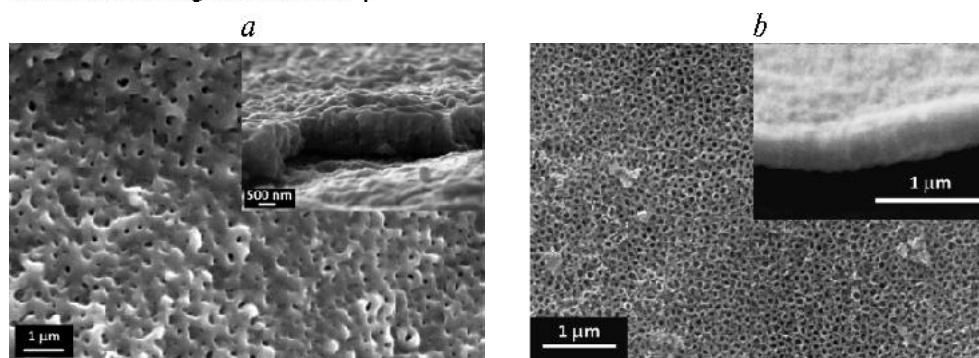

Fig. 3. SEM micrographs of: a – nanoporous TiO_2 coatings obtained by PEO; b – nanotubular TiO_2 coatings obtained by conventional anodization.

In Fig. 4, *a* the XRD patterns of the same TiO_2 coatings are showed. Both coatings consist of a mixture of anatase and rutile allotropic phases. Based on the XRD patterns, the average phase composition of the coating can be calculated using Eq. 1. Nanotubular titanium dioxide coatings obtained by CA followed by annealing contain about 84% of anatase, the remaining fraction being rutile. TiO_2 coatings obtained by PEO without annealing post-treatments show higher anatase fraction (about 93%), with only a small amount of rutile (7%). In both cases, the average crystallite sizes of the TiO_2 coatings were evaluated on the basis of the XRD diffraction pattern according to Sherrer, and it was in the range 23 – 26 nm for both anatase and rutile phases.

The photoactivity of the titanium dioxide coatings was evaluated by measuring the current response of the TiO_2 electrode under UV irradiation as a function of anodic polarization. Current measurements were carried out at various potentials values, in the range 0,2÷2,0 V (vs. Ag/AgCl). The current response of the unirradiated photoanodes was subtracted to the current circulating under UV irradiation. The resulting current density, often referred to as photocurrent density, can be taken as indicator of the degree of photoactivation of the catalyst. In Fig. 4, *b* the photocurrent density of TiO_2 catalysts obtained by PEO and CA are showed. Experiments were repeated three times. The photoelectrochemical response of the TiO_2 anodes depends on the applied voltage.

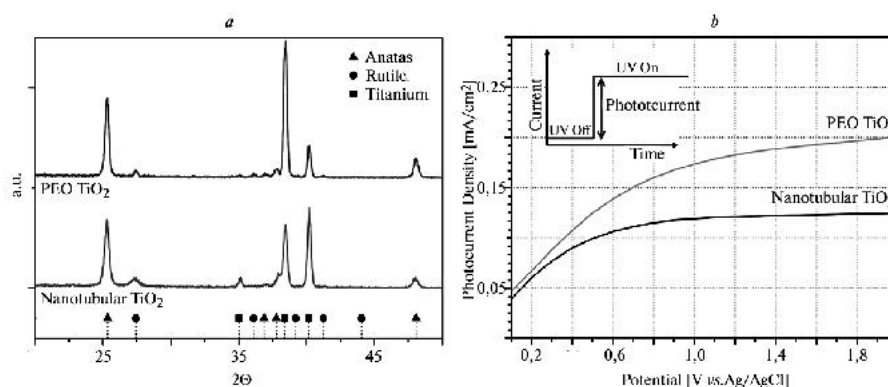

Fig. 4. XRD patterns of nanoporous TiO_2 coatings obtained by PEO and of nanotubular TiO_2 coatings (a); photocurrent density of nanoporous TiO_2 coatings obtained by PEO and of nanotubular TiO_2 coatings obtained by CA as a function of the polarization potential (b).

The photocurrent of TiO_2 coatings obtained by CA linearly increased at lower bias values (below 1V vs. Ag/AgCl), reaching a steady value of about 0,120 mA/cm² at higher potential values. TiO_2 coatings obtained by PEO showed a significantly higher photocurrent response, about 0,200 mA/cm² at 2V, and a slight increase with the applied voltage in the whole considered range.

Photoelectrocatalytic decolorization of an azo-dye solution on nanoporous TiO_2 catalysts. Decolorization of the azo-dye RR243 solutions was carried out in the reactor in Fig. 2, where the photocatalytic electrode was a titanium dioxide wire mesh obtained by PEO at 160 V and $-3,5^\circ\text{C}$ for 20 min. The decolorization of the same dye was also carried out using as a photoactive electrode a nanotubular titanium dioxide wire mesh obtained by conventional anodization (NT). An external bias of 1,5V was applied during the decolorization experiment. The effectiveness of the decolorization process was assessed by measuring the concentration of the azo-dye as a function of time, and it is represented as the ratio between the actual concentration (C) and the initial concentration (C_0) of the dye as a function of processing time. The decolorization curves are showed in Fig. 5. Each decolorization experiment was repeated three times. It was already demonstrated [9] that the TiO_2 catalysts, whether polarized or not, do not significantly reduce the concentration of the dye, the only active processes being the electrochemical reactions and adsorption of the dye on the catalysts surface, respectively. UV irradiation without the use of catalysts led to a degradation of about 6% of the initial dye concentration after 60 min. The sole polarization of the TiO_2 catalyst at 1,5 V, without UV irradiation, lead to

similar results, as the concentration of the dye decreased of about 30 % within the same processing time. The introduction of the nanotubular TiO₂ catalysts and the application of an electrical bias significantly improved the degradation results, leading to a decrease of the dye concentration from 25 mg/L to 2,5 mg/L after 60 min (degradation of 89,6 ± 2,7%). The use of nanoporous TiO₂ catalysts polarized at the same voltage lead to a slightly faster kinetics, since after a 60 min of processing the concentration of the RR243 dye decreased from 25 to 1,7 mg/L.

Heterogeneous catalytic reaction kinetics are often described by the Langmuir – Hinshelwood model, where it is assumed that the surface of the catalyst is energetically uniform, with no interaction between the adsorbed species. The differential form of the Langmuir – Hinshelwood kinetic [15] is:

$$\frac{dC}{dt} = -K_{LH} \frac{K_A C}{1 + K_A C} \quad (2)$$

When $K_A C \ll 1$, Langmuir – Hinshelwood model reduces to a first order kinetics:

$$\frac{dC}{dt} = -K_{LH} K_A C = -k_1 C ; \quad (3)$$

$$C = C_0 \exp(-k_1 t) . \quad (4)$$

The first order kinetic model was applied to the experimental data showed in Fig. 5. The fitting method of least squares was used to calculate the first order kinetic constants (k_1) both for titanium dioxide meshes obtained by conventional anodization and by low temperature PEO. The calculated values for k_1 are reported in Table .

The kinetic constants of conventionally anodized and low-temperature plasma anodized titanium meshes are 0,039 and 0,047 min⁻¹, respectively. The values of the kinetic constants not only show that the two materials are comparable in terms of photocatalytic efficiency, but also that PEO leads to a faster degradation rate than conventional anodization processes. These results are in agreement with Dutta [16] and Rizzo [17], where the Langmuir–Hinshelwood is suggested as the best fitting model for dyes decolorization and aqueous solution degradation by photocatalytic processes.

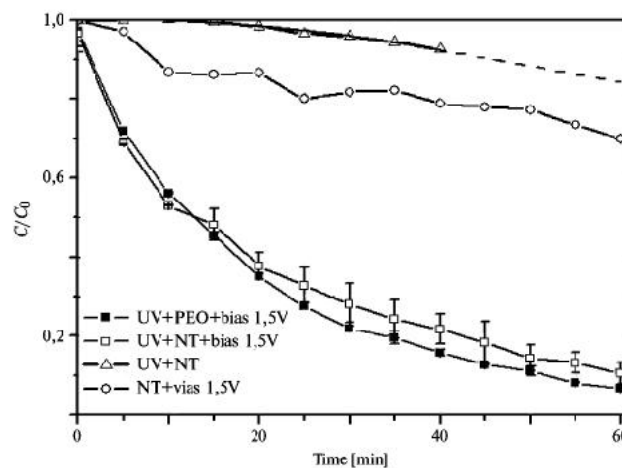

Fig. 5. Photoelectrochemical decolorization curves using NT TiO₂ thin films (empty symbols) and NP TiO₂ (full squares).

Calculated kinetic constants (k) and corresponding coefficient of determination (R^2) for decolorization of RR243 with titanium dioxide meshes obtained by conventional anodization and by low-temperature PEO

Statistical parameters	Nanotubular TiO ₂	Nanoporous TiO ₂
k_1 (min ⁻¹)	0,03893	0,04723
R^2	0,96205	0,99251
Std,Err,	0,00155	0,00108
χ^2	0,00233	0,00054
p-value	1,56710 ⁻¹¹	8,10510 ⁻¹⁵
n	39	26

Decolorization times reported in this study for significant dye removal were one order of magnitude lower than results previously reported in literature. Indeed, literature reports several examples of processes based on TiO₂ catalyst, mainly prepared by CA, where target molecules (for example Methylene blue or Rhodamine-B) are not of industrial interest and processing times for significant removal are much longer [18 – 20]. Considering the high reaction rates of the radicals involved in TiO₂-based photocatalysis [21, 22], the long reaction times could be mainly attributed to unoptimized reactor configuration. The issue of the optimization of reactor configuration has been addressed in the present paper, the main outcome being the reduced times for dye removal with respect to data reported in literature.

Furthermore, the photocatalytic process described in the present paper occurs onto supported catalysts, solving the issue of post-processing disposal affecting heterogeneous photocatalysis onto dispersed catalysts.

Additional advantages of the proposed approach concern the process for catalysts production. The production of TiO_2 coatings by conventional anodization shows three main drawbacks: the titanium substrate usually requires a thermal pre-treatment to release internal stresses, which would hinder the formation of the nanotubular structure; the conventional anodization in sulfuric and hydrofluoric acid aqueous solutions must be carried on for at least 20 h leading to a nanotubular morphology having an amorphous structure, which is not photoactive; finally, thermal post-treatments are needed to convert the amorphous structure into anatase-rich crystals. On the other hand, PEO processing does not require thermal pre- and post-treatments to produce photoactive TiO_2 coatings, and the processing times are reduced by two orders of magnitude with respect to CA. These can be considered significant technological advantages over current techniques to produce photoactive titanium dioxide coatings by conventional anodization.

Conclusions

Water treatment was addressed with a novel approach, consisting in photoelectrocatalysis on nanostructured TiO_2 thin films of new conception and an appropriate reactor design. Two TiO_2 -based catalyst were tested: a nanotubular titanium dioxide coating obtained by conventional anodization and requiring annealing pre- and post-treatments, and a novel nanoporous titanium dioxide film obtained by low temperature plasma electrolytic oxidation. As model compound it was used the textile azo-dye Drimaren Red 243 X-6BN (RR243). The decolorization of the dye was carried out in a laboratory-scale reactor working in a semi batch mode where the TiO_2 catalysts were supported on titanium meshes. During the decolorization, the titanium dioxide coatings were irradiated with a 30 W monochromatic UV source emitting at 254 nm and were polarized at 1,5 V. Decolorization experiments carried out for 60 min reduced the initial concentration of the dye of more than 93%, the fastest kinetic rate constant being measured using TiO_2 thin films obtained by low temperature PEO.

The approach adopted in the present paper entails some technological advantages over previous results. The optimization of the reactor design reduced the times required for decolorization by one order of magnitude with

respectet to data reported in literature, making the electrophotocatalytic water treatment more competitive with stablished advanced oxidation processes. The production of TiO₂ catalysis by low temperature plasma electrolytic oxidation did not need annealing treatments nor long processing times, as in the case of conventional anodization, leading to significant advantages.

Acknowledgments

The authors would like to acknowledge Alessandro De Gasperin for his contribution in the decolorization experiments. This study was supported by Regione Lombardia (project no. 13726167),

References

- [1] *Parsons S.* Advanced oxidation processes for water and wasterwater treatment. – London: IWA Publishing, 2004.
- [2] *Hashimoto K., Irie H., Fujishima A.* //Jap. J. Appl. Phys. – 2005. – **44**. – P. 8269 – 8285.
- [3] *Hoffmann M. R., Martin S. T., Choi W., Bahnemann D. W.* // Chem. Rev. – 1995. – **95**. – P. 69 – 96.
- [4] *Sanchez M., J. Riviero M., Ortiz I.* // Desalination. – 2010. – **262**. – P. 141 – 146.
- [5] *Choi H., Al-Abed S.R., Dionysiou D.D., Stathatos E., Lianos P.* //Sustainable water for the future: water recycling versus desalination /Eds. I.C. Escobar, A.I. Schafer. – Amsterdam: Elsevier, 2010. – P. 229–254.
- [6] *Bestetti M., Sacco D., Brunella F., Franz S., Amadelli R., Samiolo L.* //Mater. Chem. Phys. – 2010. – **124**. – P. 1225 – 1231.
- [7] *Bestetti M., Franz S., Cuzzolin M., Arosio P., Cavallotti P. L.* //Thin Solid Films. – 2007. – **515**. – P. 5253 – 5258.
- [8] *Bestetti M., Franz S., Brunella F.* Politecnico di Milano, "Metal or metalized fabrics coated with nanostructured titanium dioxide", WO WO 2008001405 A2, 20.03.2008.
- [9] *Turolla A., Fumagalli M., Bestetti M., Antonelli M.* //Desalination. – 2012. – **285**. – P. 377 – 382.
- [10] *Yerokhin A.L., Nie X., Leyland A., Matthews A., Dowe S.J.* //Surf. Coat. Technol. – 1999. – **122**. – N 2/3. – P. 73 – 93.
- [11] *Xiaohong W., Qin W., Jiang Z.* //Thin Solid Films. – 2006. – **496**. – P. 288 – 292.

- [12] *Poznyak S.K., Talapin D.V., Kulak A.I.* //J. Electroanal. Chem. – 2005. – **579**. – P. 299 – 310.
- [13] *Khan R.H.U., Yerokhin A.L., Matthews A.* //Philos. Mag. – 2008. – **88**. – P. 795 – 807.
- [14] *Spurr R. A., Myers H.* //Anal. Chem. – 1957. – **29**. – P. 760 – 762.
- [15] *Fujishima A., Zhang X., Tryk D. A.*//Surf. Sci. Rep. – 2008. – **63**.– P. 515 – 582.
- [16] *Dutta S., Parsons S., Bhattacharjee C., Jarvis P., Bandyopadhyay S.* //Chem. Eng. J. – 2009. – **155**. – P. 674 – 679.
- [17] *Rizzo L., MERIC S., Guida M., Kassinos D., Belgiorno V.* //Water Res. – 2009. – **43**. – P. 4070 – 4078.
- [18] *Awitor K.O., Rafiqah S., Geranton G., Sibaud Y., Larson P.R., P. Bokalawela R.S., Jernigen J.D., Johnson M.B.* //J. Photochem. Photobiol., A. – 2008. – **199**. – P. 250 – 254.
- [19] *Shin Y.K., Chae W.S., Song Y.W., Sung Y.M.* //Electrochem. Commun. – 2006. – **8**. – P. 465 – 470.
- [20] *Mirelman L.K., Curran J.A., Clyne T.W.* //Surface and Coatings Technol. – 2012. – **207**. – P. 66 – 71.
- [21] *Carp O., Huisman C.L., Reller A.* //Prog. Solid State Chem. – 2004. – **32**. – P. 33–177.
- [22] *Malato S., Ibanez P.F., Maldonado M.I., Blanco J., Gernjak W.* //Catal. Today. – 2009. – **147**. – P. 1 – 59.

Received 13.06.2014