

ДОСЛІДЖЕННЯ ТА ОПТИМІЗАЦІЯ ТЕХНОЛОГІЧНИХ ОБ'ЄКТІВ І СИСТЕМ ЕНЕРГЕТИКИ

UDC: 621.311.661

M.M. KULYK, Member of the National Academy of Sciences of Ukraine, **V.D. BILODID**,
Candidate of Science (Eng.), Institute of General Energy, National Academy of Sciences
of Ukraine, Kyiv

OPERATIVE CONDITIONS AND ATTAINABLE VOLUMES OF USING HEAT PUMPS AT HEAT AND POWER PLANTS IN THE INTEGRATED POWER SYSTEM OF UKRAINE

We investigate two variants of the operative conditions of heat and power plants with technological schemes where heat pumps are used for utilizing the heat of exhaust gases of steam generators: the variant with controlled electric power of heat and power plant and economical variant ensuring the maximum cost effectiveness. It is demonstrated that the variant with controlled electric power is reasonable only if the electric power of heat and power plant is used for eliminating system problems, in particular, for controlling power generation in response to the electric load demands, with the corresponding payments for these services. The economical variant is much more cost effective because it provides a substantial increase in the output thermal power of the heat and power plant. An additional substantial economic effect can be obtained in the case when the heat and power plant, working according to the economical variant, is involved to a system of the automatic control of frequency and power as a part of the integrated power system.

Key words: heat and power plant, heat pump, capacity, heat, electric power, balance, efficiency.

The last decade is characterized by the fact that the world community relies, to an increasing degree, upon energy supplied from renewable energy sources. In this case, special consideration is given, without sufficient arguments, to wind and solar energy, although these renewable energy sources at present cannot compete with the traditional technologies of the production of electric and heat energy. For strange reasons, both manufacturers and managers of all levels in Ukraine do not consider the possibility to use heat-pump technologies, allowing the utilization of heat from various low-grade heat sources. This fact disagrees with the opinions of numerous scientists who have proved that such technologies are highly competitive. Special attention should be given to publications

with the results of studies of low-grade heat utilization systems based on heat pumps. These systems use waste heat from various industrial heat sources (exhaust gases of steam generators, process liquids in cooling systems, etc.), specifically at power-generating plants and, first of all, at heat and power plants (HPP). One of the promising variants of using heat pumps in the technological schemes of HPP [1, 2] is illustrated in Figure.

In this paper, we analyze the possible operative conditions and efficiency of such systems. The use of heat pumps for utilizing the waste heat of exhaust gases of steam generators is reasonably practicable because such utilization enables one to increase the fuel utilization factor.

The thermal power Q_v that is lost with exhaust gases of steam generators shown in Figure is determined as follows:

© M.M. KULYK, V.D. BILODID, 2014

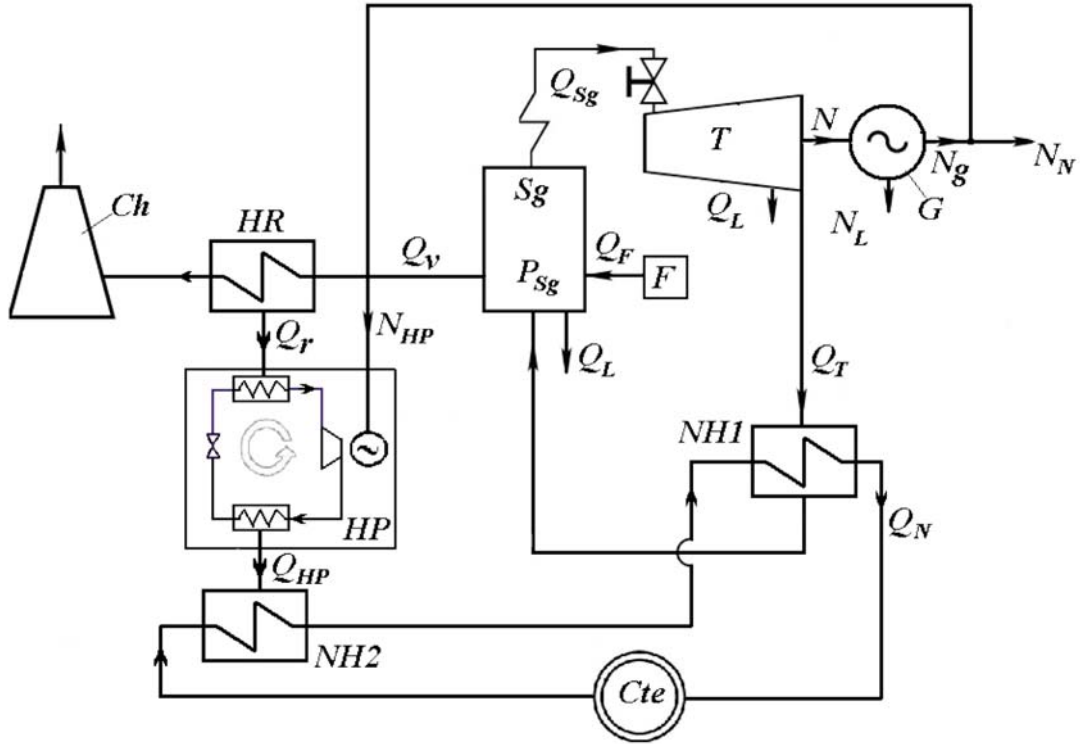

Schematic diagram illustrating the utilization of the heat of exhaust gases of steam generators of HPP with using heat pumps:

Ch – chimney; Sg – steam generator; T – turbine; Cte – consumers of thermal power; HR – waste heat recovery units; HP – heat pumps; G – electric generators; $NH1, NH2$ – heaters of delivery water

$$Q_v = \eta_v P_{Sg} \tag{1}$$

where P_{Sg} is the capacity of the steam generator, and η_v is the part of its capacity that is lost with exhaust gases.

From the exhaust gases, the waste heat recovery unit extracts thermal power which is given by

$$Q_r = \eta_r Q_v, \tag{2}$$

where η_r is the utilized part of thermal power of the exhaust gases.

The heat pump, using the part N_{HP} of output power of the electric generator, transfers the extracted thermal power Q_r with the required parameters to thermal power consumers. In this case, the operation of the heat pump is characterized by the following relations [3, 4]:

$$Q_{HP} = \varphi N_{HP}, \tag{3}$$

and

$$Q_{HP} = \frac{\varphi}{\varphi - 1} Q_r, \tag{4}$$

where Q_{HP} is the output thermal power of the heat pump, and φ is the coefficient of heat-pump performance.

The output thermal power of the heat pump is transferred to the heating system via heaters NH1 and NH2, i.e., an additional thermal power Q_{HP} is generated. Since the coefficient of heat-pump performance for modern heat pumps reaches 4.5 ... 6 or even more, the technological scheme illustrated in Figure under certain conditions can be cost-justifiable.

There are two variants of the operative conditions of HPP with the technological scheme illustrated in Figure where heat pumps are used.

**Variant 1
(variant with controlled electric power)**

According to this variant (it is considered in [2]), thermal power Q_N at the output of the heater NH1 is transferred to the heating system and maintained at such level as it would be if there is no heat pump in the technological scheme of the HPP, that is:

$$Q_N = Q_o, \tag{5}$$

$$Q_o = \frac{N_o}{K}, \tag{6}$$

where N_o is the rated electric capacity of the turbine, and K is the specific production of electric power in operation of the turbine as a thermal power source [5].

When analyzing Variant 1, the operative conditions of the HPP are determined by solving the system of algebraic equations that describe certain elements of its technological scheme.

For the heater (NH1):

$$Q_T + Q_{HP} = Q_o = Q_N, \quad (7)$$

where Q_T is the output thermal power of the turbine, Q_{HP} is the output thermal power of the heat pump, and Q_N is the thermal power transferred to the heating system.

For the turbine (T):

$$\eta_T Q_{Sg} - Q_T - N = 0, \quad (8)$$

$$Q_{Sg} = \eta_{Sg} P_{Sg}, \quad (9)$$

where η_T is the turbine efficiency factor, Q_{Sg} is the output power of the steam generator, η_{Sg} is its efficiency factor, and N is the part of output power of the turbine which is transferred to the electric generator.

For the electric generator (G):

$$N_G - N_N - N_{HP} = 0, \quad (10)$$

$$N_G = \eta_G N, \quad (11)$$

where N_G is the output power of the generator, η_G is its efficiency factor, N_N is the electric power transferred to the power network, and N_{HP} is the part of output power of the generator which is used for operating the heat pump.

For the system of equations (7), (8), and (10), taking into account equations (1) ... (6) and (9), it is possible to find analytical solutions. Since the parameters Q_T and N in (8) are related according to formula (6), the output thermal power Q_T of the turbine is given by

$$Q_T = \frac{\eta_T}{1+K} Q_{Sg}, \quad (12)$$

From equations (1) ... (4) and (9), it follows that

$$Q_{HP} = \frac{\eta_v \eta_r \varphi}{\eta_{Sg} (\varphi - 1)} Q_{Sg}. \quad (13)$$

Substituting (13) in (7), we determine the output thermal power Q_{Sg} of the steam generator as

$$Q_{Sg} = \frac{Q_o}{a}, \quad (14)$$

where the coefficient a depends only on the output parameters:

$$a = \frac{\eta_T}{1+K} + \frac{\eta_v \eta_r \varphi}{\eta_{Sg} (\varphi - 1)}, \quad (15)$$

Since the quantity Q_o is also known, the output thermal power Q_{Sg} of the steam generator is determined. All the other parameters of the technological scheme illustrated in Figure can be expressed in terms of the thermal power Q_{Sg} by analogy with (12) and (13). Specifically, the part of output power of the turbine which is transferred to the electric generator is equal to

$$N = \frac{K \eta_T}{1+K} Q_{Sg}, \quad (16)$$

the electric power consumed by the heat pump is

$$N_{HP} = \frac{\eta_v \eta_r}{\eta_{Sg} (\varphi - 1)} Q_{Sg}, \quad (17)$$

the output power of the electric generator is equal to

$$N_G = \frac{\eta_G K \eta_T}{1+K} Q_{Sg}, \quad (18)$$

the electric power transferred to the power network can be calculated as

$$N_N = \left(\frac{\eta_G K \eta_T}{1+K} - \frac{\eta_v \eta_r}{\eta_{Sg} (\varphi - 1)} \right) Q_{Sg}. \quad (19)$$

System of equations (12) ... (19) enables one to calculate the operative conditions of technological scheme of the equivalent HPP illustrated in Figure. Table 1 contains the results of calculations of the operative conditions of HPP in the Integrated Power System of Ukraine according to Variant 1 (the variant with controlled electric power of the HPP). These plants are divided into four groups by initial steam pressure, as is made in [2], for the possibility to compare the results obtained. In these calculations, for all groups of heat and power plants, the initial values of the design parameters are specified as follows: $\eta_r = 0.8$, $\varphi = 4.5$, $\eta_T = 0.78$, and $\eta_G = 0.98$. The other necessary initial parameters are presented in Table 1.

Table 1 - Operative conditions and attainable volumes of using heat pumps at HPP in the Integrated Power System of Ukraine (the variant with controlled electric power)

Parameter identifier	Parameters	Parameter values				Total
-	Initial steam pressure (MPa)	3.4	8.8	12.8	23.5	-
N_i	Installed electric power (MW)	795	1,266	1,880	1,250	5,191
N_o	Rated operating electric power (MW)	636.0	1,012.8	1,504	1,000	4,152.8
Q_i	Installed thermal power (MW) *	3,004.5	2,748.6	3,487.9	1,796.5	11,037.5
Q_o	Rated operating thermal power (MW)	2,403.6	2,198.9	2,790.3	1,437.2	8,830
K	Specific production of electric power in operation of the turbine as a thermal power source (MW (el.) to MW (th.) ratio)	0.27	0.47	0.55	0.71	-
η_{sg}	Efficiency factor of the steam generator (%)	92	93	93	94	-
η_v	Part of the output thermal power of the steam generator which is lost with exhaust gases (%)	6	5	5	4	-
a	Coefficient in relation (14)	0.68125	0.58591	0.55846	0.49991	-
Q_{sg}	Output thermal power of the steam generators (MW)	3,528.2	3,753.0	4,996.4	2,874.9	15,152.5
Q_T	Output thermal power of the turbines (MW)	2,166.9	1,991.4	2,514.3	1,311.4	7,984/0
Q_{HP}	Thermal power of the heat pumps (MW)	236.7	207.3	276.0	125.8	845.8
N	Output electric power of the turbines (MW)	585.1	936.0	1,382.9	931.1	3,835.1
N_G	Output power of the electric generators (MW)	573.4	917.2	1,355.2	912.4	3,758.2
N_{HP}	Electric power consumed by the heat pumps (MW)	52.6	46.1	61.3	28.0	188.0
N_N	Electric power transferred to the power network (MW)	520.8	871.1	1,293.9	884.4	3,570.2
ΔN_G	Range of variation of the power of electric generators (MW)	62.6	95.6	148.8	87.6	394.6
ΔN_N	Range of variation of the power transferred to the electric power network (MW)	115.2	141.7	210.1	115.6	582.6

$$* Q_i = \frac{N_i}{\eta_G K}$$

The results of analysis of the variant with controlled electric power demonstrate the following. According to this variant, the total thermal power $\Sigma(Q_T + Q_{HP})$ that is transferred from the HPP to the heating system coincides with the total rated operating thermal power ΣQ_o , as must by relation (7). The total electric power transferred to the power network is reduced by 14 % as compared with the nominal operative conditions of HPP (without heat pumps). So, when the variant with controlled electric power is used, the installed electric power of the HPP is considerably underutilized. The thermal power of the plant turbines is also underutilized by 9.6 %, but this underutilization is compensated by additional thermal power generated by the heat pumps.

Generally, according to this variant, the total output power transferred outside by the plant illustrated in Figure is reduced by 4.5 % as compared with the total output power of the HPP without heat pumps, i.e., the reduction is quite substantial. Therefore, we may conclude that, possibly, the use of this variant is reasonable only if the electric power of the HPP is involved to eliminating problems arising in power systems, in particular, for controlling power generation in response to electric load demands. But this use requires an additional economic analysis. Positive solution on the use of this variant will depend on the pay for system (secondary) services supplied to consumers.

It should be emphasized that the powers of heat pumps presented in Table 1 are maximum possible for this variant with the specified initial parameters. These powers are represented as system parameters and, according to equations (13) and (17), depend on both the operative conditions and design parameters such as η_v , η_r , η_{Sg} , φ , and η_T . The values of these system parameters can be reduced only by removing a certain part of the heat pumps from service up to their complete exclusion. In this case, the HPP will work under the rated operative conditions. Note that, according to Table 1, the obtained range of variation of the electric power transferred to the power network is less by a factor of more than five as the corresponding range presented in [2].

Variant 2 (economical variant)

According to this variant (realized in [1]), the control system of the turbine power provides the generation of rated operating thermal power Q_T in

the presence of heat pumps in the scheme of HPP shown in Figure:

$$Q_T = Q_o, \quad (20)$$

where Q_o is calculated according to (6).

The relations connecting the operative conditions of the HPP according to Variant 2 are the following:

$$Q_N - Q_o - Q_{HP} = 0, \quad (21)$$

$$\eta_T Q_{Sg} - Q_o - N_o = 0, \quad (22)$$

$$N_G - N_N - N_{HP} = 0, \quad (23)$$

System (21) – (23) has an analytical solution:

$$Q_{Sg} = \frac{Q_o + N_o}{\eta_T}, \quad (24)$$

$$Q_{HP} = b Q_{Sg}, \quad (25)$$

$$b = \frac{\varphi \eta_r \eta_v}{(\varphi - 1) \eta_{Sg}}, \quad (26)$$

$$Q_N = Q_o + Q_{HP}, \quad (27)$$

$$N_{HP} = \frac{1}{\varphi} Q_{HP}, \quad (28)$$

$$N_N = \eta_G N_o. \quad (29)$$

The notation in equations (21) ... (29) is the same as those in dependences (1) ... (19). Relations (24) ... (29) were used for calculating the parameters characterizing the operative conditions of groups of HPP, determined in analyzing Variant 1, with the same initial data as in Table 1. The results of calculations for Variant 2 are presented in Table 2.

In contrast to Variant 1, the operative conditions of HPP with heat pumps according to Variant 2 are cost-justifiable. The thermal power of each group of HPP and their assemblage as a whole increases. This growth, expressed in relative values, is inversely proportional to the efficiency factor of the steam generators because, with increase in these factors, the relative power of exhaust gases

Table 2 - Operative conditions and attainable volumes of heat pumps at HPP in the Integrated Power System of Ukraine (the economical variant)

Parameter identifier	Parameter	Parameter value				Total
-	Initial steam pressure (MPa)	3.4	8.8	12.8	23.5	-
N_i	Installed electric power (MW)	795	1,266	1,880	1,250	5,191
N_o	Rated operating electric power (MW)	636.0	1,012.8	1,504	1,000	4,152.8
Q_i	Installed thermal power (MW)	3,004.5	2,748.6	3,487.9	1,796.5	11,037.5
Q_o	Rated operating thermal power (MW)	2,403.6	2,198.9	2,790.3	1,437.2	8,830
K	Specific production of electric power in operation of the turbine as a thermal power source (MW (el.) to MW(th.) ratio)	0.27	0.47	0.55	0.71	-
η_{Sg}	Efficiency factor of the steam generator (%)	92	93	93	94	-
η_v	Part of the output thermal power of the steam generator which is lost with exhaust gases (%)	6	5	5	4	-
b	Coefficient in relation (25)	0.068571	0.055299	0.055299	0.043769	-
Q_{Sg}	Output thermal power of the steam generators (MW)	3,896.9	4,117.6	5,505.5	3,124.6	16,644.6
Q_{HP}	Thermal power of the heat pumps (MW)	267.2	227.7	304.4	136.8	936.1
Q_N	Thermal power transferred to the heating system (MW)	2,670.8	2,426.6	3,094.7	1,574	9,766.1
N_G	Output power of the electric generators (MW)	623.3	992.5	1,473.9	980.0	4,069.7
N_{HP}	Electric power consumed by the heat pumps (MW)	59.4	50.6	67.7	30.4	208.1
N_N	Electric power transferred to the power network (MW)	563.9	941.9	1,406.2	949.6	3,861.6
ΔN_G	Range of variation of the power of electric generators (MW)	0	0	0	0	0
ΔN_N	Range of variation of the power transferred to the power network (MW)	59.4	50.6	67.7	30.4	208.1

decreases. The increment of thermal power reaches 11% for the group of steam generators with an efficiency factor $\eta_{Sg} = 92\%$ and 9.5% for the steam generators with an efficiency factor $\eta_{Sg} = 94\%$. The average increase in the thermal power of all assemblage of heat and power plants is estimated as 10.8%. It is reasonable to determine the total power that is transferred from all HPP to the power network and heating system. This power constitutes 12,899.7 MW under the rated operative conditions (without heat pumps) and 13,627.7 MW under the conditions with heat pumps (Variant 2). So, the total power increases by 5.6 %, i.e., the increase is substantial.

It is also important that the operative conditions of HPP according to Variant 2 can be used efficiently for the automatic control of frequency and power (ACFP) in power systems. If there is a deficiency of power, then the ACFP system switches off the heat pumps installed at HPP. In this case, the electric power transferred to the power network increases by 208.1 MW, resulting in partial or complete compensation of the formed power deficit. During the period when the ACFP system operates (15 minutes), the heating system receives 936.1 MW of thermal power less, but this decrease is compensated due to the accumulating capacity of heating systems and buildings of the consumers. The results of special energy-and-economic studies demonstrate that the ACFP systems based on consumers-regulators in the form of controlled heat-pump stations included to district heating systems provide cost effectiveness of about 1 billion of US dollars per year.

The results obtained enable us to make the following generalizations.

1. The operative conditions of HPP with heat pumps in their technological schemes according to Figure can be implemented by using two variants: the variant with controlled electric power and economical one.

2. The variant with controlled electric power provides the possibility to vary the electric power of HPP transferred to the power network in the range of 0 ... 14% of the rated output electric power (see

Table 1). Here, the value 14% corresponds to the maximum possible powers of heat pumps. However, this variation is possible due to reducing the output electric power of turbines by 9% and their thermal power by 9.6%. Therefore, the cost effectiveness of this variant can be ensured only under fairly rigid conditions, namely, in the case of high payments, established by the power system, for system services in satisfying the electric load demands.

3. The economical variant of the operative conditions of HPP with heat pumps is characterized by a high cost effectiveness. The total thermal and electric power transferred to the heating system and power network according to this variant increases by 5.6% as compared with the rated operative conditions, which guarantees its high cost effectiveness.

This effect can be even greater due to the use of heat pumps, working at HPP, as consumers-regulators in the ACFP system as a part of the Integrated Power System of Ukraine.

Bibliography

1. *Large-scale* heat pumps for Swedish municipal incineration plants, European Heat Pump News: The Newsletter of the European Heat Pump Concerted Action, Issue 2, August 1999. – P. 6 (Umeå, Sweden).
2. *Dubovskiy S.V., Levchuk A.P., Kadenskiy M.Y.*, Increasing the maneuver capabilities of power system by means of the use of heat pumps as regulators at heat and power plants, *Problemy Zahal'noi Enerhetyky*, No. 4(35), 2013. – P. 16.
3. *Sokolov E.Y., Brodianskiy V.M.*, Energy characteristics of heat transformation and cooling processes [in Russian], M., Energoizdat, 1981. – 320 p.
4. *Kulyk M.M., Bilodid V.D.*, Problems and perspectives of development of technologies based on heat pumps in Ukraine, *Problemy Zahal'noi Enerhetyky*, No. 14, 2006.- P. 7.
5. *Benenson E.I., Ioffe L.S.*, Dual-purpose steam turbines [in Russian], M., Energoatomizdat, 1986. – 271 p.

Надійшла до редколегії 25.02.2014