

B.M. Anwer, A.N. Alsammak

## An integrated series active power filter combined with a PV-battery system based on a fuzzy logic controller to enhance power quality for various linear and non-linear loads

**Introduction.** Rapid capacity development and the incorporation of new loads are adding complexity to the distribution power system. As a result, the distribution system faces additional power quality issues, particularly with increasingly sensitive equipment and distributed generation. **Problem.** Modern power systems face escalating power quality degradation due to non-linear loads. Voltage disturbances (sags, swells) and harmonic distortions directly affect the sensitive equipment, causing significant economic losses. The **goal** of this work is to design, model, and evaluate series active power filters (SAPFs) integrated with energy management for an independent solar storage system, using a multi-stage DC-DC converter. The objective focuses on mitigating voltage harmonics and grid disturbances resulting from diverse loads (linear, non-linear, and combined) and integrating renewable energy (PV). Control is achieved through an intelligent fuzzy logic controller (FLC) and a PI controller to ensure a stable DC voltage and reduce the total harmonic distortion (THD) of the voltage to less than 5%. **Methodology.** This study models and analyzes a unique SAPF configuration integrated with a PV-battery storage system utilizing MATLAB/Simulink. Outcomes of the proposed control, wherever the FLC regulates the DC-link voltage reference signals utilize the instantaneous reactive power theory. The suggested methodology entails simulation studies across four scenarios: an analysis of performance to keep voltage components and a comparison of the proposed SAPF performance with existing research on linear, non-linear, and combined loads. **Results.** Simulation results show the effectiveness of the control approach in mitigating the voltage THD level to less than 5% under various operating conditions that included the main supply voltage and loads, which satisfies the international PQ standards (IEEE Std. 519). The **scientific novelty** lies in the combination of a new 3-phase SAPF with a PV-battery system by FLC and a cascaded DC/DC converter. This allows effective voltage disturbance and harmonic compensation in various load situations without conventional transformers. **Practical value.** This research offers a robust solution for power quality problems in modern grids, reducing losses by ensuring stable, no-distortion power for sensitive industrial loads across varied operating conditions. References 46, tables 3, figures 19.

**Key words:** power quality, series active power filter, PV-battery system, fuzzy logic control, voltage disturbances, harmonic mitigation, linear and nonlinear loads.

**Вступ.** Швидке розширення потужностей та включення нових навантажень ускладнюють систему розподілу електроенергії. В результаті система розподілу стикається з додатковими проблемами якості електроенергії, особливо через дедалі чутливе обладнання та розподілену генерацію. **Проблема.** Сучасні енергосистеми стикаються зі зростаючим погіршенням якості електроенергії через нелінійні навантаження. Коливання напруги (провали, збільшення) та гармонічні спотворення безпосередньо впливають на чутливе обладнання, спричиняючи значні економічні втрати. **Метою** роботи є проектування, моделювання та оцінка послідовних активних фільтрів потужності (SAPF), інтегрованих з управлінням енергією, для незалежної системи сонячного накопичення енергії, з використанням багатоступеневого перетворювача постійного струму. **Мета** зосереджена на зменшенні гармонік напруги та коливань у мережі, що виникають внаслідок різних навантажень (лінійних, нелінійних та комбінованих) та інтеграції відновлюваної енергії (PV). Керування досягається за допомогою інтелектуального контролера з нечіткою логікою (FLC) та PI-контролера для забезпечення стабільної напруги постійного струму та зменшення загального коефіцієнта гармонійних спотворень (THD) напруги до менш ніж 5%. **Методологія.** Це дослідження моделює та аналізує унікальну конфігурацію SAPF, інтегровану з системою зберігання PV батарей, використовуючи MATLAB/Simulink. Результати запропонованого керування, де FLC регулює сигнали опорної напруги ланки постійного струму, використовують теорію миттєвої реактивної потужності. Запропонована методологія включає дослідження моделювання за чотирма сценаріями: аналіз продуктивності для підтримки складових напруги та порівняння запропонованої продуктивності SAPF з існуючими дослідженнями лінійних, нелінійних та комбінованих навантажень. **Результати** моделювання показують ефективність підходу до керування у зменшенні рівня THD напруги до менш ніж 5% за різних робочих умов, включаючи основну напругу живлення та навантаження, що відповідає міжнародним стандартам PQ (IEEE Std. 519). **Наукова новизна** полягає в поєднанні нового трифазного SAPF з системою PV батарей за допомогою FLC та каскадного перетворювача постійного струму. Це дозволяє ефективно компенсувати коливання напруги та гармоніки в різних ситуаціях навантаження без використання звичайних трансформаторів. **Практична значимість.** Це дослідження пропонує надійне рішення для проблем якості електроенергії в сучасних мережах, зменшуючи втрати, забезпечуючи стабільну потужність без спотворень для чутливих промислових навантажень за різних умов експлуатації. Бібл. 46, табл. 3, рис. 19.

**Ключові слова:** якість електроенергії, послідовний активний фільтр потужності, система фотоелектричних батарей, нечітка логіка керування, збурення напруги, зменшення гармонік, лінійні та нелінійні навантаження.

**Introduction.** Reliability is a crucial concept for utility companies and their customers in general. It holds particular significance for businesses operating in highly competitive environments because it directly affects profitability, a key driver in the industry. Although electrical transmission and distribution systems have attained a very high degree of dependability, disruptions cannot be completely eliminated. Any distortion in the voltage waveform can lead to operational issues with electrical and electronic devices [1]. To ensure uninterrupted production, users require a consistent sine wave shape, constant frequency, symmetrical and standard voltage value [2, 3].

The focus on improving efficiency and minimizing variations in industrial operations has resulted in more use of the complex equipment that is highly sensitive to voltage disturbances, such as voltage sags, voltage swells,

interruptions, and harmonics [4]. Voltage sags are considered the most critical, as sensitive loads are particularly sensitive to temporary voltage changes [5]. In some cases, these issues might result in the total stoppage of an entire production line, especially in high-tech industries like semiconductor manufacturing, causing significant economic losses for affected changes [2, 6].

Traditionally, solutions to address power quality issues relied on conventional passive filters [7]. However, their limitations, such as fixed compensation, resonance with source impedance, and challenges in tuning time-dependent filter parameters, have created a demand for active and hybrid filters [8]. Active filters offer better compensation compared to passive filters, and when combined with passive elements, they form hybrid filters that provide cost-effective and optimal solutions [2, 9].

As a result, the advancement of active filter technology has progressed to mitigate voltage-related power quality issues, especially in systems that include diode bridge converters with substantial DC-link capacitive filters [10]. Series active power filter (SAPF) is preferred in such applications. Although series filters efficiently remove voltage and current harmonics, they are not optimal for ensuring zero voltage regulation at the point of common coupling (PCC). Additionally, a series filter to handle voltage-related concerns is more efficacious than employing a shunt filter for better utilization of system ratings [2, 11]. Most addressing escalating challenges of power quality degradation in modern electrical systems have been solved by using FACTS devices, such as a 3-phase SAPF for power distribution systems [7]. The impact on power supply and quality of energy with the growing number of power electronic devices, which are not linear in nature and can comprise voltage deviation and harmonic distortions, is a serious issue, and thus, the reliability and performance of electrical distribution systems are affected [2, 12].

To mitigate the detrimental effects experienced by the systems, the proposed architecture in this study possesses unique characteristics and capabilities for energy management of stand-alone photovoltaic (PV)-battery energy storage systems integrated with the SAPF. The objective of this cooperative control is to effectively counteract both sag and swell voltage, as well as harmonic distortions in load voltage, thereby ensuring superior power quality and overall stability of the power system.

**Review of the literature.** The following section reviews the most significant research works in the literature on SAPFs and hybrid SAPF configurations for improving PQ. As outlined in [13], the methodology analyzed fuzzy logic-based phase-locked loops (PLLs) and linear controllers (RST and PID) for SAPF suppression of non-linear load voltage dips, with the most attention being given to fuzzy hysteresis band control, where a performance comparison with traditional techniques using higher complexity was carried out. The work [14] proposes a SAPF based on an adaptive fuzzy logic controller. It aims at improving the power quality in stand-alone wind/solar power systems by eliminating the voltage problems such as modulation, surges, distortion, and imbalance, resulting from non-common loads. The power sources are used to prop up the AC side to minimize voltage distortion and to satisfy the standard of IEEE 519-1992 as well as to improve the use of renewable energy sources. A key contribution of [15] is a new control strategy, fuzzy slide mode pulse width modulation (FSMPWM), compared with PI control, for a series hybrid active power filter to enhance power factor. FSMPWM can reduce the total harmonic distortion (THD) and perform better than a hysteresis controller. Another advantage of the FSMPWM is that it can suppress noise, standardize switching frequency, and cope with voltage dips/spikes. This is confirmed via MATLAB simulation based on IEEE-519 laws. The study [16] highlighted how hybrid active power filters with sliding mode control were capable of managing harmonic pollution due to non-linear loads under smart grid environment development, and support was given to active versus passive alternatives. The work [17] confirms the superiority of the ANFIS-based control of the SAPFs for harmonics and voltage disturbances mitigation. By

extensive simulations and experimental tests, it is shown that the ANFIS controller has proven superior to the backstepping sliding mode control by minimizing the THD, thereby increasing the power quality at the grid level. Its robustness and flexibility make it a good candidate. Building upon previous work, [18] developed a new control algorithm for SAPFs in the low-voltage distribution grid serving a voltage source non-linear load in order to use the feeder impedance factor practically calculated via simulation and experiment. The authors of [19] presented an improved second-order generalized integrator controlled series hybrid active power filter for harmonic current suppression in 3-phase interfaces, involving PV systems showing substantial THD drop. The results from [20] investigated hybrid SAPFs, using an adaptive neuro-fuzzy inference system for better power quality control in power grid-connected systems with non-linear loads. Further analysis by [21] studied the influence of power electronics-generated harmonics and also confirmed in simulation as well as measurement that shunt and SAPF can suppress these distortions. Specifically, [22] focused on presenting the improved quality of power by connecting SAPFs to the proton exchange membrane fuel cell through advanced AI-based control in both conventional and PV-integrated distribution systems. The work [23] concentrated on SAPFs to alleviate source-produced voltage, and the matrix pencil method was reported as a superior method compared to traditional methods in terms of THD reduction. In general, these investigations constitute an important part of the work on the advancements of SAPFs and their hybrid forms for power quality conditioning in different electrical systems. The proposed PV-battery system without an MV transformer employs a multi-stage DC-DC converter and an integrated energy management control concept [24]. A PI controller optimizes PV DC voltage [25, 26] under various loads.

By directly addressing the adverse impacts of non-linear power electronics, this integrated SAPF and PV-battery system offers a robust, efficient solution to the growing challenges of maintaining power quality in contemporary electrical systems.

The **goal** of this work is to design, model, and evaluate series active power filters (SAPFs) integrated with energy management for an independent solar storage system, using a multi-stage DC-DC converter. The objective focuses on mitigating voltage harmonics and grid disturbances resulting from diverse loads (linear, non-linear, and combined) and integrating renewable energy (PV). Control is achieved through an intelligent fuzzy logic controller (FLC) and a PI controller to ensure a stable DC voltage and reduce the THD of the voltage to less than 5 %.

**Active power filter (APF).** The core operating principle of active filtering is based on the extraction and subsequent injection of reference signals that include prominent harmonics at the PCC. This complex process is executed using specialized modulation methods, including pulse width modulation (PWM). In shunt APF applications, source current harmonics are predominant, whereas voltage harmonics are rather small and are not substantially influenced by non-linear loads [27]. Consequently, numerous researchers inadvertently employ classic SAPFs with sinusoidal voltage sources and non-linear loads (Fig. 1), configurations typically intended for shunt APF applications [28, 29].

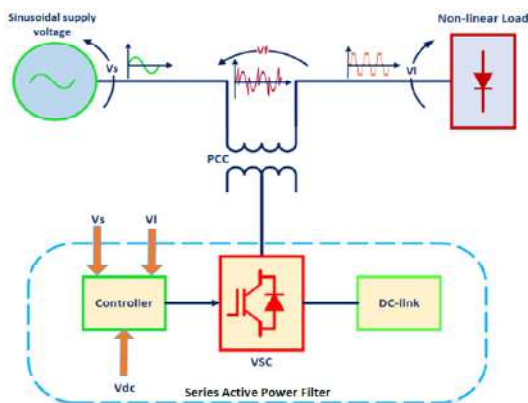

Fig. 1. Classic SAPF

Conversely, in the context of SAPFs, when appropriately configured under linear load conditions with a voltage source exhibiting significant harmonic distortion, the resultant current waveform inherently mirrors the source voltage's harmonic profile. This phenomenon may compromise the efficacy of reference-signal extraction techniques, particularly in linear load scenarios [29]. To address this challenge, a comprehensive investigation into the applicability and robustness of extraction methodologies within SAPF frameworks is imperative, with emphasis on linear load configurations (Fig. 2).

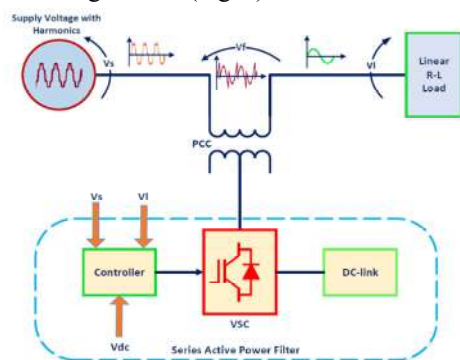

Fig. 2. Modern SAPF

The present study undertakes a rigorous analysis of linear, non-linear, and hybrid (combined linear and non-linear) loads conditions, while also accounting for source voltage anomalies such as sags, swells, and significant harmonic distortion (Fig. 3). The characteristics of SAPF types can be clarified through the flowchart (Fig. 4).

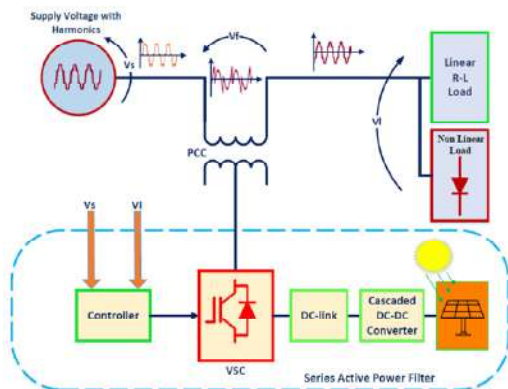

Fig. 3. Developed SAPF

When checking the flowchart, notice that the advanced SAPF excels at enhancing power quality, making it well-suited for environments with distorted

source voltage and distorted current loads. Its flexible and precise operation effectively mitigates voltage distortion originating from both the source voltage and the flow of distorted current through the system's impedance, capably handling linear, non-linear, and combined load types. The modern SAPF employs contemporary technology to improve power quality and is also effective in situations with distorted source voltage.

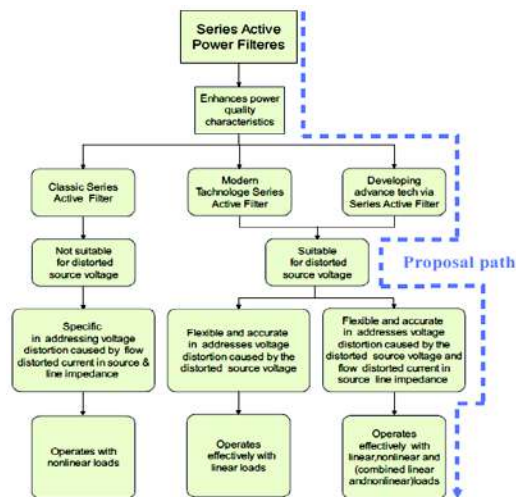

Fig. 4. Flowchart characteristics of SAPFs with proposal path

It offers flexible and accurate correction of voltage distortion caused by the distorted source voltage and functions efficiently with linear loads. In contrast, the Classic SAPF improves power quality but is not ideal for distorted source voltage conditions. It specifically targets voltage distortion resulting from distorted current flow within.

**Medium-voltage grid integration of PV systems through advanced DC-DC conversion topologies.** The escalating concerns surrounding environmental degradation and the limitations of conventional energy sources have propelled PV technology to the forefront of renewable energy research and deployment. Over the past decade, significant advancements in solar cell efficiency and manufacturing processes have established PV power generation as a compelling alternative and complementary energy resource, particularly within hybrid energy systems [25, 30]. This rapid expansion of PV adoption is further fueled by the increasing demand for distributed generation, highlighting the crucial role of solar energy in meeting renewable electricity targets [31].

However, the growing integration of distributed solar PV generation into low- and medium-voltage distribution networks introduces a range of technical challenges. These include alterations in voltage profiles (such as voltage rise and imbalances), potential overloading of feeder components, increased activity of voltage regulation devices, voltage fluctuations, power quality degradation, elevated energy losses, and a reduction in overall network reliability [23, 26]. Concurrently, ongoing innovations in PV technology have led to significant cost reductions, with PV module prices experiencing a substantial decline (80–85 % between 2009 and 2016) [32], further accelerating their adoption in these years until now.

A critical component in optimizing the performance of PV systems, particularly under varying solar irradiance and temperature conditions, is the maximum power point tracking (MPPT) system. Given the inherent low efficiency of PV modules in suboptimal conditions and their non-

linear voltage-current characteristics, an MPPT system is indispensable for extracting maximum power output. Usually adopting algorithms of perturb and observe for its simple operation, the MPPT system also requires a joint utilization DC-DC converter to behave as a control interface [33, 34]. This converter adapts its duty cycle according to the variations of the environmental conditions in order to operate continuously at the MPPT [35]. There are many different types of DC-DC converter topologies, such as buck, boost, buck-boost, Cuk, Sepic, etc., which individually have their own special characteristics and limitations for the dedicated application [36, 37].

In order to efficiently control the output voltage of PV modules and to achieve the maximum power point tracking, it is necessary to have a DC-DC converter. This research focuses specifically on the boost converter topology, known for its ability to step up the input voltage level. Boost converters find widespread application in battery-powered systems where higher operating voltages are required for electronic devices. The fundamental principle of power transfer in this converter relies on the interaction of a power switch, an inductor, a capacitor, and a diode, with power flow managed through the switching action of the power switch. Output voltage regulation is achieved by controlling the duty cycle of the switch using PWM at a fixed switching frequency [36, 38].

The increasing penetration of PV generation has profoundly impacted power system operation. While distributed generation offers numerous benefits, the intermittent nature of solar resources presents challenges for distribution system operators concerning power quality, efficiency, and grid stability. This evolving scenario necessitates a shift from solely focusing on active power generation from PV systems to exploring their reactive power capabilities for enhanced grid support and voltage regulation. Recent research has explored generalized optimization frameworks applicable to various distribution networks, integrating dynamic PV control strategies [39]. The growing awareness of energy security and climate change has further spurred the proliferation of distributed energy resources, with PV systems gaining prominence in low-voltage distribution networks due to their decreasing costs and lack of moving parts [40, 41].

In the context of medium-voltage distribution networks, DC-DC converters play a crucial role in harnessing energy from PV panels. The standard DC voltage for residential system between 400–600 V, while the commercial PV modules typically have voltage limitations below 1 kV, in addition, the utility-scale PV may go up to 1.5 kV and DC bus voltages are often significantly higher; high step-up ratio DC-DC converters are required.

One effective approach to achieve the required high voltage gains is through the utilization of multiple cascaded submodules from low voltage DC (LVDC) to medium voltage DC (MVDC). Three primary cascaded DC-DC converter configurations exist: the input-independent output-series (IIOS) type, the low-voltage bus-based (LVBB) type, and the two-stage conversion (TSC) type, as shown in Fig. 5–7 [24, 42].

The more efficient proposed multiport cascaded converter, which includes capacitors and battery storage groups (Fig. 8). The capacitors handle the high-frequency ripple and the transient response. This method gives a more efficient and reliable MVDC supply.

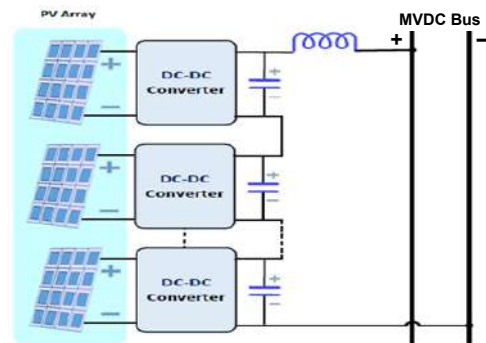

Fig. 5. Multiport cascaded converter type IIOS for MVDC

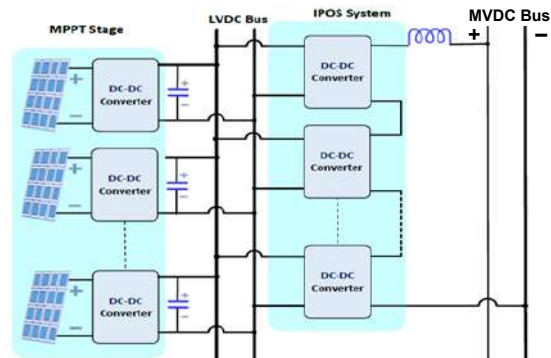

Fig. 6. Multiport cascaded converter type LVBB for MVDC

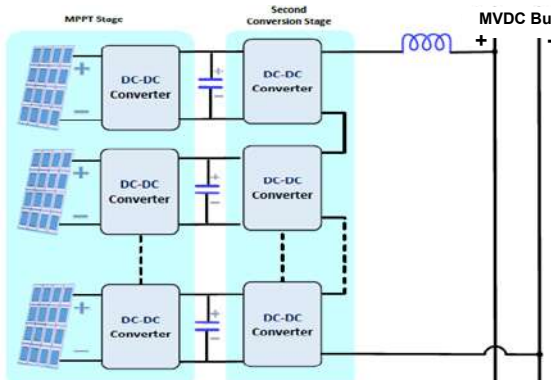

Fig. 7. Multiport cascaded converter type TSC for MVDC

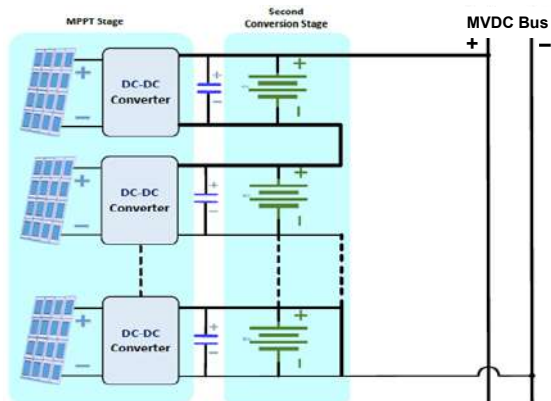

Fig. 8. Proposed multiport cascaded converter for MVDC

The proposed type of power system architecture utilizes a PV array to charge a battery bank through a boost DC-DC converter. This specific converter topology is employed to step up the voltage from the PV array to the required charging voltage of the battery. The suggestion used batteries have a capacity of 16.5 MW over 10 min. It can be increased if more support time is needed. A PI controller meticulously regulates the duty cycle of the boost converter's switching elements. This

closed-loop control ensures a stable and consistent DC voltage is maintained across the battery terminals, compensating for variations in solar irradiance and battery state-of-charge. To construct a cascaded system, multiple identical units, each encompassing the PV array, a boost DC-DC converter with PI control, and a battery bank, are connected in series. This serial connection allows for a scalable increase in the overall system voltage output, offering enhanced flexibility for higher voltage applications and facilitating modular design and maintenance. The following section will detail how the cascaded system's output voltage is accurately controlled and explain the principles for determining the necessary number of stages to achieve target voltage levels.

**Control system.** The control system has been split into two stages: first, control of the DC link and reference signal extraction using a conventional PI controller, and second, control of the DC link stages using an intelligent FLC. In DC link systems, voltage regulation is a critical aspect, achievable through either external or internal DC sources. When an internal source is utilized, a supplementary control circuit becomes essential to maintain the DC link voltage at a predefined reference, necessitating the feedback of the V-DC value to the controller. However, for the scope of this investigation, an external DC source is considered. Conventional control methodologies often face limitations in non-linear systems due to their reliance on precise mathematical models. In contrast, FLC offers a significant advantage by its inherent capacity to process data characterized by uncertainty, imprecision, and even apparent contradictions [14, 15]. FLCs emulate human-like control reasoning, diverging from traditional controllers by obviating the need for a rigorous mathematical model to address the inherent vagueness and uncertainty frequently encountered in linguistic problem formulations. Fuzzy logic demonstrates proficiency in representing uncertain and imprecise system knowledge, while fuzzy control enables decision-making even with uncertain inputs or outputs, based on a set of imprecise rules [43, 44].

The ANFIS, a hybrid intelligent control architecture, synergistically integrates the interpretability of fuzzy logic with the adaptive learning capabilities of neural networks. This integration facilitates the realization of robust, self-optimizing control frameworks. Grounded in a Takagi-Sugeno-type fuzzy inference model, ANFIS eliminates reliance on manual rule formulation and expert-driven parameter tuning, thereby significantly enhancing adaptability and operational efficiency in complex, non-linear environments [45].

In the current work, an ANFIS creates an FLC that has been specifically designed for seven-stage DC-link voltage regulation. The input-output data set for training ANFIS contains two inputs and one output. Four Gaussian membership functions characterize both input variables. The training error is about  $3.9 \cdot 10^{-3}$  with 50 epochs. The designed structure of the fuzzy logic controller is depicted in Fig. 9. This system employs two critical input variables load current (ranging from 1.4–11.5 kA) and THD (0–22.8 %) to generate a single control output. This output undergoes saturation and iterative error minimization, converging to approximately zero.

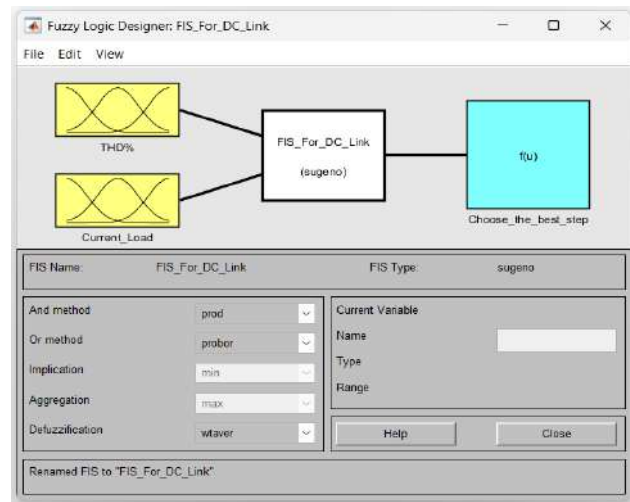

Fig. 9 The designed structure of the fuzzy logic controller

The computed control signal dynamically determines the minimum DC voltage amplitude, ensuring compliance with active power demands under varying operating conditions. This is achieved via a demultiplexer (Demux) driven activation mechanism that selectively engages a predefined number of cascaded power-stage modules. The power circuit (Fig. 10) comprises seven series-connected stages. By dynamically adjusting the number of active stages, the system achieves precise output voltage regulation while compensating for losses and maintaining stability during voltage sags, swells, or harmonic distortions.

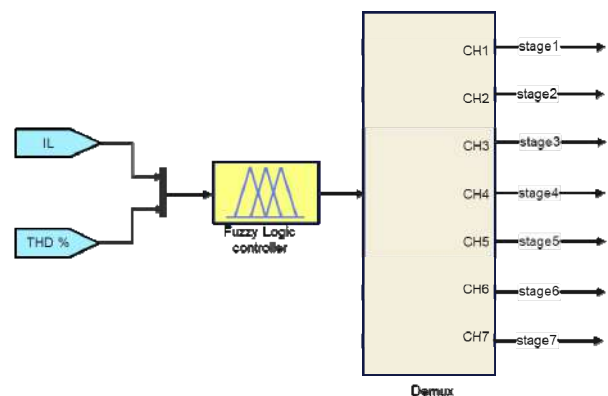

Fig. 10 The designed fuzzy logic controller with Demux

**Control of voltage extraction.** The SAPF is connected in series with the power circuit via a transformer with a 1:1 turn ratio. The primary elements of the SAPF are the voltage source inverter (VSI), the DC-link, and the control algorithm. IGBT transistors are the predominant switching devices used in the VSI module. For this investigation, PWM was used as the modulation method. Under conditions where standard power equations become invalid, Akagi theorized that instantaneous reactive power theory (IRPT) transforms into a theoretical framework used in a series filter, operating as a dual  $d-q$  theory for regulation. This theoretical framework entails the incorporation of a current source, either at the source or load, to ensure sinusoidal current waveforms inside the circuit, thereby isolating harmonic content exclusively within the voltage signal [23].

The MATLAB/Simulink for the proposed model that included the sample power system with the proposed SAPF, controlled by a fuzzy logic controller is shown in Fig. 11.

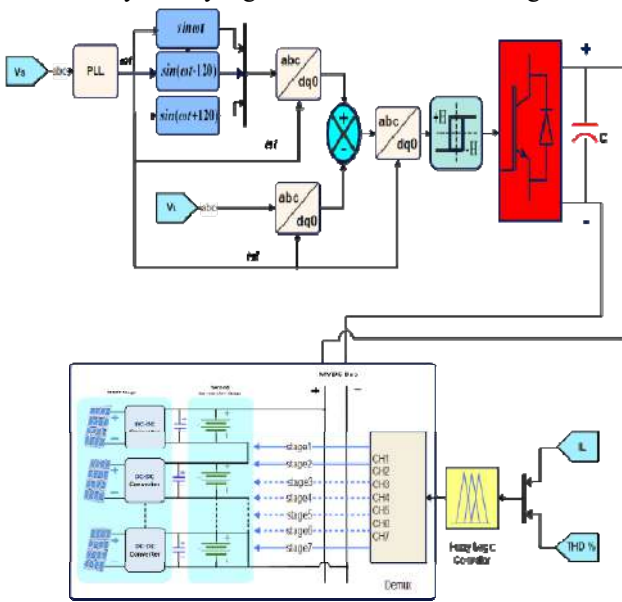

Fig. 11. Control system of compensator voltage extraction

The control circuit depicted in Fig. 11 derives the reference signal from the source voltage, which is fed into a PLL to extract the instantaneous phase angle ( $\omega t$ ). This phase angle serves as the synchronization basis for generating independent voltage sources within the system. Subsequently, the voltages of both the independent sources and the load are transformed from the 3-phase (ABC) reference frame to the synchronous dq0 (direct-quadrature-zero) reference frame using the extracted  $\omega_t$  [46]. A subtraction operation is then performed between the dq0 components of the load voltage and those of the independent sources. The resulting difference, representing the required compensation signal, is transformed back from the dq0 frame to the 3-phase (ABC) domain.

This compensation signal addresses harmonic distortions, mitigates voltage sag by injecting

supplementary voltage, or suppresses voltage swell by subtracting excess components. These disturbances originate from the primary power source. The compensation process is implemented via a SAPF, which utilizes a voltage source converter (VSC) operating under a hysteresis PWM control strategy. The VSC is powered by an external PV-DC link, and its switching is triggered by the reference signal generated through the aforementioned control steps. Compensation is injected into the power line via a series-connected converter, ensuring that the voltage delivered to the load remains sinusoidal, free of distortions, and compliant with high power quality standards.

**Proposed simulation.** This section presents a computational analysis of the proposed SAPF topology using MATLAB/Simulink. The simulation framework, depicted in Fig. 12, incorporates the parameters detailed in Table 1. The voltage source is configured to emulate a distorted grid supply; the series filter block incorporates a 3-phase 1:1 isolating transformer. The controller unit incorporates the extraction algorithm based on IRPT, PWM generation, and a seven-stage cascaded DC-DC converter topology. This converter, regulated by a PV system, achieves medium-voltage levels through operational control enabled by a demultiplexing unit for signal routing and an FLC system, which enhances dynamic stability and transient response.

Table 1

Simulation parameters for the proposed design

Parameters	Range
Source voltage and frequency	6600 V, 50 Hz
Source impedance	0.01 mH, 0.05 $\Omega$
Coupling reactance	1 mH
Coupling capacitance with resistance	2000 $\mu$ F, 1 $\Omega$
DC link voltage	(5000–13000) V
One-stage linear load	5 mH, 1 $\Omega$
One-stage non-linear load	3 mH, 6 $\Omega$
Transformers	6600Y / 6600Y

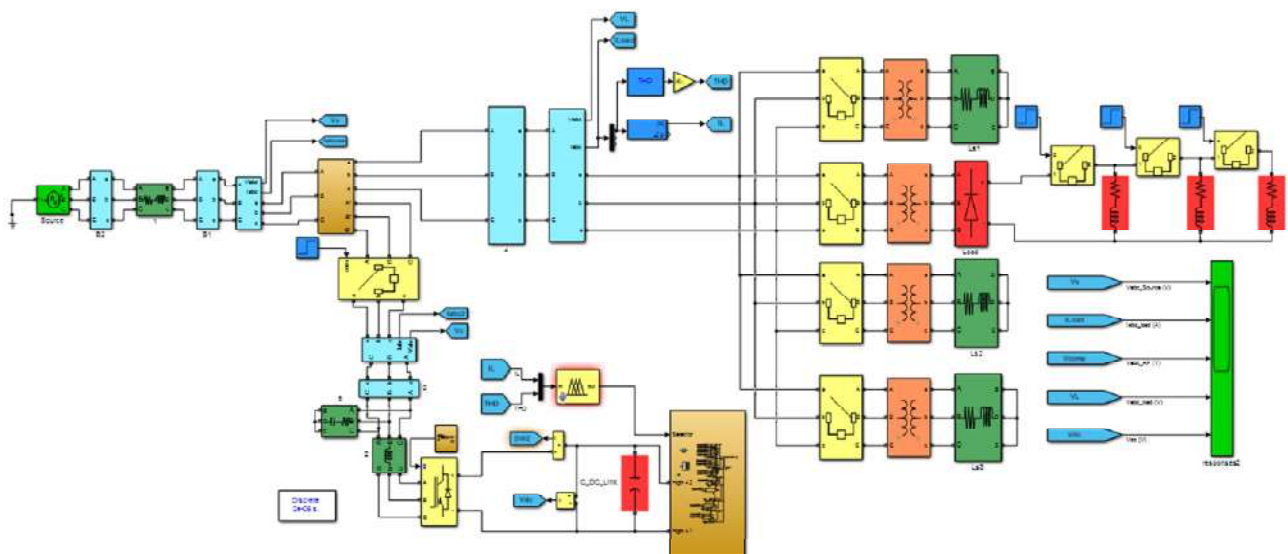

Fig. 12. Proposed SAPF in MATLAB/Simulink

To validate the efficacy of the proposed SAPF-based extraction technique **comprehensive simulations**

were conducted across four operational scenarios involving diverse load conditions.

1) First scenario.

This study evaluates the SAPF effectiveness in mitigating harmonic distortions and transient anomalies within a harmonically distorted grid. The system, with consistent voltage source properties (Table 2), is subjected to a 3-step non-linear load (NL1, NL2, NL3) (Fig. 13). Using fast Fourier transform (FFT), the SAPF's ability to suppress voltage harmonics from both load and source, compensate for harmonic source issues (Fig. 14), address voltage sags/swells, and counteract voltage droop due to source impedance is rigorously analyzed. Crucially, an FLC dynamically manages DC-link stages, ensuring stable power delivery to sensitive equipment despite varying load conditions.

Table 2

The dynamic characteristics of the source voltage over time for all scenarios

Voltage source	Time, s
Normal voltage without SAPF	0–0.1
Normal voltage with SAPF	0.1–0.2
Decrease 25 % voltage (sag)	0.2–0.4
Normal voltage with SAPF	0.4–0.6
Increase 25 % voltage (swell)	0.6–0.8
Normal voltage with SAPF	0.8–1
Normal voltage with SAPF	1–1.2
Normal voltage with SAPF	1.2–1.4
Harmonic source	1.4–1.6

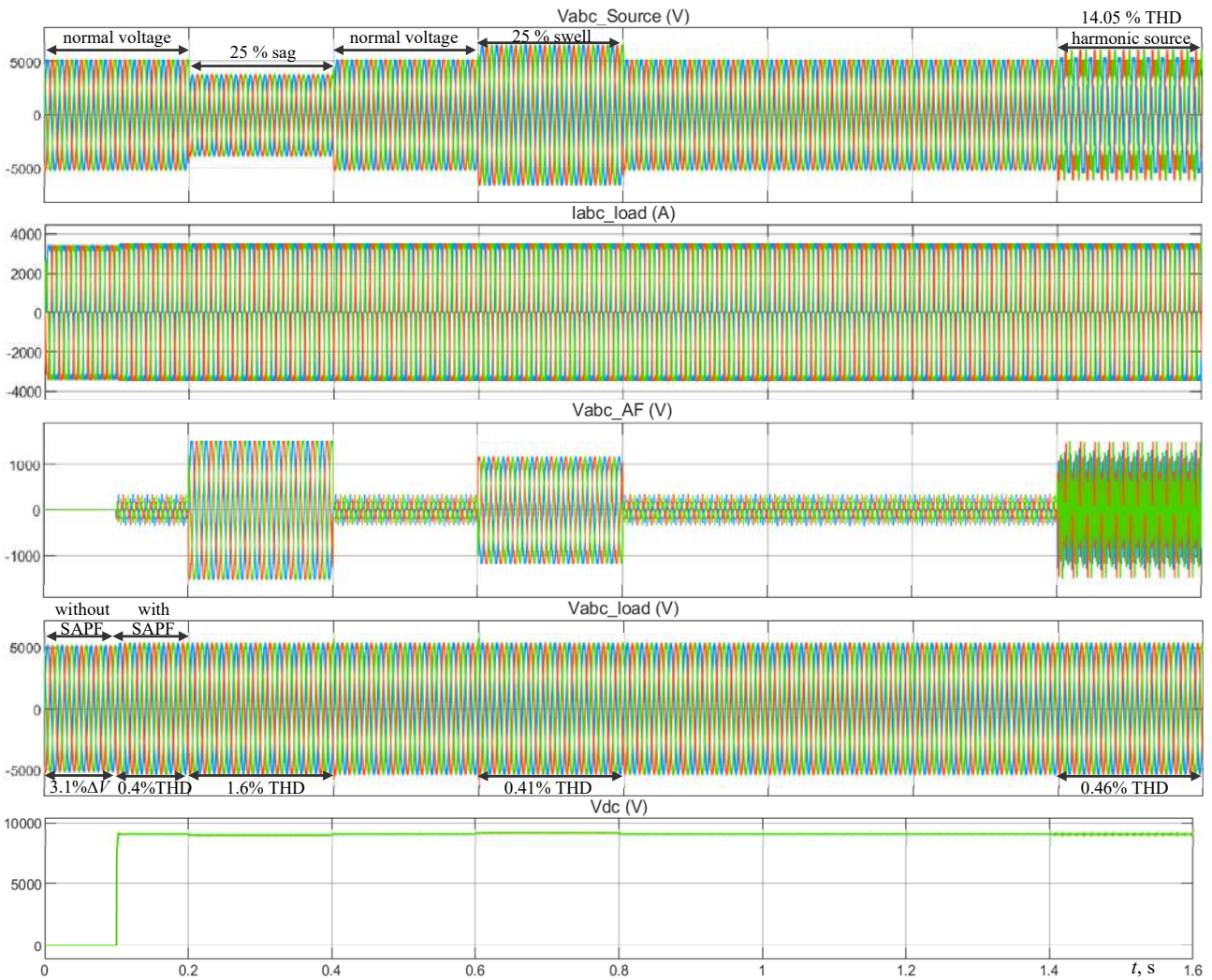

Fig. 13. Voltage waveforms and load current scenario 1

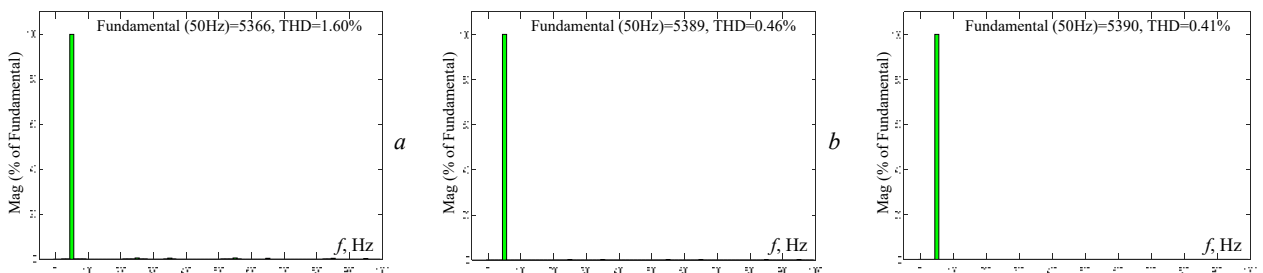

Fig. 14. Vabc\_load FFT analysis scenario 1: a – during sag source; b – during swell source; c – during harmonic source

2) Second scenario.

This assessment evaluates the SAPF effectiveness under high linear loads and grid harmonic distortion.

The system, using consistent voltage source properties (Table 2), undergoes a 3-step linear load (L1, L2, L3) (Fig. 15). The focus is on mitigating source

harmonics, compensating for transient disturbances, and suppressing voltage drops from source impedance.

FFT analysis details the results as shown in Fig. 16. FLC optimizes DC-link stage selection to maintain voltage quality for linear loads.

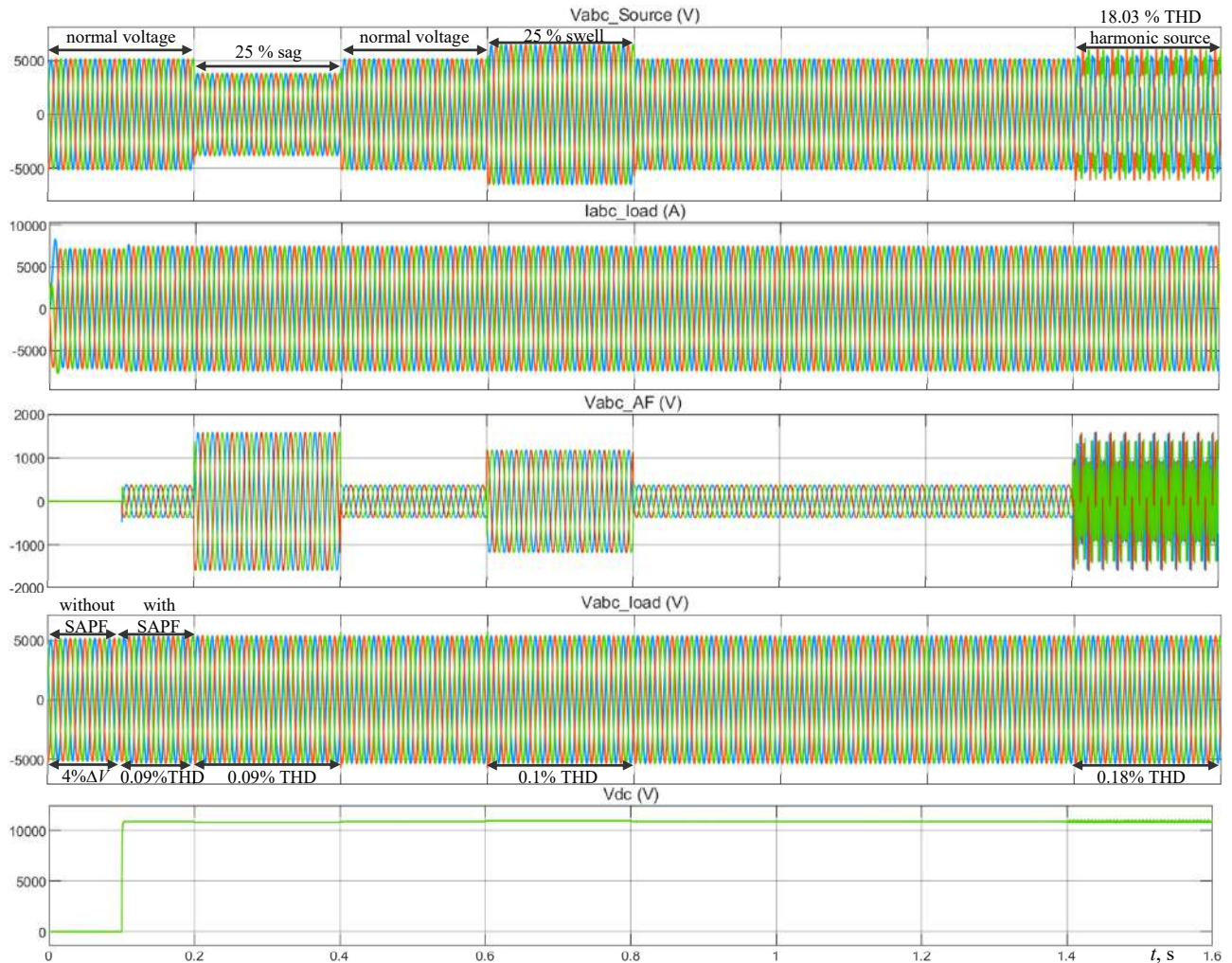

Fig. 15. Voltage waveforms and load current scenario 2

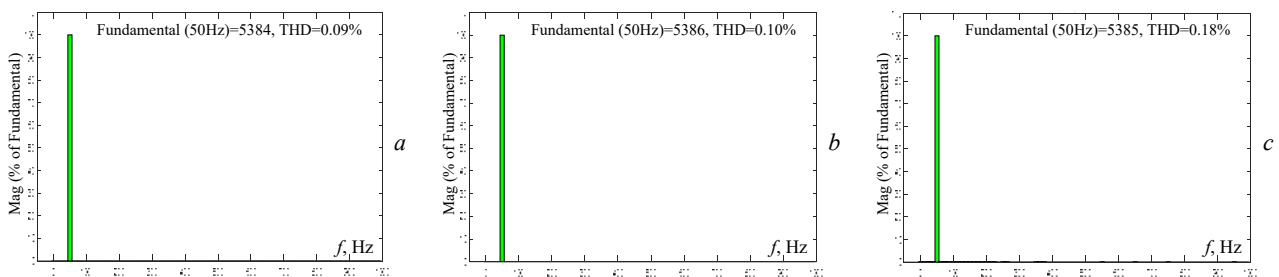

Fig. 16.  $V_{abc\_load}$  FFT analysis scenario 2: *a* – during sag source; *b* – during swell source; *c* – during harmonic source

3) Third scenario.

This investigation assesses the SAPF's robustness under combined linear (L1, L2, L3) and non-linear (NL1, NL2, NL3) loads, with consistent voltage source properties (Table 2) (Fig. 17).

It evaluates the system's capacity to attenuate harmonics, address transient disturbances, and mitigate voltage drop in highly complex conditions.

A fuzzy-controlled DC-link adaptation ensures consistent performance under extreme load demands. The primary focus remains on mitigating source harmonics, compensating for transient disturbances, and suppressing voltage drops caused by source impedance.

FFT analysis provides detailed results (Fig. 18).

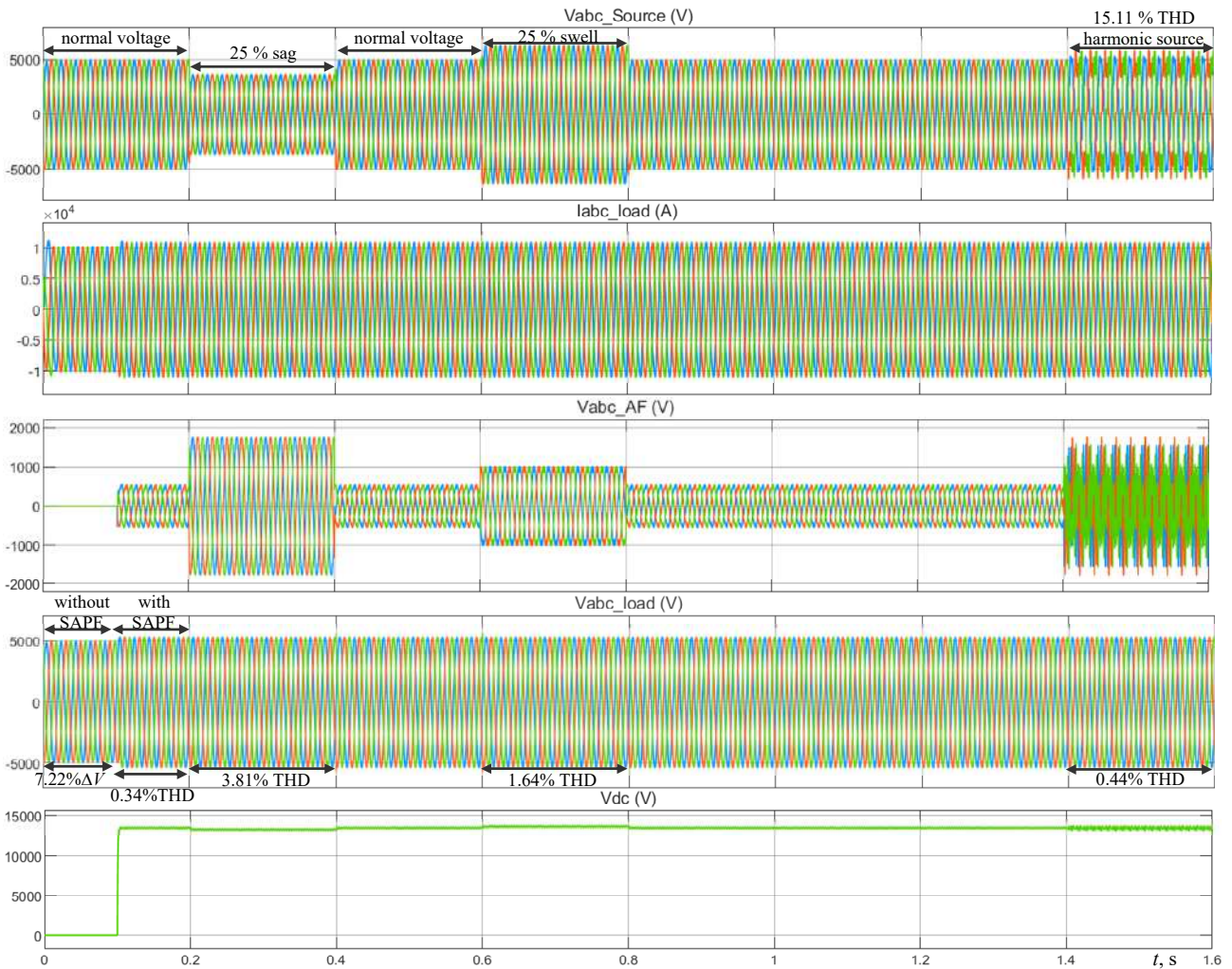

Fig. 17. Voltage waveforms and load current scenario 3

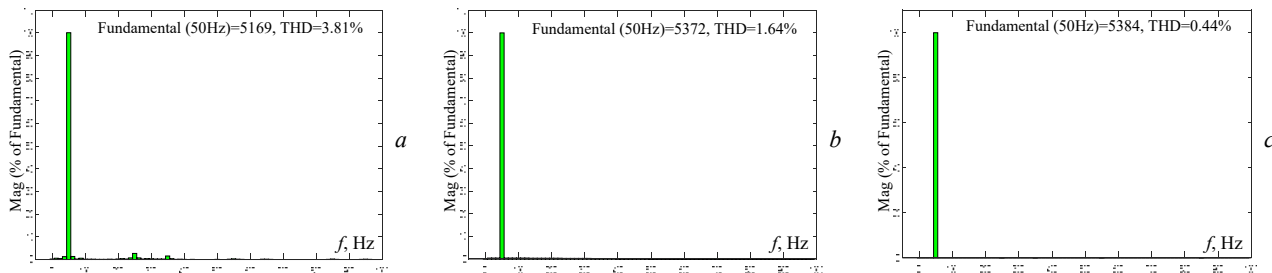

Fig. 18.  $V_{abc\_load}$  FFT analysis scenario 3: *a* – during sag source; *b* – during swell source; *c* – during harmonic source

4) Fourth scenario. This section synthesizes the preceding analyses to demonstrate the precision of the SAPF and the accuracy of its DC-link voltage regulation (Fig. 19). The fuzzy logic control system dynamically selects the optimal DC-link stage by assessing load characteristics (magnitude and type) (Table 3), and the load voltage THD. This adaptive selection ensures

efficient and precise compensation. Collectively, the simulations validate the SAPF's capability to enhance voltage quality across diverse load and grid conditions. FLC plays a pivotal role in optimizing DC-link dynamics, thereby ensuring both system stability and effective harmonic suppression.



Fig. 19. Voltage waveforms and load current for the fourth scenario

Load variations within the fourth scenario

Time, s	Loads type
0–0.1	NL1 without SAPF
0.1–0.2	NL1 with SAPF
0.2–0.4	NL2
0.4–0.6	NL3
0.6–0.8	NL1+ NL2+ NL3+ L1
0.8–1	NL1+ NL2+ NL3+ L1+ L2
1–1.2	NL1+ NL2+ NL3+ L1+ L2+ L3
1.2–1.4	L1+ L2+ L3
1.4–1.6	L1+ L2+ L3

**Results discussion.** This study aims to evaluate the performance of a SAPF in mitigating power quality disturbances, including voltage sags, swells, and harmonic voltage sources. The voltage source values over time will be set according to the parameters listed in Table 2.

In the first scenario, the experimental results of this scenario demonstrate a significant improvement in the voltage waveform under non-linear load conditions following the introduction of the successive effective filter. The voltage stabilizing to the source value,

Table 3

indicating successful compensation for voltage drops, evidences this improvement (e.g., up to 3.1 %  $\Delta V$ ) at the source without the use of SAPF (Fig. 13). Furthermore, FFT analysis, as Fig. 14,*a,b,c* confirms the system's efficiency in managing the load voltage, with observed THD values of 1.6 % during voltage sag, 0.41 % during voltage swell, and 0.46 % in the presence of a harmonic source exhibiting a 14.05 % THD

In the second scenario, the results of this scenario demonstrate a significant improvement in the voltage waveform with a high linear load after the introduction of the successive effective candidate. This improvement is evidenced by the voltage's stabilization to the source value, indicating successful compensation for voltage drops, which evidences this improvement (e.g., up to 4 %  $\Delta V$ ) at the source without the use of SAPF (Fig. 15). Moreover, the FFT analyzer verifies that the system efficiently handles the load voltage, according to the following detected THD: 0.09 % for voltage sag, 0.1 % during voltage swell, and 0.07 % with a load-source that injects 18.03 % THD. These THD values are shown in Fig. 16,*a,b,c*.

In the third scenario, the results of this scenario demonstrate a significant improvement in the voltage waveform under combined 3-stage linear and 3-stage non-linear loads, with consistent voltage source properties (Table 2) after the introduction of the successive effective candidate. This improvement is evidenced by the voltage's stabilization to the source value, indicating successful compensation for voltage drops, which evidences this improvement (e.g., up to 7.22 %  $\Delta V$ ) at the source without the use of SAPF (Fig. 17). Furthermore, the FFT analyzer confirms the system's efficiency in managing the load voltage, with the observed THD measured 3.81 % during voltage sag, 1.64 % during voltage swell, and 0.44 % in the presence of a harmonic source exhibiting a 15.11 % THD. These specific THD values are visually represented in Fig. 18, a, b, c.

In the fourth scenario, this section synthesizes prior analyses to demonstrate the efficacy of the SAPF and the precision of its DC-link voltage regulation. This is observed across diverse load conditions, as comprehensively presented in Table 3 and visually depicted in Fig. 19. The FLC dynamically determines the optimal harmonic compensation phase, and the quality of compensation is directly affected by the THD value. This type of adaptive control allows an effective, highly accurate compensation that is to be held stable below 5 % THD, in line with industry levels. Besides, the installation of SAPF helps to reduce the voltage drop developed across the source impedance, which in turn enhances the overall performance of the system.

**Conclusions.** This paper presents a novel 3-phase SAPF topology to address the increasing challenges of power quality deterioration in modern electrical systems, including electric power distribution networks. The proposed SAPF, the sole SAPF integrated with PV-battery energy storage, significantly enhances power quality. The outcome is highly effective in mitigating voltage abnormalities such as sags and swells, as well as filtering harmonic distortions in load voltage across various load circumstances (linear, non-linear, and mixed).

The THD values were measured well below the 5 % over the whole frequency range, 5 % (e.g., 1.6 % during sag, 0.41 % during swell, and 0.46 % with a harmonic source for non-linear loads), validating its efficiency. A key innovation is using an FLC system for dynamic DC-link voltage regulation and optimal harmonic compensation, which eliminates the need for medium-voltage transformers. The results confirm the SAPF's capability to ensure enhanced power quality, overall system stability, and proficient voltage management even during significant voltage drops (up to 7.22 %  $\Delta V$ ) at the source without relying on conventional SAPFs. This robust and efficient solution offers a promising direction for maintaining optimal power quality in contemporary electrical grids. This work provides a future recommendation to enhance the efficiency and sustainability of the proposed system by adding a battery management system (BMS), which aims to precisely coordinate charging and discharging operations among the energy storage units (batteries). Implementing a BMS ensures a balanced distribution of the stored energy consumption, thereby avoiding uneven stress on individual units. Practically speaking, this extends the operational lifespan of the batteries (number of cycles) and improves the overall performance and reliability of the energy storage system.

**Acknowledgment.** The authors would like to express their sincere gratitude to the University of Mosul, College of Engineering, Department of Electrical Engineering, for their invaluable assistance with this effort.

**Conflict of interest.** The authors declare that they have no conflicts of interest.

#### REFERENCES

1. Salleh Z.M.T., Alsammak A.N.B., Mohammed H.A. Enhancing Power System Transient Stability Using Static Var Compensator Based on a Fuzzy Logic Controller. *Journal Européen Des Systèmes Automatisés*, 2024, vol. 57, no. 6, pp. 1565-1572. doi: <https://doi.org/10.18280/jesa.570603>.
2. Chaudhari M.A., Chandraprakash. Three-phase Series Active Power Filter as Power Quality Conditioner. *2012 IEEE International Conference on Power Electronics, Drives and Energy Systems (PEDES)*, 2012, pp. 1-6. doi: <https://doi.org/10.1109/PEDES.2012.6484387>.
3. Zorig A., Babes B., Hamouda N., Mouassa S. Improving the efficiency of a non-ideal grid coupled to a photovoltaic system with a shunt active power filter using a self-tuning filter and a predictive current controller. *Electrical Engineering & Electromechanics*, 2024, no. 6, pp. 33-43. doi: <https://doi.org/10.20998/2074-272X.2024.6.05>.
4. Qasim A.Y., Tahir F.R., Alsammak A.N.B. Improving Power Quality in Distribution Systems Using UPQC: An Overview. *Journal Européen Des Systèmes Automatisés*, 2024, vol. 57, no. 2, pp. 311-322. doi: <https://doi.org/10.18280/jesa.570201>.
5. Manohara M., Muthukaruppasamy S., Dharmaprakash R., Sendilkumar S., Dattatreya Bharadwaj D., Parimalasundar E. Power quality enhancement of grid-integrated solar photovoltaic system with unified power quality conditioner. *Electrical Engineering & Electromechanics*, 2024, no. 6, pp. 44-48. doi: <https://doi.org/10.20998/2074-272X.2024.6.06>.
6. Qasim A.Y., Tahir F.R., Alsammak A.N.B. Utilizing UPQC-Based PAC-SRF Techniques to Mitigate Power Quality Issues under Non-Linear and Unbalanced Loads. *Journal Européen Des Systèmes Automatisés*, 2023, vol. 56, no. 5, pp. 823-831. doi: <https://doi.org/10.18280/jesa.560513>.
7. Kalyan K., Rao M.S., Gawre S. Improvement of Power Quality Using Series Active Power Filter (SAPF). *2020 IEEE International Students' Conference on Electrical, Electronics and Computer Science (SCEECS)*, 2020, pp. 1-5. doi: <https://doi.org/10.1109/SCEECS48394.2020.151>.
8. Kim Y.S., Kim J.S., Ko S.H. Three-phase three-wire series active power filter, which compensates for harmonics and reactive power. *IEE Proceedings - Electric Power Applications*, 2004, vol. 151, no. 3, pp. 276-282. doi: <https://doi.org/10.1049/ip-epa:20040208>.
9. Muthukaruppasamy S., Dharmaprakash R., Sendilkumar S., Parimalasundar E. Enhancing off-grid wind energy systems with controlled inverter integration for improved power quality. *Electrical Engineering & Electromechanics*, 2024, no. 5, pp. 41-47. doi: <https://doi.org/10.20998/2074-272X.2024.5.06>.
10. Benazza B., Ouadi H. Backstepping Control of Three-Phase Multilevel Series Active Power Filter. *2020 International Conference on Electrical and Information Technologies (ICEIT)*, 2020, pp. 1-6. doi: <https://doi.org/10.1109/ICEIT48248.2020.9113178>.
11. Bousnoubra C., Djeghader Y., Belila H. Contribution of using a photovoltaic unified power quality conditioner in power quality improvement. *Electrical Engineering & Electromechanics*, 2024, no. 4, pp. 42-47. doi: <https://doi.org/10.20998/2074-272X.2024.4.05>.
12. Venkatraman K., Selvan M.P., Moorthi S. Performance of Series Active Filter in low voltage distribution system with non linear loads. *2011 Annual IEEE India Conference*, 2011, pp. 1-6. doi: <https://doi.org/10.1109/INDCON.2011.6139548>.
13. Mekri F., Machmoum M., Aït-Ahmed N., Mazari B. A comparative study of voltage controllers for series active power filter. *Electric Power Systems Research*, 2010, vol. 80, no. 6, pp. 615-626. doi: <https://doi.org/10.1016/j.epsr.2009.10.025>.
14. Pazhanimuthu C., Ramesh S. Grid integration of renewable energy sources (RES) for power quality improvement using adaptive fuzzy logic controller based series hybrid active power filter (SHAPF). *Journal of Intelligent & Fuzzy Systems*, 2018, vol. 35, no. 1, pp. 749-766. doi: <https://doi.org/10.3233/JIFS-171236>.
15. Das S.R., Ray P.K., Mohanty A. Fuzzy Sliding Mode Based Series Hybrid Active Power Filter for Power Quality Enhancement. *Advances in Fuzzy Systems*, 2018, pp. 1-8. doi: <https://doi.org/10.1155/2018/1309518>.
16. Nakade V., Patil S. Implementation of Power Quality Enhancement using Hybrid Series Active Filter. *2019 International Conference on Communication and Electronics Systems (ICES)*, pp. 238-241. doi: <https://doi.org/10.1109/ICES45898.2019.9002378>.
17. Toumi T., Allali A., Mefstouhi A., Abdelkhalek O., Benabdelkader A., Denai M. Robust control of series active power filters for power quality enhancement in distribution grids: Simulation and experimental

validation. *ISA Transactions*, 2020, vol. 107, pp. 350-359. doi: <https://doi.org/10.1016/j.isatra.2020.07.024>.

18. Mishra K.K., Gupta R. Impedance Factor based Control Strategy for Series Active Power Filter in Distribution System. *IECON 2020 The 46th Annual Conference of the IEEE Industrial Electronics Society*, pp. 2987-2992. doi: <https://doi.org/10.1109/IECON43393.2020.9255093>.

19. Pazhanimuthu C., Baranilingesan I., Karthick A. An improved control algorithm for Series Hybrid Active Power Filter based on SOGI-PLL under dynamic load conditions. *Solid State Communications*, 2021, vol. 333, art. no. 114357. doi: <https://doi.org/10.1016/j.ssc.2021.114357>.

20. Cholamuthu P., Irusappan B., Paramasivam S.K., Ramu S.K., Muthusamy S., Panchal H., Nuvvula R.S.S., Kumar P.P., Khan B. A Grid-Connected Solar PV/Wind Turbine Based Hybrid Energy System Using ANFIS Controller for Hybrid Series Active Power Filter to Improve the Power Quality. *International Transactions on Electrical Energy Systems*, 2022, pp. 1-14. doi: <https://doi.org/10.1155/2022/9374638>.

21. Rustemli S., Satici M.A., Şahin G., Van Sark W. Investigation of harmonics analysis power system due to non-linear loads on the electrical energy quality results. *Energy Reports*, 2023, vol. 10, pp. 4704-4732. doi: <https://doi.org/10.1016/j.egyr.2023.11.034>.

22. Sathish Babu P., Balasundar C., Sundarabalan C.K. ANFIS controlled fuel cell powered series active filter for voltage waveform augmentation in the distribution grid. *E-Prime - Advances in Electrical Engineering, Electronics and Energy*, 2024, vol. 7, art. no. 100425. doi: <https://doi.org/10.1016/j.prime.2024.100425>.

23. Rafiq Nazer M.N., Noorwali A., Tajuddin M.F.N., Khan M.Z., Ahmad Tazally M.A.I., Ahmed J., Babu T.S., Ghazali N.H., Chakraborty C., Manoj Kumar N. Scenario-Based Investigation on the Effect of Partial Shading Condition Patterns for Different Static Solar Photovoltaic Array Configurations. *IEEE Access*, 2021, vol. 9, pp. 116050-116072. doi: <https://doi.org/10.1109/ACCESS.2021.3105045>.

24. Zhuang Y., Liu F., Huang Y., Zhang X., Zha X. A Voltage-Balancer-Based Cascaded DC-DC Converter With a Novel Power Feedforward Control for the Medium-Voltage DC Grid Interface of Photovoltaic Systems. *IEEE Access*, 2019, vol. 7, pp. 178094-178107. doi: <https://doi.org/10.1109/ACCESS.2019.2959040>.

25. Aravind S., Vinatha U., Jayasankar V.N. Wind-solar grid connected renewable energy system with series active self tuning filter. *2016 International Conference on Electrical, Electronics, and Optimization Techniques (ICEEOT)*, pp. 1944-1948. doi: <https://doi.org/10.1109/ICEEOT.2016.7755028>.

26. Meftouh A., Abdelkhalik O., Allali A., Abdelkader A.B., Toumi T. PV integrated series active filter for sag voltage and harmonic compensation. *International Journal of Power Electronics and Drive Systems*, 2019, vol. 10, no. 3, pp. 1255-1262. doi: <https://doi.org/10.11591/ijpeds.v10.i3.pp1255-1262>.

27. Guergah M., Nebti K., Rezzoui S.E., Benalla H., Ould-Abdeslam D. Power quality enhancement using active power filter five-level cascade H-bridge under unbalanced and distorted grid. *Electrical Engineering & Electromechanics*, 2023, no. 1, pp. 20-24. doi: <https://doi.org/10.20998/2074-272X.2023.1.03>.

28. Salmerón Revuelta P., Pérez Litrán S., Prieto Thomas J. Combined Shunt and Series Active Power Filters. *Active Power Line Conditioners*, 2016, pp. 231-284. doi: <https://doi.org/10.1016/B978-0-12-803216-9.00007-9>.

29. El Ghaly A., Tarnini M., Al Barakeh Z., Chahine K. Compensating voltage waveform distortions using a practical topology of series active power filters. *Results in Engineering*, 2024, vol. 22, art. no. 102032. doi: <https://doi.org/10.1016/j.rineng.2024.102032>.

30. Nguyen D., Lehman B. An Adaptive Solar Photovoltaic Array Using Model-Based Reconfiguration Algorithm. *IEEE Transactions on Industrial Electronics*, 2008, vol. 55, no. 7, pp. 2644-2654. doi: <https://doi.org/10.1109/TIE.2008.924169>.

31. Mimouni A., Laribi S., Sebaa M., Allaoui T., Bengharbi A.A. Fault diagnosis of power converters in a grid connected photovoltaic system using artificial neural networks. *Electrical Engineering & Electromechanics*, 2023, no. 1, pp. 25-30. doi: <https://doi.org/10.20998/2074-272X.2023.1.04>.

32. Mishra S., Ziar H., Isabella O., Zeman M. Selection Map for PV Module Installation Based on Shading Tolerability and Temperature Coefficient. *IEEE Journal of Photovoltaics*, 2019, vol. 9, no. 3, pp. 872-880. doi: <https://doi.org/10.1109/JPHOTOV.2019.2900695>.

33. Chaib H., Hassaine S., Mihoub Y., Moreau S. Intelligent power control strategy based on self-tuning fuzzy MPPT for grid-connected

*How to cite this article:*

Anwer B.M., Alsammak A.N. An integrated series active power filter combined with a PV-battery system based on a fuzzy logic controller to enhance power quality for various linear and non-linear loads. *Electrical Engineering & Electromechanics*, 2026, no. 1, pp. 51-62. doi: <https://doi.org/10.20998/2074-272X.2026.1.07>

hybrid system. *Electrical Engineering & Electromechanics*, 2025, no. 3, pp. 23-30. doi: <https://doi.org/10.20998/2074-272X.2025.3.04>.

34. Hessad M.A., Bouchama Z., Benagoune S., Behih K. Cascade sliding mode maximum power point tracking controller for photovoltaic systems. *Electrical Engineering & Electromechanics*, 2023, no. 1, pp. 51-56. doi: <https://doi.org/10.20998/2074-272X.2023.1.07>.

35. Shahir F.M., Aberoumandazar M., Babaei E. High Gain DC-DC Boost Converter Applied in Hybrid System of Photovoltaic and Battery. *2021 International Symposium on Devices, Circuits and Systems (ISDCS)*, 2021, pp. 1-4. doi: <https://doi.org/10.1109/ISDCS52006.2021.9397922>.

36. Surya P.P., Irawan D., Zuhri M. Review and comparison Of DC-DC converters for maximum power point tracking system in standalone photovoltaic (PV) module. *2017 International Conference on Advanced Mechatronics, Intelligent Manufacture, and Industrial Automation (ICAMIMIA)*, 2017, pp. 242-247. doi: <https://doi.org/10.1109/ICAMIMIA.2017.8387595>.

37. Latreche K., Taleb R., Bentaallah A., Toubal Maamar A.E., Helaimi M., Chabni F. Design and experimental implementation of voltage control scheme using the coefficient diagram method based PID controller for two-level boost converter with photovoltaic system. *Electrical Engineering & Electromechanics*, 2024, no. 1, pp. 3-9. doi: <https://doi.org/10.20998/2074-272X.2024.1.01>.

38. Farswan R.S., Datta A., Kamble G., Fernandes B.G. A low leakage transformer-less 3-level DC-DC boost converter for transformer-less PV inverters. *2015 17th European Conference on Power Electronics and Applications (EPE'15 ECCE-Europe)*, 2015, pp. 1-10. doi: <https://doi.org/10.1109/EPE.2015.7309321>.

39. Bonfiglio A., Brignone M., Delfino F., Procopio R. Optimal Control and Operation of Grid-Connected Photovoltaic Production Units for Voltage Support in Medium-Voltage Networks. *IEEE Transactions on Sustainable Energy*, 2014, vol. 5, no. 1, pp. 254-263. doi: <https://doi.org/10.1109/TSTE.2013.2280811>.

40. Yang T., Mok K.-T., Ho S.-S., Tan S.-C., Lee C.-K., Hui R.S.Y. Use of Integrated Photovoltaic-Electric Spring System as a Power Balancer in Power Distribution Networks. *IEEE Transactions on Power Electronics*, 2019, vol. 34, no. 6, pp. 5312-5324. doi: <https://doi.org/10.1109/TPEL.2018.2867573>.

41. Parimalasundar E., Kumar N.M.G., Geetha P., Suresh K. Performance investigation of modular multilevel inverter topologies for photovoltaic applications with minimal switches. *Electrical Engineering & Electromechanics*, 2022, no. 6, pp. 28-34. doi: <https://doi.org/10.20998/2074-272X.2022.6.05>.

42. Huang X., Wang H., Guo L., Ju C., Liu R., Meng S., Wang Y., Xu H. Large-scale photovoltaic generation system connected to HVDC grid with centralized high voltage and high power DC/DC converter. *2017 20th International Conference on Electrical Machines and Systems (ICEMS)*, 2017, pp. 1-6. doi: <https://doi.org/10.1109/ICEMS.2017.8056289>.

43. Ayat Y., Badoud A.E., Mekhilef S., Gassab S. Energy management based on a fuzzy controller of a photovoltaic/fuel cell/Li-ion battery/supercapacitor for unpredictable, fluctuating, high-dynamic three-phase AC load. *Electrical Engineering & Electromechanics*, 2023, no. 3, pp. 66-75. doi: <https://doi.org/10.20998/2074-272X.2023.3.10>.

44. Adiche S., Larbi M., Toumi D. Optimizing voltage control in AC microgrid systems with fuzzy logic strategies and performance assessment. *Electrical Engineering & Electromechanics*, 2025, no. 3, pp. 11-17. doi: <https://doi.org/10.20998/2074-272X.2025.3.02>.

45. Mohammed H.A., Alsammak A.N.B. An Intelligent Hybrid Control System using ANFIS-Optimization for Scalar Control of an Induction Motor. *Journal Européen Des Systèmes Automatisés*, 2023, vol. 56, no. 5, pp. 857-862. doi: <https://doi.org/10.18280/jesa.560516>.

46. Zerzouri N., Ben Si Ali N., Benalia N. A maximum power point tracking of a photovoltaic system connected to a three-phase grid using a variable step size perturb and observe algorithm. *Electrical Engineering & Electromechanics*, 2023, no. 5, pp. 37-46. doi: <https://doi.org/10.20998/2074-272X.2023.5.06>.

Received 29.07.2025

Accepted 25.09.2025

Published 02.01.2026

B.M. Anwer<sup>1</sup>, MSc, Assistant Lecturer, PhD Student,

A.N. Alsammak<sup>1</sup>, PhD, Professor,

<sup>1</sup>Electrical Engineering Department,

College of Engineering, University of Mosul, Iraq,

e-mail: ahmed\_alsammak@uomosul.edu.iq (Corresponding Author)