

UDC [622.414.32: 622.012.2]. 003.12

ESTIMATION AND USE MATERIALS OF THE AIRILY-DEPRESSED SURVEYS ON THE COAL MINES OF UKRAINE**¹Bunko T.V., ²Shyshov M.V., ²Myroshnychenko V.V., ¹Kokoulin I.Ye., ¹Dudnyk M.M.**¹*Institute of Geotechnical Mechanics named by N. Poliakov of National Academy of Sciences of Ukraine, ²DTEK ENERGO***ОЦІНКА І ВИКОРИСТАННЯ МАТЕРІАЛІВ ПОВІТРЯНО-ДЕПРЕСІЙНИХ ЗЙОМОК НА ВУГІЛЬНИХ ШАХТАХ УКРАЇНИ****¹Бунько Т.В., ²Шишов М.В., ²Мірошніченко В.В., ¹Кокоулін І.Є., ¹Дудник М.М.**¹*Інститут геотехнічної механіки ім. М.С. Полякова НАН України, ²ДТЕК ЕНЕРГО***ОЦЕНКА И ИСПОЛЬЗОВАНИЕ МАТЕРИАЛОВ ВОЗДУШНО-ДЕПРЕССИОННЫХ СЪЕМОК НА УГОЛЬНЫХ ШАХТАХ УКРАИНЫ****¹Бунько Т.В., ²Шишов М.В., ²Мирошніченко В.В., ¹Кокоулін І.Є., ¹Дудник М.М.**¹*Інститут геотехнічної механіки ім. Н.С. Полякова НАН України, ²ДТЕК ЕНЕРГО*

Annotation. In the conditions of intensive development of mine works the vent networks of coal mines become more prolonged and ramified, the task of correct prognostication of their ventilation is complicated as a result. The calculations of air-distribution in a mine vent network (MVN) are impossible without the use of the modern computing engineering and creation of the MVN mathematical model for conducting of vent calculations. Materials of the airily-depressed surveys (ADS) are mortgaged in basis of it, periodically conducted on mines. The metodological resources and hardwares of receipt, control and actualization of the ADS results needs in perfection. Questions which do not answer to the modern ADS in the questions of control of the coal mines aerological state are certain. The methods of structural (estimations of adequacy of the built calculation chart to its real analogue (within the limits of the information, represented by a calculation chart, and own experience and perception of the real object, by an user)) and parametrical (estimations and minimizations of rejections of values for the networks, analysed on adequacy, charges of air and depressions) authentication of mine vent network are developed. It is suggested to replace the out-of-date devices of control of aerodynamic parameters more modern, developed by Institute of geotechnical mechanics named by N. Polyakov National academy of sciences of Ukraine: by the portable mine anemometer APR-2, differential micromanometer MDR-6, transformer of difference of pressure PRD-1. It is offered new approach to actualization of information, consisting in komplexing of measurings by stationary and mobile devices of control. Methods of structural - parametrical authentication and the devices of control of aerodynamic parameters of a new technical level are offered first. Will allow the use of the offered methods and hardwares of treatment of the ADS results to improve quality ца obtained aerodynamic information.

Keywords: mine vent network, airily-depressed survey, aerodynamic parameters, actualization of information, control devices, adequacy.

Introduction. In the conditions of intensive development of mining works, the ventilation networks of coal mines become more extensive and branched, as a result of which the complication the task of correct forecasting of their ventilation become complicated. Calculations of air-distribution in the mine ventilation network (MVN) is not possible without the use of modern computer technique, and so - the creation of a mathematical model MVN for ventilation calculations.

For creation of correct mathematical model of MVN it is necessary to solve several interconnection tasks:

a) create a calculation scheme of the MVN, that is to draw on paper in conditional form an aggregate of mine workings (in the future we shall call them the branches

of the network), ventilation constructions and main fans (MF);

b) to determine on it the places of the necessary measurements (basis) aero- (if necessary – and gas-dynamic) parameters, the totality of which will provide an exhaustive

representation about aerodynamic state of the MVN;

c) to carry out an experimental measurements of aerodynamic parameters in mining workings and their geometric parameters;

d) combining the results of works a) – c), to create the mathematical model of MVN;

e) to assess the structural and parametric adequacy of the received mathematical model of MVN and its real analog, which in general is necessary, and its degree – sufficient condition for use of the obtained mathematical model in the calculations of air-distribution in the MVN, and in the future – and during the MVN control in normal and emergency conditions.

Works of items a) – c) in production conditions are carried out in the process of conducting of airily-depressed surveys (ADS) by the units of the State paramilitary mine rescue service (SPMRS), and in the regulated period between their carrying out at the mine (three years) – employees of the district of ventilation and safety technique (VST) of the mine. The results obtained require further processing, which shown by methods of structural and parametric identification, a large part of which was created at the Institute of Geotechnical Mechanics named by N. Poljakov of National Academy of Sciences of Ukraine (IGTM NAS of Ukraine). Attaining during the creation of mathematical model of MVN the necessary level of its adequacy to the real ventilation network, can be obtained an information base for control by mine ventilation.

Carrying out of the ADS of coal mine is an integral part provision of the life of mine. Therefore, to regulate its conducting exists and periodically updated the relevant normative document; last him version is the Guidance normative document of the Ministry of Fuel and Energy of Ukraine "Depression and gas surveys in coal mines. Methods of conducting. Instruction". In fact, it regulates only methods of the works of item c), leaving the decision of the previous of items a) – c) in production conditions are carried out in the process items a) – b) and the subsequent items d) – e) works at the discretion of the management and personnel of the mine.

Therefore, there is now many approaches to the creation of the mathematical model of MVN, and the program realization of the decision of separate its tasks are carried out by several software complexes developed IGTM NAS of Ukraine, Naukovo-Doslidnyi Instytut Hirnychoriatuvalnoi Spravy ta Pozhezhnoi Bezpeky «Respirator», Donetsk National Technical University and others.

The general regulated approach to the creation of the mathematical model of MVN does not exist at all, and even a simplified document of 2005 year, which partially implements the decision of these problems, is outdated and not tells modern realities. Therefore, the purpose of the publication is to prepare a new version of the document, which would regulate the main stages of the creation of the mathematical model of MVN and took into account changes that have recently occurred in

methodological approaches to obtaining information concerning the aerodynamic state of the MVN, and the characterization of the methods of solution scientific and practical tasks which arise in this case.

Research strategy. The research was based on the fact that the general approach to the use of results of the ADS remain unchanged, and correct decision of separate her tasks. Therefore, the research is organized as follows (Fig. 1).

From Figure 1 it can be seen that, as a result of the definition of issues missing in the old methods of conducting and processing the materials of the ADS, 12 major allocated, need as the improvement of existing methods (blocks 1, 5, 6, 7, 11, 12), and the search of new solutions (remaining blocks).

Results and discussion.

1. Up to the present time formation of the calculation schemes of ventilation conducted manual, and the graphic editor, in the prevalence number of cases, uses for visualization (building an electronic version of the scheme based on the drawn), and improvement of perception. In addition, the distinction of the ventilation system is that it is not a collection of only really existing workings, but also contains uncertain areas (parts of the produced lava space, the zone of collapse).

Many problems automation creation of calculation scheme remained out of sight, or were not yet resolved as a result of complexity (construction of a volumetric scheme, rotation of the scheme around coordinates axes, allocation part of the scheme by separating the graph of the network, etc.). But even manually build a calculation scheme is quite difficult.

The scheme which is used as the primary for its construction, is a surveyor two-line mine scheme. It gives an impression, if not a spatial representation of mines workings, then at least about the shape projection of the horizon or panel on the horizontal plane. And even with the real, in the adopted scale, the length of workings, and their mutual arrangement.

But this scheme has significant disadvantages, in particular: presence the number of sites whose aerodynamic parameters can not be determined in consequent of inaccessibility for measurements; the presence of parts that do not participate in ventilation (deadlocks, workings of technological destination, where in consequence of peoples the amount of air does not require regular control, etc.).

On the surveyor scheme they are not present, but certain participation in the process of ventilation they are assume. Therefore the construction of calculation scheme is not a technical work, but an art, which is impossible to completely formalize.

As a result of the inherent to the compiler peculiarities of thinking scheme main's be universal and will require of some conditional simplifications.

For facilitate of such actions are used at the stage construction of a calculation scheme two sets of criteria and methods, namely: method of the assessment adequacy of the underlying design scheme its real analogy (in the confines of information provided by the calculation scheme, and own perception about the real object by the consumer) and methods of structural identification of MVN.

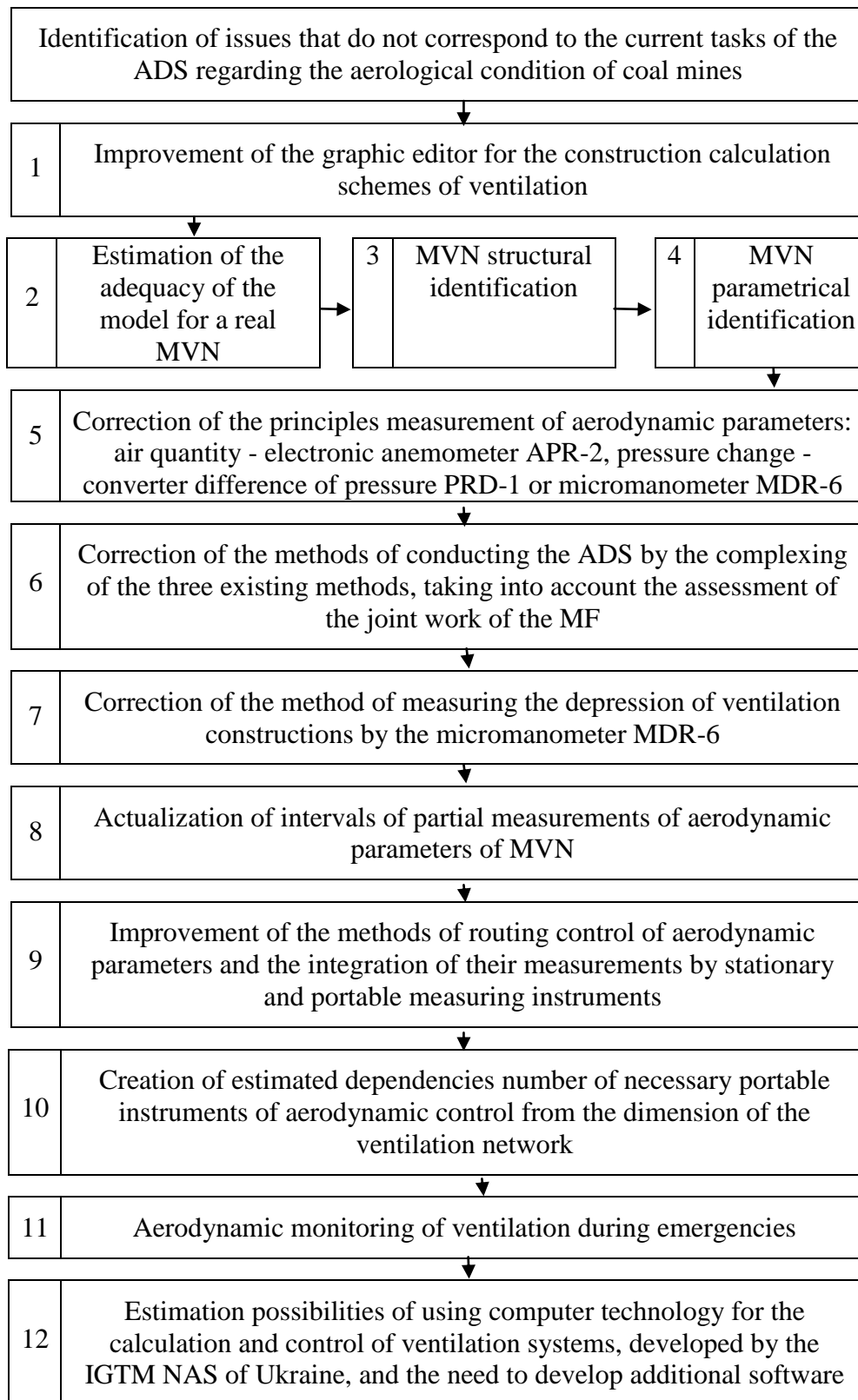

Figure 1 - Structural scheme perfection of conducting and processing results of ADS

For facilitate of such actions are used at the stage construction of a calculation scheme two sets of criteria and methods, namely: method of the assessment adequacy of the underlying design scheme its real analogy (in the confines of information

provided by the calculation scheme, and own perception about the real object by the consumer) and methods of structural identification of MVN.

2. Method for assessing of structural adequacy are described in detail in [1]. Shortly an aggregate criteria of structural adequacy can be characterized as follows: how much, in qualitative and quantitative terms, the real MVN coincide with the modeling analogue (number, relative position of elements, their connection, etc.), and on an accepted scale, if there is a need for it, - as soon as possible the geometric characteristics of these are relatively accurately displayed.

If networks are considered as structurally adequate with a given degree of accuracy - it is necessary to check their parametric adequacy by the method given in the source [1]. Since the basic aerodynamic parameters elements of MVN are debit of air and depression of workings, parametric criteria adequacy is focused on minimizing of deviations of values for networks that analysing on adequacy, precisely for these parameters.

The task of structural identification of the MVN with indeterminate zones lies in establishing the correspondence between the elements of the real MVN (which assign by the graph $G(X,U)$, where X – quantity of nodes, dimension of which is m , U – quantity of branches, dimension of which is n) and its MM (which assign by the graph $G_M(X_M,U_M)$, where X_M , U_M – quantity of modeling nodes and branches with dimension m and n respectively) by way of identification of basic aerodynamic connections between its elements and definition a plurality of main and additional air users.

Method decision task of structural identification for the case of MVN with non-defined structure, is shown on Figure 2.

Thus, the task of structural identification is to maximize the small of deviation in any of the nodes of real and simulated networks, not exceeded the value of the criterion of adequacy associated with the measurements of air debit $ad(G_M^{Q(i,j)})$ with condition $min\{dim G_M^{Q(i,j)}\}$ - minimization of dimensional and reciprocal criteria of network. $Q(i,j)$ – debit of air in the working (i,j) , m^3/s .

The task of parametrical identification of the MVN with indefinite aerodynamic parameters are to assess of probability of the air values of air flow at all network areas and pressure in all nodes of the network due to changes to only some of these variables.

As a result of solving the problem by the calculated or experimental data, determined the values of aerodynamic resistances, distribution of depressions and the air debits in all MVN workings, which satisfying the network laws.

After completion of this stage it is necessary to solve a problem of parametrical identification.

The mathematical formulation of the task identifying of the aerodynamic parameters of the MVN [1] consists in minimizing of functional:

$$F = \sum_{(i,j) \in U} \left[\frac{1}{(\delta_{(i,j)}^q)^2} (Q(i,j) - Q^*(i,j))^2 + \frac{1}{(\delta_{(i,j)}^h)^2} (H(i,j) - H^*(i,j))^2 \right] \rightarrow \min \quad (1)$$

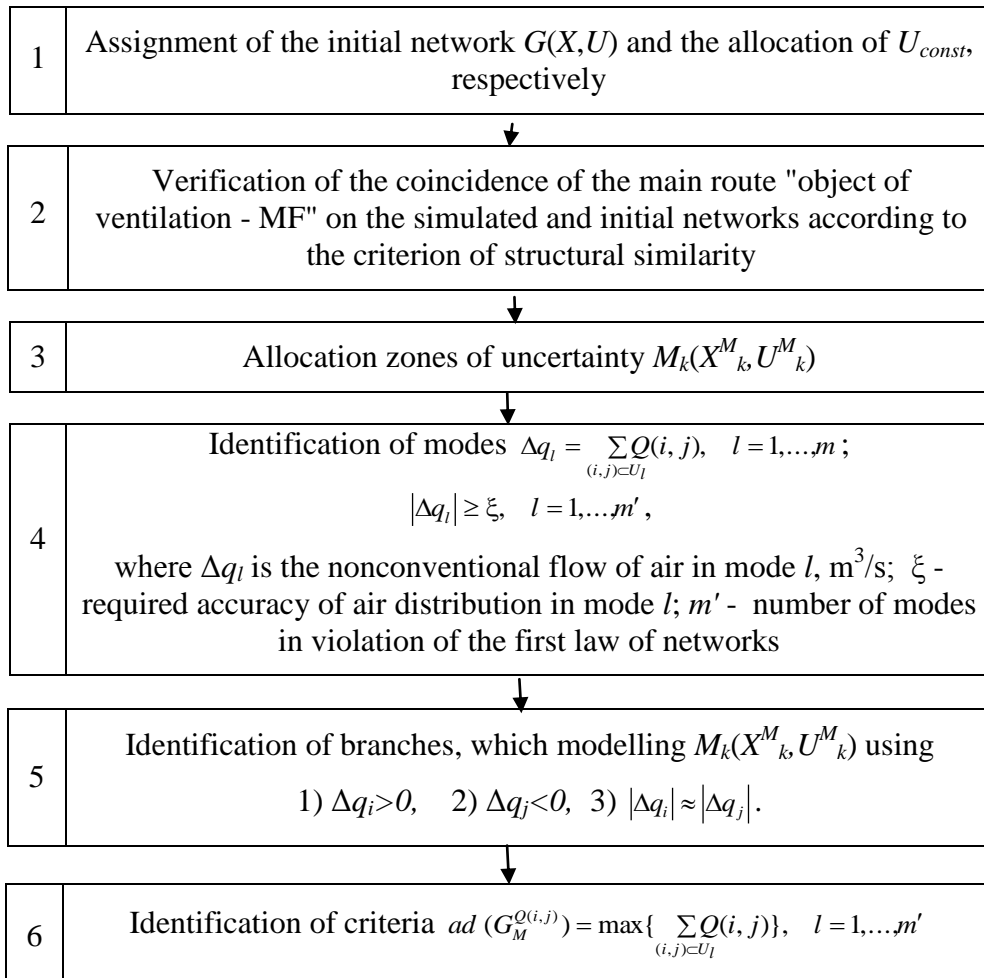

Figure 2 - Algorithm for structural identification of MVN

with restrictions

$$\sum_{(i,j) \in U_l} Q(i,j) = 0, \quad l = 1, \dots, m \tag{2}$$

$$\sum_{(i,j) \in U_\mu} ((\text{sign} Q(i,j)) R(i,j) Q^2(i,j) \pm h_e) - \sum_{(i,j) \in (U_\mu \cap U_b)} H(i,j) = 0, \quad \mu = 1, \dots, m - n + 1 \tag{3}$$

$$H(i,j) = a(i,j) - b(i,j) Q^2(i,j), \quad (i,j) \in U_b \tag{4}$$

$$R(i,j) = \frac{\alpha(i,j) \cdot P(i,j) \cdot L(i,j)}{[S(i,j)]^3}, \quad (i,j) \in U \setminus U_b \tag{5}$$

$$Q(i,j) = S(i,j) \cdot V(i,j), \quad (i,j) \in U \setminus U_b \tag{6}$$

$$R^{\min}(i,j) \leq R(i,j) \leq R^{\max}(i,j), \quad (i,j) \in U \setminus U_b \tag{7}$$

$$Q^{\min}(i,j) \leq Q(i,j) \leq Q^{\max}(i,j), \quad (i,j) \in U \tag{8}$$

$$H^{\min}(i,j) \leq H(i,j) \leq H^{\max}(i,j), \quad (i,j) \in U \tag{9}$$

where U – a quantity of branches of MVN; U_l – a quantity of branches incident to the first node; U_μ – a quantity of branches that belong to the μ independent contour; U_b is the quantity of MF; h_e is the value of the natural draft acting in μ independent contour; $L(i, j)$ – length of working, m; $S(i, j)$ is the area cross-section of the working, m^2 ; $Q(i, j)$, $Q^{min}(i, j)$, $Q^{max}(i, j)$ – respectively debit of air in the working, its minimum and maximum permissible values, m^3/s ; $H(i, j)$, $H^{min}(i, j)$, $H^{max}(i, j)$ respectively depression of working, its minimum and maximum permissible values, Pa; $R(i, j)$, $R^{min}(i, j)$, $R^{max}(i, j)$ – respectively resistance of the working, its minimum and maximum permissible values, $Pa \cdot s^2/m^6$; $\alpha(i, j)$ – coefficient of resistance of the working, $Pa \cdot s^2/m^2$; $\delta^q(i, j)$, $\delta^h(i, j)$ – respectively the value of the probability of the problem of quantities $Q(i, j)$, $H(i, j)$ in working. Its dimensions are m^3/s and Pa respectively; $a(i, j)$, $b(i, j)$ – coefficients of the approximation of the characteristics of the MF, Pa and $Pa \cdot s^2/m^6$ respectively; $Q^*(i, j)$, $H^*(i, j)$ – measured values of air debit and depression of mining workings respectively; h_e – depression of natural draught; $V(i, j)$ – rate of air motion in working, m/s; $P(i, j)$ – perimeter of working, m.

Investigation of necessary and sufficient conditions for the existence of a functional minimum (1) under restrictions (2) and (3) showed that the function of the goal (1) is protuberant, because is the sum of protuberant functions of the form

$$\frac{1}{(\delta_{(i,j)}^q)^2} (Q(i, j) - Q^*(i, j))^2 \quad \text{and} \quad \frac{1}{(\delta_{(i,j)}^h)^2} (H(i, j) - H^*(i, j))^2,$$

i.e. the function has a single extremum.

Formulation of the task of identifying the aerodynamic parameters of the MVN in conditions incomplete and insufficiently reliable information should be supplemented by bilateral constraints on variables (6) – (9).

In this case it is assumed that according to the calculated formulas and experimental dependences of the change in resistance, you can get an upper bound and the lower boundary of the change of the aerodynamic parameters of the MVN.

In the formulation of the problem $P(i, j)$ – quality characteristic state of working is taken into account for the first time. For this the quantity of workings is divided into 3 groups depending the condition of working: I – well (workings without significant deformation); II – satisfactory (working with partially deformed fastening); III – bad (accidentally deformed workings, or with a significant amount of breed and equipment). A quantitative estimate of the resistance of these workings will be determined by the formula (5). A more detailed qualitative description of workings and taking into account it during calculation of the MVN is described in [2]. The main stages of the method identifying of uncertain aerodynamic parameters of the CFM are as follows (Fig. 3).

Thus, the tasks of blocks 2 – 4 (Fig. 1), which have not been used before, during the processing of the results of the airily-depressed surveys, are solved.

3. Measurement of aerodynamic parameters was carried out to the present time by equipment of obsolete technical level – anemometers ASO-3, MS-13 and micromanometer with a rubber tube.

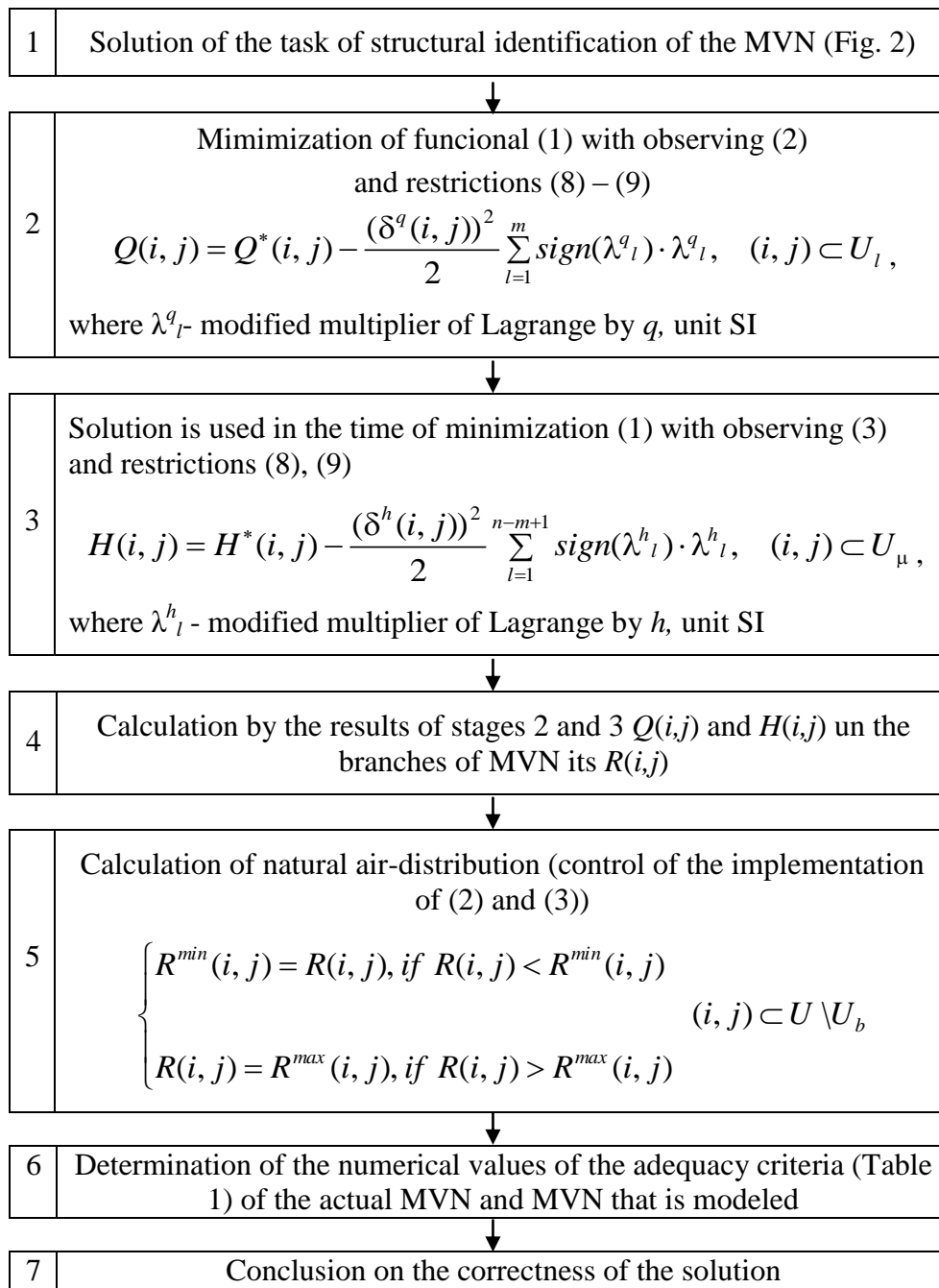
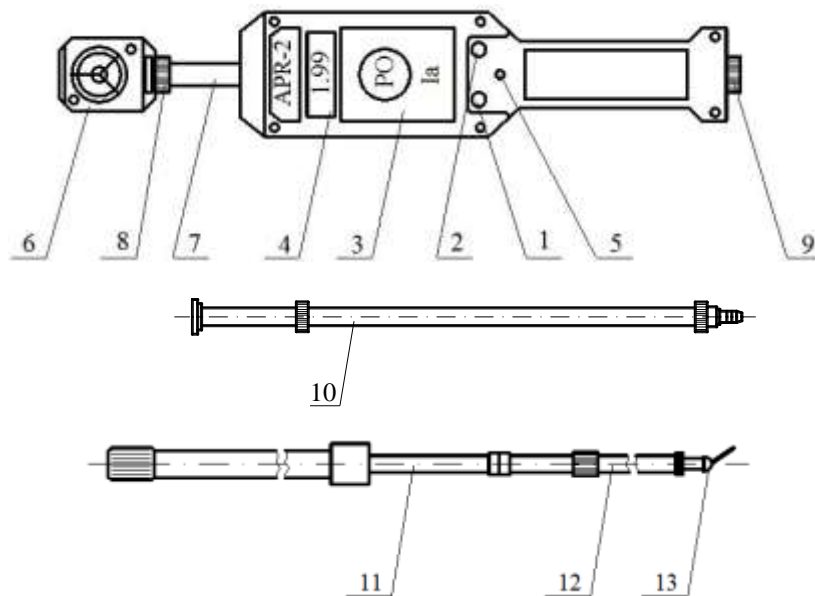

Figure 3 - Algorithm of parametrical identification of the MVN

In addition to the complexity of using this base did not provide sufficient accuracy of measurements.

The results forcedly wrote in the digital expression of units of the scale of device with the subsequent conversion into physical units. They replaced the new domestic development devices. The main certificated means of control the role of speed (and, then, the debit) of air in mine workings of mines not only Ukraine, as well as CIS countries, is a anemometer portable mine APR-2 [1], which was developed by IGTM NAS of Ukraine specially for mines, and the serial issue of which was mastered in 2001 (Fig. 4).



1 – switching button with fixation; 2 – control button without fixation; 3 – measuring bloc;
 4 – indicator; 5 – output of the control point; 6 – primary converter; 7 – telescopic lengthening;
 8 – union nut; 9 – screw; 10 – one-way bar lengthening; 11, 12 – telescopic sections of multi-link
 lengthening; 13 – hinge

Figure 4 - Modern anemometer APR-2 complete with one-lane 0.3 m and iterative 3 m extending

Our institute has released three modifications of APR-2, which greatly improved its technical and metrological characteristics. New solutions are protected by Ukrainian patents No 102727 and No 108532. The winged anemometer APR-2 differs from analogous devices for this purpose with high reliability, long and convenient operation in mine conditions, as well as better accuracy of metrological characteristics in a wide range of measurements from 0.15 to 20.0 m/s with a maximum speed of 42 m/s and the definition of air flow in mining structures with a flow cross section from 1 to 50 m². Thus, since 1992, an anemometer APR-2, which replaced the morally and physically obsolete ASO-3 and MS-13 anemometers, remains the main modern means of measuring the speed and flow of air in mines of Ukraine and CIS countries.

For accurate measurement of pressure difference and depression of extended objects as well relative humidity of air and a temperature in the workings of coal mines a differential mine micromanometer MDR-6 [1] is used (Fig. 5).

This is the latest development of IGTM NAS of Ukraine. On the way of measuring the difference in air pressure we obtained Patents of Ukraine No 102288 and No 102288. Since 2018, we have mastered the release of a device that differs from the best world analogues of this purpose with more accurate characteristics of pressure measurement. The State Center for Certification and Standardization of Ukraine acknowledged that the micromanometer MDR-6 measuring the difference in pressure in the range from 0 to 6000 Pa with an error of not more than $\pm(2 + 0.002dP)$, where dP is the measured pressure drop.

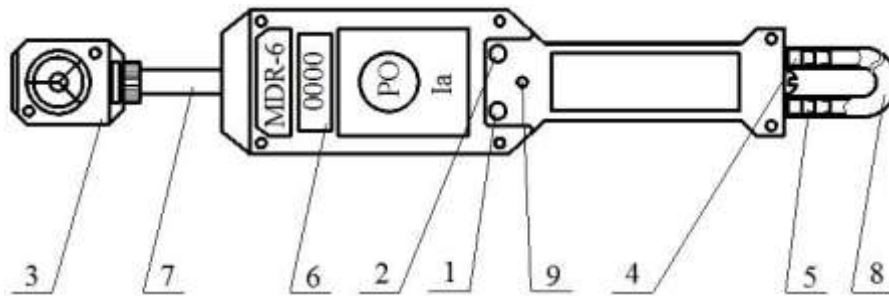

1 – button to switch to the mode of measurement of pressure differences; 2 – the power button in the mode measurements of temperature and air humidity; 3 – remote sensor of temperature and humidity of the environment; 4 and 5 – pressure pipes; 6 – digital indicator; 7 – telescopic lengthening; 8 – preventive tube; 9 – checkpoint

Figure 5 - Micromanometer differential mine MDR-6

The devices are equipped with processors that convert the performance of the devices directly in the system unit of measurement with the display on the device. Used one more development of the IGTМ NAS of Ukraine – the converter of pressure difference PRD-1, earlier model of micromanometer MDR-6, – in combination with APR-2 [3] (Fig. 6, 7). The converter allows to measure the pressure drop at the ventilation structures (Fig. 8) and in the degassing pipelines (Fig. 9).

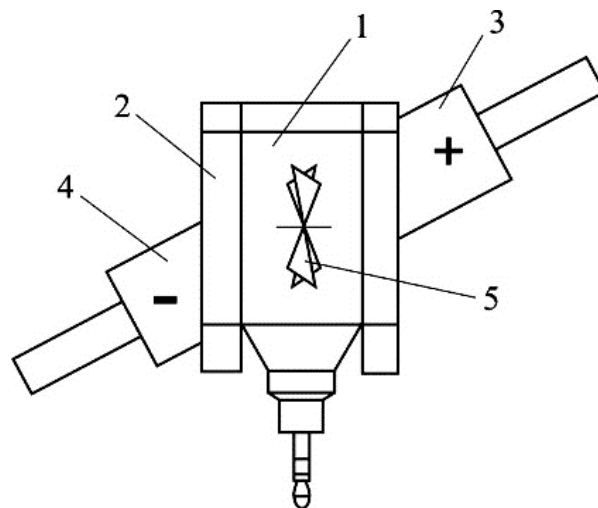

1 – the primary converter of the air velocity of the anemometer APR-2; 2 – lid; 3 – high-pressure nozzle; 4 – low pressure nozzle; 5 – impeller

Figure 6 - Primary pressure difference converter

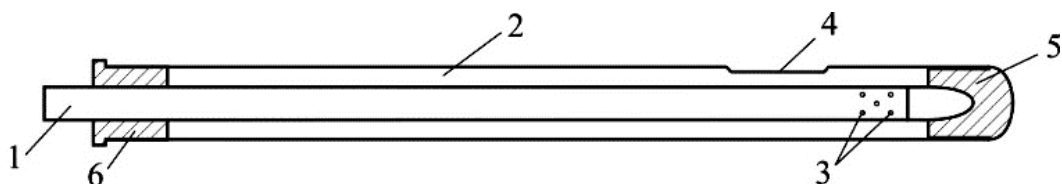

1 – measuring tube; 2 – protective tube; 3 – measuring holes of the measuring tube; 4 – the entrance hole of the protective tube; 5 - stopper; 6 – plug-stopper

Figure 7 - Static probe to aerodynamic differential pressure converter

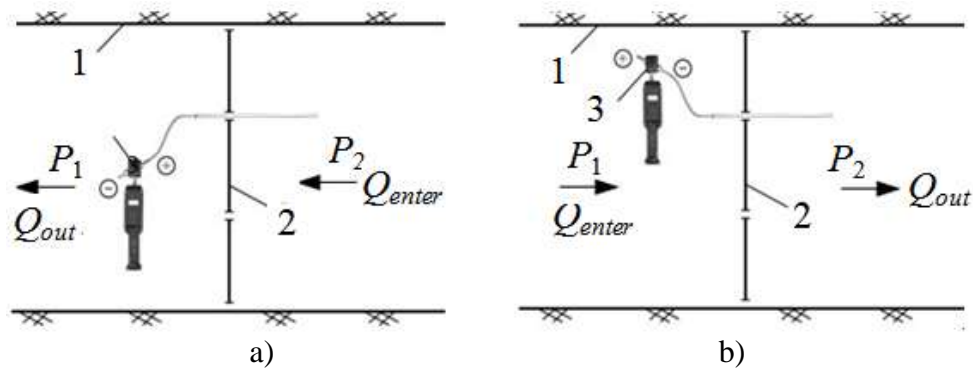

1 – mine working; 2 – ventilation structure; 3 – pressure difference converter

Figure 8 - Measurement of pressure drop on the ventilation structure, when the observer is near the ventilation structure from the low a) and high b) pressure

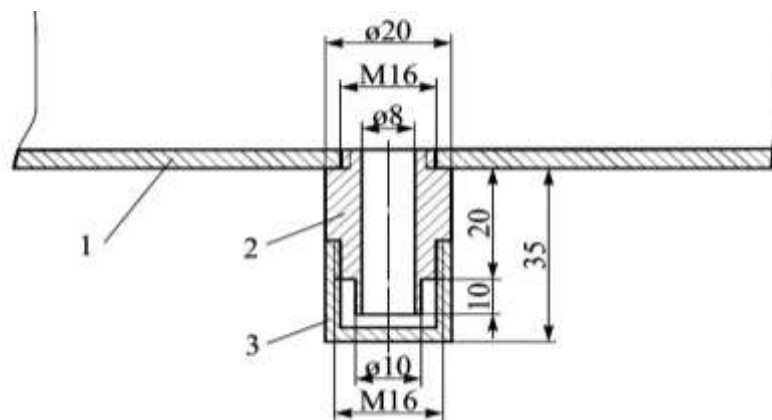

1 – pipeline; 2 – carbine; 3 – protective hubcap

Figure 9 - Device for connect

4. Such adjustment is carried out by Ventilation and Safety Technics District of Coal Mines, by steady (daily) control by the mining master of the district, which, moving established routes, conduct measurements of aerodynamic parameters of mine workings with portable control devices. Monitoring routes there are no constant, and adjusted by the head of the VTS district in accordance with current needs.

On the other hand, many Ukrainian mines are equipped with unified telecommunication automated dispatch control and direction systems of mining machines and technological complexes (UTAS) [4]. One of its functions is a control of the aerodynamic state of the workings of MVN, with the aim of which the system includes a complex of air velocity sensors TX1322 (or TX1322C (numerical)) and a complex of pressure sensors TX6101. Of course, that control is not the main function of UTAS, and the number of such sensors is confined, but their available basis allows you to get information about the aerodynamic state of the main control points and to transfer its to the mine dispatcher without additional interference. Thus, there is an opportunity to organize joint control of the aerodynamic parameters of the MVN elements, unconditionally whose advantages are the following.

First, such joint control will reduce the necessary measurements and reduction of the necessary points of routing control aerodynamics parameters, which, of course, will increase its reliability and efficiency for conditions reducing of labor costs.

Secondly, if the control route is compelled to cover the sensor area UTAS - it will be possible to evaluate the effectiveness of both components of control and correct location of UTAS sensors in mining. Keep in mind the fact that the sensitivity and accuracy of measurements of aerodynamic parameters by modern means of control (see item 3 of paragraph 3) is comparable or much greater than the sensitiveness of UTAS sensors.

Thus, the introduction of the proposed approach will allow for consideration advantages and eliminate the disadvantages of both components of the aerodynamic control system their parameters, reducing labor costs and contributing to increased security of miners. Apart, there will be an opportunity to optimize the amount of for necessary operation of the devices of stationary control aerodynamics- parameters (block 10 of Fig. 1), which, due to the limited production of it and the growth of the needs of mines is important.

5. Aerodynamic monitoring of ventilation during emergencies (block 11 Fig. 1) is a rather complicated problem due to the complexity of using existing devices in an emergency (it's hard to imagine the use of a pressure gauge with a rubber tube in a fire seat), and the implementation of operational control the aerodynamic state of the latter and especially isolated fire areas. The effectiveness of UTAS under these conditions is questionable, therefore monitoring with the use of modern control devices becomes essential.

6. The final, finished stage of evaluation and use of the results of the ADS is processing them using information and analytical technologies. These issues are devoted to several software products. This is, in particular, the most commonly used in Ukraine, developed by Naukovo-Doslidnyi Instytut Hirnychoriatuvalnoi Spravy ta Pozhezhnoi Bezpeky «Respirator» software complex "Ventilation of mines" [5], the RPPOD program [6], the program complex "IRS Ventilation-PLA" (development of Donetsk National Technical University [7], Russian complexes «Mine aerology (Ventilation)» [8] and "Air Network" [9]. However, the use of all of them successful causes in Ukraine is limited; moreover, they are not suitable for implementation of progressive approaches, described above. The most complete, which until then realizes the tasks of structural-parametric identification of the MVN, thus improving the use of the results of the ADS, is the development of IGTM NAS of Ukraine - Information and analytical technology of designing and spatial planning of coal mine ventilation systems "[10]. However, for more comprehensive coverage of the use of ADS results (as well as of course, and the results of the functioning of an integrated aerodynamic system control (see item 4 of paragraph 3) it requires some refinement. First of all It concerns the organization of a flexible graphical interface of the system, which is the most closer to our research.

Conclusions. The methods of structural and parametrical identification of mine ventilation network are developed, that enables to create its mathematical model, which, as a result of large degree of adequacy to the real network, can be effectively

used during ventilation calculations. It is suggested to replace the out-of-date devices of control aerodynamic parameters by more modern, developed in IGTM NAS of Ukraine. As an interval between conducting of the ADS on a mine is very considerable, is offered new approach to actualization of information, that consists in complexing of measurings by the stationary and portable devices of control. Methods structurally - parametrical authentication and the measurable devices of monitoring of aerodynamic parameters of a new technical level are offered first. The use of the offered methods and hardwares of working of the ADS results will allow to promote quality of got aerodynamic information.

REFERENCES

1. Bulat, A.F., Bunko, T.V., Yashchenko, I.A. et al. (2018), *Sovershenstvovaniye funktsionirovaniya ugolnykh shakht: ventilyatsiya, konditsionirovaniye, degazatsiya, ekologiya* [Perfection of functioning of coal mines: ventilation, conditioning, degassing, ecology], Zhurfond, Dnipro, UA.
2. Bulat, A.F., Krukovsky, A.P., Bunko, T.V. et al. (2017), "Estimation of danger of mines with the use of theory of risks", *Geo-Technical Mechanics*, no. 135, pp. 3-15.
3. Bulat, A.F., Zvyagilsky, Ye.L., Bokiy, B.V. et al. (2006), *Sovershenstvovaniye ventilyatsii i degazatsii ugolnykh shakht* [Perfection of ventilation and degassings of coal mines], Nord Computer, Dnepropetrovsk, UA.
4. Radchenko, V.V., Maleyev, N.V., Martynov, A.A. et al. (2005), "Prospects of increase of industrial strength security of coal mines at the use of the controller's checking system (UTAS)", *Gornyy informatsionno-analiticheskiy byulleten*, no. 5, pp. 31-43.
5. Kravchenko, M.V. and Kravchenko, N.M. (2003), "Experience of introduction of programmatic complex is «Ventilation of mines»", *Coal of Ukraine*, no. 2, pp. 26-28.
6. *Rukovodstvo po ekspluatatsii programmnoy sistemy REVOD. Versiya 4.2.* [Guidance on exploitation of the programmatic system REVOD. Version 4.2] (1999), Akademiya gorniyh nauk Ukrainyi, Donbasskiy nauchnyy tsentr, Donetsk, UA.
7. Trofimov, V.A. and Romanchenko, S.B. (2005), *Metodicheskiye ukazaniya po prakticheskim zanyatiyam «Modelirovaniye shakhtnykh ventilyatsionnykh setey»* [The methodical pointing on practical employments is «Design of mine vent networks»], DNTU, Donetsk, UA.
8. Paleev, D.Yu. and Lukashov, O.Yu. (2007), "Program of calculation of the vent regimes in mines and mines", *Mining industry*, nj. 6, p. 20.
9. Kazakov, B.P., Kruglov, Yu.V., Isayevich, A.G. and Levin, L.Yu. (2006), "Development of the programmatic-calculable complex «Aeronetwork» for the calculation of vent networks of mines and ore mines", *Gornyy informatsionno-analiticheskiy byulleten*, no. 10, pp. 21-32.
10. Poltavets, V.I., Bulat, A.F., Bunko, T.V. et al. (2003), *Ispolzovaniye kompyuternykh technologiy pri proyektirovanii ventilyatsii ugolnykh shakht.* [Use of computer technologies at designing of ventilation of coal mines], Nord-Komputer, Lugansk-Dnepropetrovsk, UA.

СПИСОК ЛІТЕРАТУРИ

1. Булат А.Ф., Бунько Т.В., Ященко І.А. і др. Совершенствование функционирования угольных шахт: вентиляция, кондиционирование, дегазация, экология. Дніпро: Журфонд, 2018. 444 с.
2. Булат А.Ф., Круковский А.П., Бунько Т.В. и др. Оценка опасности шахт с использованием теории рисков // Геотехническая механика: межвед. сб. науч. тр. / ИГТМ НАН Украины. 2017. Вып. 135. С. 3-15.
3. Булат А.Ф., Звягильский Е.Л., Бокий Б.В. и др. Совершенствование вентиляции и дегазации угольных шахт. Днепропетровск: Норд Компьютер, 2005. 216с.
4. Радченко В.В., Малеев Н.В., Мартынов А.А. и др. Перспективы повышения уровня промышленной безопасности угольных шахт при использовании системы диспетчерского контроля (УТАС) // Горный информационно-аналитический бюллетень. МГГУ: 2005. Тематический выпуск «Безопасность». С. 31-43.
5. Кравченко М.В., Кравченко Н.М. Опыт внедрения программного комплекса «Вентиляция шахт» // Уголь Украины. 2003. № 2. С. 26-28.
6. Руководство по эксплуатации программной системы РЕВОД. Версия 4.2. Донецк: Академия горных наук Украины, Донбасский научный центр, 1999. 71 с.
7. Трофимов В.А., Романченко С.Б. Методические указания по практическим занятиям «Моделирование шахтных вентиляционных сетей». Донецк: ДонНТУ, 2005. 28 с.
8. Палеев Д.Ю., Лукашов О.Ю. Программа расчета вентиляционных режимов в шахтах и рудниках // Горная промышленность. 2007. № 6. С. 20.
9. Казаков Б.П., Круглов Ю.В., Исаевич А.Г., Левин Л.Ю. Разработка программно-вычислительного комплекса «АэрСеть» для расчета вентиляционных сетей шахт и рудников // Горный информационно-аналитический бюллетень. Темат. прил. Аэрология. 2006. С. 21-32.
10. Полтавец В.И., Булат А.Ф., Бунько Т.В. и др. Использование компьютерных технологий при проектировании вентиляции угольных шахт. Луганск-Днепропетровск: Норд-компьютер, 2003. 343 с.

About the authors

Bunko Tetiana Viktorivna, Doctor of Technical Sciences (D.Sc), Senior Researcher, Senior Researcher in Department of Mineral Mining at Great Depths, Institute of Geotechnical Mechanics named by N. Poljakov of National Academy of Sciences of Ukraine (IGTM, NASU), Dnipro, Ukraine, bunko2017@ukr.net

Shyshov Maksym Valeriiovych, Master of Science, Head of the Technical Development Department of Coal Production directorate DFEK Energy, Kyiv, Ukraine

Myroshnychenko Vadym Volodymyrovych, Master of Science, Head of Ventilation and Degassing group Technical Development Department of Coal Production directorate DFEK Energy, Kyiv, Ukraine, miroshnichenkovvl@dtek.com

Kokoulin Ivan Yevhenovych, Candidate of Technical Sciences (Ph.D.), Senior Researcher, Senior Researcher in Department of Mineral Mining at Great Depths, Institute of Geotechnical Mechanics named by N. Poljakov of National Academy of Sciences of Ukraine (IGTM, NASU), Dnipro, Ukraine, bunko2017@ukr.net

Dudnyk Mikhaylo Mykolayovych, Master of Science, Junior Researcher in the Department of Rock Thermoaerodynamics and Automated Systems, Institute of Geotechnical Mechanics named by N. Poljakov of National Academy of Sciences of Ukraine (IGTM, NASU), Dnipro, Ukraine, dudnik1953@gmail.com

Про авторів

Бунько Тетяна Вікторівна, доктор технічних наук, старший науковий співробітник, старший науковий співробітник, Інститут геотехнічної механіки ім. М.С. Полякова Національної академії наук України (ІГТМ НАН України), Дніпро, Україна, bunko2017@ukr.net

Шишов Максим Валерійович, магістр, начальник Департаменту з технічного розвитку Дирекції по видобутку вугілля ДТЕК ЕНЕРГО, Київ, Україна

Мірошніченко Вадим Володимирович, магістр, начальник відділу вентиляції і дегазації Департаменту з технічного розвитку Дирекції по видобутку вугілля ДТЕК ЕНЕРГО, Київ, Україна, miroshnichenkovvl@dtek.com

Кокоулін Іван Євгенович, кандидат технічних наук, старший науковий співробітник у відділі проблем розробки родовищ на великих глибинах, Інститут геотехнічної механіки ім. М.С.Полякова Національної академії наук України (ІГТМ НАН України), Дніпро, Україна, bunko2017@ukr.net

Дудник Михайло Миколайович, магістр, молодший науковий співробітник у відділі гірничої термоаеродинаміки і автоматизованих систем, Інститут геотехнічної механіки ім. М.С. Полякова Національної академії наук України (ІГТМ НАН України), Дніпро, Україна, dudnik1953@gmail.com

Анотація. В умовах інтенсивного розвитку гірничих робіт вентиляційні мережі вугільних шахт стають більш протяжними і розгалуженими, внаслідок чого ускладнюється задача коректного прогнозування їх провітрювання. Розрахунки повітроділення у шахтній вентиляційній мережі (ШВМ) неможливі без використання сучасної обчислювальної техніки, а значить – створення математичної моделі ШВМ для проведення вентиляційних розрахунків. В основу її закладаються матеріали повітряно-депресійних зйомок (ПДЗ), що періодично проводяться на шахтах. Методологічні і технічні засоби отримання, контролю і актуалізації результатів ПДЗ потребують вдосконалення. З цією метою визначено питання, які не відповідають сучасним задачам ПДЗ щодо контролю аерологічного стану вугільних шахт. Розроблено методи структурної (оцінки адекватності розрахункової схеми, що будується, її реальному аналогу (у межах інформації, представленої розрахунковою схемою, і власного досвіду і сприйняття реального об'єкту споживачем)) і параметричної (оцінки і мінімізації відхилень значень для мереж, що аналізуються на адекватність, витрат повітря і депресій) ідентифікації вентиляційної мережі шахти. Пропонується замінити застарілі прилади контролю аеродинамічних параметрів більш сучасними, розробленими Інститутом геотехнічної механіки ім. Н.С. Полякова Національної академії наук України: портативним рудниковим анемометром АПР-2, дифференційним мікроманометром МДР-6, перетворювачем різниці тиску ПРД-1. Запропоновано новий підхід до актуалізації інформації, що полягає у комплексуванні вимірів стаціонарними і мобільними приладами контролю. Методи структурно - параметричної ідентифікації і прилади контролю аеродинамічних параметрів нового технічного рівня запропоновано вперше. Використання запропонованих методів і технічних засобів обробки результатів ПДЗ дозволять покращити якість отриманої аеродинамічної інформації.

Ключові слова: шахтна вентиляційна мережа, повітряно-депресійна зйомка, аеродинамічні параметри, актуалізація інформації, прилади контролю, адекватність.

Аннотация. В условиях интенсивного развития горных работ вентиляционные сети угольных шахт становятся более протяжными и разветвленными, в результате чего осложняется задача корректного прогнозирования их проветривания. Расчеты воздушораспределения в шахтной вентиляционной сети (ШВС) невозможны без использования современной вычислительной техники, а значит – создания математической модели ШВС для проведения вентиляционных расчетов. В основу ее закладываются материалы воздушно-депрессионных съемок (ВДС), периодически проводимых на шахтах. Методологические и технические средства

получения, контроля и актуализации результатов ВДС нуждаются в совершенствовании. С этой целью определены вопросы, которые не отвечают современным задачам ВДС в вопросах контроля аэрологического состояния угольных шахт. Разработаны методы структурной (оценки адекватности строящейся расчетной схемы ее реальному аналогу (в пределах информации, представленной расчетной схемой, и собственного опыта и восприятия реального объекта потребителем)) и параметрической (оценки и минимизации отклонений значений для сетей, анализируемых на адекватность, расходов воздуха и депрессий) идентификации вентиляционной сети шахты. Предлагается заменить устаревшие приборы контроля аэродинамических параметров более современными, разработанными Институтом геотехнической механики им. Н.С. Полякова Национальной академии наук Украины: портативным рудничным анемометром АПР-2, дифференциальным микроманометром МДР-6, преобразователем разницы давления ПРД-1. Предложен новый подход к актуализации информации, заключающийся в комплексировании измерений стационарными и мобильными приборами контроля. Методы структурно - параметрической идентификации и приборы контроля аэродинамических параметров нового технического уровня предложены впервые. Использование предложенных методов и технических средств обработки результатов ВДС позволят улучшить качество полученной аэродинамической информации.

Ключевые слова: шахтная вентиляционная сеть, воздушно-депресссионная съемка, аэродинамические параметры, актуализация информации, приборы контроля, адекватность.

Стаття надійшла до редакції 28.06.2019

Рекомендовано до друку д-ром техн. наук К.К. Софійським