

UDC 678.4.06:621.81

DOI: <https://doi.org/10.1051/e3sconf/201910900023>

## DYNAMICS OF VIBRATORY PARTITIONED FEEDERS FOR THE URANIUM ORE DRAWING AND FEEDING

<sup>1</sup>Dyrda V.I., <sup>2</sup>Kobets A.S., <sup>3</sup>Pukhalskyi V.N., <sup>4</sup>Kozub Yu.G., <sup>1</sup>Chernii O.A.

<sup>1</sup>Institute of Geotechnical Mechanics named by N. Poljakov of NAS of Ukraine, <sup>2</sup>Dnipro State Agrarian and Economic University, <sup>3</sup>Estern Mining and Processing Plant, <sup>4</sup>Luhansk Taras Shevchenko National University

## ДИНАМІКА ВІБРАЦІЙНИХ СЕКЦІОНОВАНИХ ЖИВИЛЬНИКІВ ДЛЯ ВИПУСКУ І ДОСТАВКИ УРАНОВИХ РУД

<sup>1</sup>Дурда В.І., <sup>2</sup>Кобець А.С., <sup>3</sup>Пухальський В.М., <sup>4</sup>Козуб Ю.Г., <sup>1</sup>Черній О.А.

<sup>1</sup>Інститут геотехнічної механіки ім. М.С. Полякова НАН України, <sup>2</sup>Дніпровський аграрно-економічний університет, <sup>3</sup>Державне підприємство «Східний гірничо-збагачувальний комбінат», <sup>4</sup>Луганський національний університет ім. Тараса Шевченка

## ДИНАМИКА ВИБРАЦИОННЫХ СЕКЦИОНИРОВАННЫХ ПИТАТЕЛЕЙ ДЛЯ ВЫПУСКА И ДОСТАВКИ УРАНОВЫХ РУД

<sup>1</sup>Дырда В.И., <sup>2</sup>Кобец А.С., <sup>3</sup>Пухальский В.М., <sup>4</sup>Козуб Ю.Г., <sup>1</sup>Черний А.А.

<sup>1</sup>Институт геотехнической механики им. Н.С. Полякова НАН Украины, <sup>2</sup>Днепроvский аграрно-экономический университет, <sup>3</sup>Государственное предприятие «Восточный горно-обогатительный комбинат», <sup>4</sup>Луганский национальный университет им. Тараса Шевченко

**Abstract.** Rate of the world economy growth is inextricably associated with development of energy industry. According to the International Energy Agency, world energy consumption will soon increase by one third; its deficit will be covered, among other things, by intensive development of nuclear power engineering. Today, nuclear-power industry is the only stably developing industry, which successfully competes with traditional sources of energy, such as oil, gas, coal, etc. Today, there are 15 nuclear power-generating units in Ukraine with a total capacity of more than 15 million kW presenting almost half of the country's total electricity. Ukraine is provided with sufficient reserves of raw materials and is among the top ten world producers of uranium. Ukraine began produce uranium ore in 1946 in the Zheltorechensky and Pervomaisky deposits; since 1951, all works were performed by the ore-mining complex No. 9 (now, it is the state enterprise "Eastern Mining and Processing Plant" in the city of Zhovti Vody). The "VostGOK" state company is the only enterprise, which extracts and processes uranium ores and produces natural uranium concentrate in full harmony with the world standards. Uranium ore is extracted by underground method; ore is drawn and fed from the panels by heavy mining vibratory feeders. In this paper, the authors consider dynamics of sectional vibratory feeders with rubber elastic couplings, and describe method for determining the feeder parameters and dependence between the feeder's intrinsic oscillation frequency and stiffness parameters of the drive section and platform length as well as ratio of oscillating masses in the feeder and platform. Use of vibratory feeders (including sectional ones) and schemes for the ore vibrating drawing, feeding and loading in underground conditions allowed to mechanize one of the most time-consuming and dangerous processes of uranium ore mining and to solve the following problems: to improve effectiveness of the lumpy rock mass drawing and loading by 2.5-3 times; to increase intensity of mining operations and reduce life of the excavation blocks and horizons; to reduce labor intensity and cut cost of the process of ore drawing and loading; to improve uniformity of the rock-mass outflowing from the discharge opening and to reduce by 3-5 times frequency of the large-lump material freezing (use of sectional feeders reduces number of freezes by 25-60 times); to increase size of commercial lump panels; practically to exclude traumas during the process of ore drawing and loading (usually, it presents 30-60% of all traumas caused by the underground operations); to mechanize process of ore drawing and loading, and to create conditions for implementation of low-waste cyclic-and-continuous mining technology.

**Keywords:** vibratory sectional feeder, feeder dynamics, uranium ore, frequency characteristics of vibratory feeders

### 1 Introduction

Rate of the world economy growth is inextricably associated with development of energy industry. According to the International Energy Agency, world energy consumption will soon increase by one third; its deficit will be covered, among other things, by intensive development of nuclear power engineering. Today, nuclear-power

industry is the only stably developing industry, which successfully competes with traditional sources of energy, such as oil, gas, coal, etc. Today, there are 15 nuclear power-generating units in Ukraine with a total capacity of more than 15 million kW presenting almost half of the country's total electricity. Ukraine is provided with sufficient reserves of raw materials and is among the top ten world producers of uranium. Ukraine began produce uranium ore in 1946 in the Zhovtorichenske and Pershotravenske deposits; since 1951, all works were performed by the ore-mining complex #9 (now, it is the state enterprise "Eastern Mining and Processing Plant" in the city of Zhovti Vody). The state company "Eastern Mining and Processing Plant" is the only enterprise, which extracts and processes uranium ores and produces natural uranium concentrate in full harmony with the world standards. Uranium ore is extracted by underground method; ore is drawn and fed from the panels by heavy mining vibratory feeders.

Today, underground method is used in all low-grade deposits and for mining at great depths in difficult mining, geological and technical conditions. At the same time, these complications decrease rate of development of underground ore mining and require significant improvement for mining equipment and technologies.

One of the most important technological processes in ore-deposit underground mining is drawing of broken rock from the working excavation zone and loading it into transport facilities. This process's share in total labor costs is up to 60 % and is associated with high level of injury of miners (up to 30-60 % of total underground mining operations).

The authors' scientific studies and their experience in designing and commissioning heavy vibratory-type machines show that the problem of highly effective and safety ore drawing and loading from the extraction blocks can be successfully solved by using vibratory feeders and complexes, which intensively effect the drawn material, reduce energy consumption and number of material freezes and ensure intensification and concentration of mining operations. Other technologies are also available, however, the vibratory drawing is still relevant today [1].

Vibratory drawing fully meets all modern challenges as it allows operating with rock-mass lumps with size of up to 1.2-1.4 m, ensuring technical productivity of 1500-2000 t/hr and producing not less than 1.2-1.5 million tons.

The overall decrease of mining operation rate and complications associated with deep horizons required intensification and concentration of mining operations in blocks and deposits, use of highly effective development systems with mass ore breakage by blasthole explosive charges, and transition to cyclic-and-continuous and continuous underground mining technologies. At the same time, the most critical constrain in this case was freezing of lumpy rocks.

In order to eliminate this negative effect and to intensify the process as a whole, an original scheme was studied and designed for the vibratory partitioned feeders, which allows to expand zone of vibration impact on the drawn material and, instead of discharge opening, to use discharge slot, which is significantly greater than maximum size of the drawn lumpy material. A new method of sectioning is used in design of small-sized vibratory feeders PVM-1,0/2,3, vibratory partitioned feeders PVS-1,4/7,0, and in vibratory partitioned mining complexes KVGS-1 (Fig. 1, Fig. 2).

Use of vibratory partitioned feeders and complexes instead of conventional ones allowed to reduce volume of tunneling operations, cut ore loss in the bottoms of the blocks and improve productivity and reliability of the process due to the much less number of freezes (by 25-60 times) with no additional expenditure of energy.

Uranium ore drawing with the help of vibratory feeders allows to expand zone of impact on the drawn rock mass, increase active cross-section of the stream and reduce risk of arch formation and, accordingly, number of freezes. Intensity of vibratory feeder action on the material in extraction zone is determined by the depth of penetration, which is about 0.4 m and can vary depending on operating conditions and method of breaking.

In order to make penetration deeper, it is necessary to increase significantly length of vibratory feeder, drive power, metal consumption and costs of assembling and disassembling. Besides, it should be mentioned that with increasing depth, static loads on the feeder and its elastic system also increase and can reach 50 tons or more [3].

Problems of uranium ore drawing and feeding are described in [2-4], where designs of vibratory feeders and some specific features of their operation are considered. Though, problem of partitioned feeder dynamics is still unsolved.

Objective of the work: to develop method for calculating dynamic characteristics of partitioned vibratory feeders and to determine dependence of intrinsic vibration frequencies on the stiffness of elastic couplings in the drive element and drive section, length of platform and ratio of vibrating rock mass in the section.

## 2 Method

### 2.1 Partitioned vibratory feeders

Structurally, they are simple: drive section is made on the basis of a well-known feeder and is equipped with a platform buried under a straight column of broken rock mass, which periodically receives oscillatory energy from the drive section under condition that it is released from the mass of the drawn material. Platform of partitioned feeder is turned on automatically and expands zone of vibration action on the column of broken rock mass, hence, eliminating processes of arch formation.

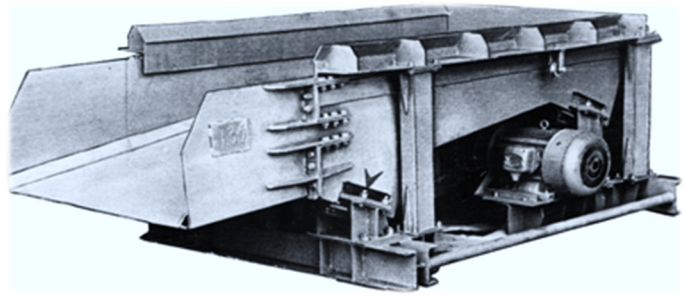
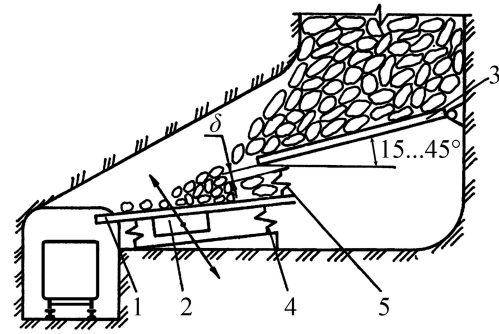

Figure 1 – Vibratory feeder of the VPR-4m type with the rubber elastic suspension (BRM type)



Figure 2 – Vibratory feeder of the VPR-4m type for the ore drawing and feeding from the panel to the wagons

In Figure 3, general dynamic scheme of partitioned feeder is shown. Front drive section 1 (it is based on, for example, VPR-4m) forms a transport stream and is equipped with own independent drive 2. Depending on use environment, drive section 1 can be deepened to a certain depth under the column of broken rock mass. The second section 3 (herein-after the platform) is located directly in the broken-down rock mass and does not have any drive. Platform 3 is turned on by restoring forces of elastic supports 4 in the drive section 1, oscillating work



1 – drive section; 2 – vibration exciter; 3 – platform; 4 – elastic supports of the drive section; 5 – elastic drive element  $C_1$ ;  $\delta$  – gap

Figure 3 – Dynamic scheme of vibratory partitioned feeder

member of which engages with the platform through the elastic drive element 5. At normal load, this drive section subsides on the elastic supports 4, disengages with the platform 3 and forms, between the platform and drive element  $C_1$ , a gap  $\delta$ , whose size is greater than or equal to the magnitude of oscillation amplitude of the drive section.

Rate of the drive elastic element compression and, consequently, rate of vibration transfer to the platform is inversely proportional to the amount of material on the work member in the drive section.

Certain differences in the kinematics of partitioned feeders, especially in kinematics and execution of their platform, predetermine a large variety of schemes for the ore drawing and loading in underground conditions, their dependence on the mining systems applied, thickness of ore bodies, needed completeness of excavation and geological and technical conditions of mining. Due to this, three types of partitioned feeders are proposed. Each of these types is characterized by method of platform supporting and type of the platform oscillations, and on the basis of these characteristics, strength and rigidity of the platform, its load-carrying capacity are determined. Depending on productivity and load-carrying capacity, partitioned feeders are conventionally divided into three types: light, medium and heavy.

Light-type feeders are designed for drawing and loading rock mass with size of up to 0.4 m when mining thin and vein deposits with ore shrinkage. Length of the platform is between 1 m to 2 m. The platform is a plate, whose front end is rest on oscillating work member of the driving section with the help of elastic element of the drive, and rear end of the platform is connected by hinge to the wall of tunnel or bunker. Angle of the platform inclination can be between  $15^\circ$  and  $45^\circ$  depending on specific location of the feeder. During operation, the feeder platform makes two types of oscillations: bending and angular relative to the hinge.

Medium-type feeders are designed for drawing ore directly from the box holes in the excavation blocks. These feeders should withstand significant pressure caused by column of broken-down rock mass and dynamic loads caused by blasting operations, which are needed for forming cutting slot, eliminating material freezing and crushing oversize rocks. Platform of such feeders is a plate with length of 2-4 m of the same or

variable stiffness, and it should be rested directly on the ore bench or longitudinal terrace at an angle of 20°-40°.

Medium-type feeders are used for mining thick and very thick ore deposits when oversize lumps presents more than 5 %. Principle of the platform operation assumes that broken rock mass moves on its inclined surface under the action of gravitational forces due to reduced effective coefficients of friction and adhesion of ore to the platform surface under the action of vibration transferred to the platform from the oscillating work member through the elastic element. Platform of medium-type partitioned feeder produces bending oscillations.

Heavy-type feeders are designed for operating in the conditions of blockage when ore can be crushed by the borehole explosive charges, for example, at lateral drawing of ore. In this case, mining operations require that the feeder should move together with front of ore-face operations and, hence, at multiple explosions of borehole charges. Length of the platform can be between 2 m and 4 m depending on step of the ore-face operation. In order to ensure more reliable drawing and loading operations, platform is rested on elastic couplings. Angle of the platform installation is 5°-15° to the horizon.

## 2.2 Dynamics of partitioned feeders

In terms of dynamics, the considered schemes of three types of partitioned feeders are multi-mass systems oscillating under the action of harmonic driving forces.

Calculations are based on the following assumptions: work member moves parallel to the plane; work member and platform are rigid bodies; dissipative forces are not taken into account; only vertical components of the oscillation amplitude are considered.

Let's consider light-type feeders.

Let's assume that  $X$  is direction of work member oscillation,  $\varphi$  is angular oscillations of the platform,  $w$  is deflection of the platform.

The expressions of the kinetic and potential energies in the selected generalized coordinates for the light-type feeders have the form:

$$E_k = \frac{m_1 \dot{X}^2}{2} + \frac{J \dot{\varphi}^2}{2} + \frac{\gamma_0 h_0}{2} \int_0^l \int_0^b \left( \frac{\partial w}{\partial t} \right)^2 dx dy;$$

$$E_p = \frac{C_1 X^2}{2} + \frac{C_n (X - w - \varphi l)^2}{2} +$$

$$+ \frac{D}{2} \int_0^l \int_0^b \left\{ \left( \frac{\partial^2 w}{\partial x^2} + \frac{\partial^2 w}{\partial y^2} \right)^2 - 2(1 - \mu) \left[ \frac{\partial^2 w}{\partial x^2} \frac{\partial^2 w}{\partial y^2} - \left( \frac{\partial^2 w}{\partial x \partial y} \right)^2 \right] \right\} dx dy, \quad (1)$$

In deriving the differential equations of motion of the considered dynamic system, we use the Ostrogradsky-Hamilton principle, which for conservative systems has the form:

$$S = \int_{t_1}^{t_2} L dt. \quad (2)$$

where  $L$  is the Lagrange function,  $L = E_k - E_p$ .

Then, composing on the basis of (1) the functional (2) and applying the Euler method, we obtain a system of differential equations describing the motion of a light-weight partitioned feeder

$$\begin{cases} m_1 \ddot{X} + (C_1 + C_n)X - C_n \phi l - C_n w(x, y, t) = P \sin \omega t; \\ J \ddot{\phi} + C_n \phi l^2 - C_n l X + C_n l w(x, y, t) = 0; \\ D \Delta w(x, y, t) + m_s \frac{\partial^2 w(x, y, t)}{\partial t^2} + C_n w(x, y, t) + C_n \phi l - C_n X = 0. \end{cases} \quad (3)$$

In equations (1), (3)  $J = m_s l^2 / 3$  – moment of inertia of the platform relative to the hinge;  $m_s$  is oscillating mass of the platform;  $l, b$  is length and width of the platform;  $\gamma_0, h_0$  is the density and thickness of the material of the platform;  $D = \frac{Ed^3}{12(1-\mu^2)}$  is cylindrical stiffness of the platform;  $m_1$  is mass of the work member in the drive section;  $C_1$  is stiffness of elastic supports in the drive section;  $C_n$  is stiffness of elastic supports of the platform;  $P = mg$  is load on the platform;  $E, \mu$  is modulus of elasticity and Poisson's ratio for the platform material;  $\Delta = \frac{\partial^2}{\partial x^2} + \frac{\partial^2}{\partial y^2}$  is the Laplace differential operator;  $\omega$  is frequency of oscillations.

Forced oscillations of a partitioned feeder are determined from the solution of the inhomogeneous system of equations (3).

Solving of the frequency equations for all 3 types of feeders makes it possible to determine dependence of intrinsic frequency  $f$  of the partitioned feeder on the stiffness of drive elastic element  $C_1$ , stiffness of elastic couplings of the drive section  $C_n$ , length of the platform  $l$ , and ratio of oscillating mass  $m_1/m_s$  in the sections (Fig. 4).

Rubber elements of elastic suspension in the platform and drive section were calculated by the method described in [5].

### 3 Conclusions

1. A new method was developed for calculating dynamic characteristics for the partitioned vibratory feeder and determining dependence of intrinsic oscillation frequency on parameters of the drive section, platform length and ratio of oscillating masses.

2. Vibratory machines and complexes created by the team of scientists and designers successfully operate in the mining enterprises of Ukrainian uranium industry, including PJSC “Northern Mining and Processing Plant” (Kryvyi Rih), PJSC “ArcelorMittal Kryvyi Rih”, Krivyy Rih Iron Ore Plant, production association “Uralzoloto”, Poltava Ore-Dressing and Processing Enterprise, mining enterprises of uranium industry in the Russian Federation, Kazakhstan, Kyrgyzstan and

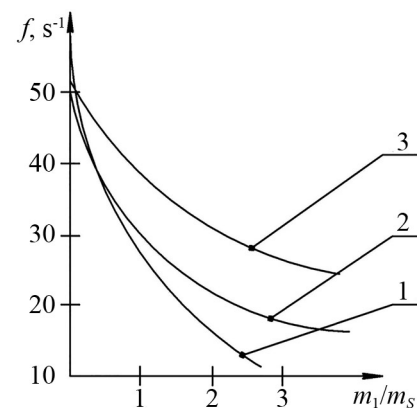

1 – light type; 2 – medium type; 3 – heavy type

Figure 4 – Dependence between the partitioned feeder's intrinsic frequency  $f$  and ratio of oscillating mass in sections  $m_1/m_s$

Uzbekistan. Volume of the rock-mass vibratory drawing in the state enterprise “Eastern Mining and Processing Plant” is about 100 %. Current annual manufacture is 20-25 vibratory feeders for different purposes.

#### REFERENCES

1. Puhalskiy, V.N., Sinchuk, V.V. and Basarab, N.N. (2017), “Production and processing of uranium ore in Ukraine”, *Geo-Technical Mechanics*, no. 133, pp. 27-33.
2. Poturaev, V.N., Dyrda, V.I. Poddubnyy, I.K. et al. (1989), *Vibrodostavochnyye komplekсы v tekhnologiyakh razrabotki rudnykh mestorozhdeniy* [Vibro-delivery complexes in ore mining technologies], Naukova dumka, Kyiv, USSR.
3. Kornev, G.N. (1968), *Povyshenie effektivnosti vibratsionnogo vypuska rudy iz blokov na osnove izucheniia mehanizma protsessa* [Improving the efficiency of vibrational ore extraction from blocks based on the study of the process mechanism], Nauka, Leningrad, USSR.
4. Poddubniy, I.K. (1982), “Industrial studies of operating modes and structural elements of vibrating mining feeders”, *Metallurgicheskaya i gornorudnaya promyshlennost* [Metallurgical and mining industry], no. 2, pp. 43-44.
5. Bulat, A.F., Dyrda, V.I., Lysytsya, M.I. and Grebenyuk, S.M. (2018), “Numerical Simulation of the Stress-Strain State of Thin-Layer Rubber-Metal Vibration Absorber Elements Under Nonlinear Deformation”, *Strength of Materials*, no. 3 (50), pp. 387-395.  
DOI: <https://doi.org/10.1007/s11223-018-9982-9>

#### СПИСОК ЛІТЕРАТУРИ

1. Пухальський В.Н., Синчук В.В., Басараб Н.Н. Добыча и переработка урановой руды в Украине. *Геотехническая механика*. 2017. Вып. 133. С. 27-33.
2. Вибродоставочные комплексы в технологиях разработки рудных месторождений / В.Н. Потураев, В.И. Дырда и др. К.: Наук. думка, 1989. 167 с.
3. Корнев Г.Н. Повышение эффективности вибрационного выпуска руды из блоков на основе изучения механизма процесса. Л.: Наука, 1968. 95 с.
4. Поддубный И.К. Промышленные исследования режимов работы и конструктивных элементов горных вибропитателей. *Металлургическая и горнорудная промышленность*. 1982. №2. С. 43-44.
5. Numerical Simulation of the Stress-Strain State of Thin-Layer Rubber-Metal Vibration Absorber Elements Under Nonlinear Deformation / Bulat A.F., Dyrda V.I., Lysytsya M.I., Grebenyuk S.M. *Strength of Materials*. 2018. No. 3 (50). P. 387-395.  
DOI: <https://doi.org/10.1007/s11223-018-9982-9>

#### About the authors

**Dyrda Vitalii Illarionovych**, Doctor of Technical Sciences (D. Sc.), Professor, Head of Department of Elastomeric Component Mechanics in Mining Machines, Institute of Geotechnical Mechanics named by N. Poljakov of National Academy of Science of Ukraine, Dnipro, Ukraine, [vita.igtm@gmail.com](mailto:vita.igtm@gmail.com)

**Kobets Anatolii Stepanovych**, Doctor of Public Administration, Professor, Rector, Dnipro State University of Agriculture and Economics, Dnipro, Ukraine, [info@dsau.ua](mailto:info@dsau.ua)

**Pukhalskiy Viktor Mykolaiovych**, Candidate of Technical Sciences (Ph. D.), Chief Engineer in Eastern Mining and Processing Plant, Jovti Vody, Ukraine, [referent@vostgok.dp.ua](mailto:referent@vostgok.dp.ua)

**Kozub Yuriy Hordiiovych**, Candidate of Technical Science (Ph. D.), Head of the Department of Physical-Technical Systems and Informatics, Lugansk Taras Shevchenko National University, Starobilsk, Ukraine, [kosub.yg@gmail.com](mailto:kosub.yg@gmail.com)

**Chernii Oleksandr Anatoliiovych**, Master of Science, Senior Lecturer of Department “Reliability and repair of machines”, Dnipro State Agrarian and Economic University, Dnipro, Ukraine, [sanek20.1984@gmail.com](mailto:sanek20.1984@gmail.com)

#### Про авторів

**Дырда Віталій Ілларіонович**, доктор технічних наук, професор, завідувач відділу механіки еластомерних конструкцій гірничих машин, Інститут геотехнічної механіки ім. М.С. Полякова Національної академії наук України (ІГТМ НАНУ), м. Дніпро, Україна, [vita.igtm@gmail.com](mailto:vita.igtm@gmail.com)

**Кобець Анатолій Степанович**, доктор наук з держуправління, професор, ректор, Дніпровський державний аграрно-економічний університет (ДДАЕУ), м. Дніпро, Україна, [info@dsau.ua](mailto:info@dsau.ua)

**Пухальський Віктор Миколайович**, кандидат технічних наук, головний інженер СхідГЗК, м. Жовті Води, Україна, [referent@vostgok.dp.ua](mailto:referent@vostgok.dp.ua)

**Козуб Юрій Гордійович**, кандидат технічних наук, доцент, завідувач кафедри фізико-технічних систем та інформатики, Луганський національний університет ім. Тараса Шевченка (ЛНУ ім. Тараса Шевченка), м. Старобільськ, Україна, [kosub.yg@gmail.com](mailto:kosub.yg@gmail.com)

**Черній Олександр Анатолійович**, магістр, старший викладач кафедри «Надійність та ремонт машин», Дніпровський державний аграрно-економічний університет (ДДАЕУ), м. Дніпро, Україна, [sanek20.1984@gmail.com](mailto:sanek20.1984@gmail.com)

**Анотація.** Темпи зростання світової економіки нерозривно пов'язані з розвитком енергетичної галузі. За оцінкою Міжнародного енергетичного агентства світове енергоспоживання найближчим часом зросте на третину; покриття дефіциту буде здійснюватися в тому числі і за рахунок розвитку атомної енергетики. На сьогоднішній день атомна промисловість є єдиною галуззю, що стабільно розвивається та успішно конкурує з традиційними

джерелами енергії, такими, як нафта, газ, вугілля та ін. На сьогоднішній день в Україні в експлуатації знаходиться 15 атомних енергоблоків із загальною потужністю понад 15 млн. кВт, що становить майже половину всього обсягу електроенергії країни. Україна забезпечена достатніми запасами сировини і входить в десятку світових виробників урану. Видобуток уранової руди в Україні розпочався в 1946 році на Жовторіченському і Первомайському родовищі; з 1951 року всі роботи виконував комбінат № 9 (в даний час Державне підприємство «Східний гірничо-збагачувальний комбінат», м. Жовті Води). ДП «СхідГЗК» є єдиним підприємством, яке здійснює видобуток уранових руд, їх переробку і виробництво концентрату природного урану, який відповідає вимогам світових стандартів. Видобуток уранових руд здійснюється підземним способом; випуск і доставка руди з блоків – за допомогою важких гірничих вібраційних живильників. В роботі розглядається динаміка секціонованих віброживильників з гумовими пружними зв'язками; викладається метод визначення параметрів живильника і визначення залежності його власної частоти коливань від характеристик жорсткості параметрів приводної секції, довжини платформи і співвідношення мас живильника і платформи, що коливаються. Застосування вібраційних живильників (в тому числі і секційних) і схем вібраційного випуску, доставки і навантаження руди в підземних умовах дозволило механізувати один з найбільш трудомістких і небезпечних процесів видобутку уранової руди і вирішити при цьому наступні завдання: збільшити продуктивність випуску і навантаження крупнокускової гірської маси в 2,5-3 рази; збільшити інтенсивність відпрацювання і зменшити термін експлуатації очисних блоків і горизонтів; зменшити трудомісткість і знизити собівартість процесу випуску та навантаження руди; підвищити рівномірність витікання гірської маси з випускних отворів і знизити в 3-5 разів частоту зависань крупнокускового матеріалу; застосуванням секціонованих живильників кількість зависань знижується в 25-60 разів; збільшити розмір кондиційного виїмкового шматка; практично виключити випадки травматизму на процес випуску і навантаження, що займають 30-60 % від усіх випадків на підземних роботах; механізувати процес випуску і навантаження і створити умови для здійснення маловідходної циклічно-поточної технології видобутку.

**Ключові слова:** вібраційний секціонований живильник, динаміка живильників, уранова руда, частотні характеристики віброживильників

**Анотація.** Темпы роста мировой экономики неразрывно связаны с развитием энергетической отрасли. По оценке Международного энергетического агентства мировое энергопотребление в ближайшее время вырастет на треть; покрытие дефицита будет осуществляться в том числе и за счёт развития атомной энергетики. На сегодняшний день атомная промышленность является единственной стабильно развивающейся отраслью, успешно конкурирующей с традиционными источниками энергии, такими, как нефть, газ, уголь и др. На сегодняшний день в Украине в эксплуатации находится 15 атомных энергоблоков с общей мощностью более 15 млн. кВт, что составляет почти половину всего объёма электроэнергии страны. Украина обеспечена достаточными запасами сырья и входит в десятку мировых производителей урана. Добыча урановой руды в Украине началась в 1946 году на Желтореченском и Первомайском месторождении; с 1951 года все работы выполнял комбинат № 9 (в настоящее время Государственное предприятие «Восточный горно-обогатительный комбинат», г. Жёлтые Воды). ГП «ВостГЗК» является единственным предприятием, которое осуществляет добычу урановых руд, их переработку и производство концентрата природного урана, который соответствует требованиям мировых стандартов. Добыча урановых руд осуществляется подземным способом; выпуск и доставка руды с блоков – с помощью тяжёлых горных вибрационных питателей. В работе рассматривается динамика секционированных вибропитателей с резиновыми упругими связями; излагается метод определения параметров питателя и определение зависимости его собственной частоты колебаний от жесткостных параметров приводной секции, длины платформы и соотношения колеблющихся масс питателя и платформы. Применение вибрационных питателей (в том числе и секционных) и схем вибрационного выпуска, доставки и погрузки руды в подземных условиях позволило механизировать один из наиболее трудоёмких и опасных процессов добычи урановой руды и решить при этом следующие задачи: увеличить производительность выпуска и погрузки крупнокусковой горной массы в 2,5-3 раза; увеличить интенсивность отработки и уменьшить срок эксплуатации очистных блоков и горизонтов; уменьшить трудоёмкость и снизить себестоимость процесса выпуска и погрузки руды; повысить равномерность истечения горной массы из выпускных отверстий и снизить в 3-5 раз частоту зависаний крупнокускового материала; применением секционированных питателей количество зависаний снижается в 25-60 раз; увеличить размер кондиционного выемочного куска; практически исключить случаи травматизма на процесс выпуска и погрузки, занимающие 30-60 % от всех случаев на подземных работах; механизировать процесс выпуска и погрузки и создать условия для осуществления малоотходной циклично-поточной технологии добычи.

**Ключевые слова:** вибрационный секционированный питатель, динамика питателей, урановая руда, частотные характеристики вибропитателей

*Статья поступила в редакцию 17.02.2020*

*Рекомендовано к печати д-ром техн. наук. В.П. Надутым*