

THE METHOD FOR DRIVING PREPARATORY ROADWAY IN GAS-SATURATED ROCKS PRONE TO GAS-DYNAMIC PHENOMENA

¹Minieiev S.P., ¹Vasilyev L.M., ¹Trokhymets M.Ya., ¹Maltseva V.Ye.,
²Vialushkin Ye.O., ³Polushyna M.V.

¹M.S. Poliakov Institute of Geotechnical Mechanics of the National Academy of Sciences of Ukraine, ²Institute of Industrial and Business Technologies of the Ukrainian State University of Science and Technology, ³Dnipro University of Technology

Abstract. The paper describes the method for safe driving preparatory roadway in gas-saturated rocks prone to gas-dynamic phenomena by applying a set of additional measures to ensure outburst safety in the underground space.

As a result of the analysis of different methods for driving preparatory roadway in gas-saturated rocks prone to gas-dynamic phenomena, the authors of this article designed a new safest method for driving preparatory roadway in gas-saturated rocks prone to gas-dynamic phenomena at the level of the Ukrainian patent No. 151296 for utility model. In order to ensure outburst safety while driving preparatory roadway, additional technological measures must be taken to prevent outburst of coal and gas before heading machine starts to work.

The method includes preliminary drilling of degassing, unloading and injection boreholes in the mine face plane. Before the driving, preliminary reliable information about the categorical need for degassing of the near face zone of rock massif must be obtained. After the degassing, a decision on the safety of further driving with mechanical destruction of the mine face by a heading machine should be made if the following simultaneously obtained indicators are: the gas pressure in the sealed axial injection borehole after degassing is not more than 0.5 MPa; the gas concentration around mine face is not more than 1%; the diameter deformation of discharge holes is not less than 20% from their initial value.

The developed method is carried out by a device consisting of a reinforced rubber flexible hose with seals installed at its ends, inlet and outlet faucets for supplying water to the sealer and draining it away. A metal probe (tube) with a length exceeding the length of the daily works heading is placed in the seals of the sealer with a sliding fit. The metal probe is connected to a pressure gauge. The device is placed in the cavity of a borehole drilled in the centre of the mine face surface along the direction of the preparatory roadway drivage to the depth equal to the length of the daily works heading. After sealing the borehole, the gas pressure in the cavity behind the sealer is measured along its entire length.

The implementation of the developed method for safe driving preparatory roadway in gas-saturated rocks prone to gas-dynamic phenomena by a heading machine can give a good technical result to the mining industry - a significant safety improvement of preparatory roadway drivage, as well as provision of stable speed and continuous mine working as a result of the applying technological measures for preventing sudden gas outbursts.

Keywords: preparatory roadway, gas-dynamic phenomena, degassing, heading machine.

1. Introduction

Nowadays, the preparatory roadway driving is carried out in highly gas-saturated coal seams, as a rule, prone to gas-dynamic phenomena. Their exploitation causes the release of methane and other gases from coal seams and host rocks, which contributes to outbursts of coal, host rocks and gas. In recent years in Ukraine, methane explosions in the underground mine workings mostly occurred in excavation areas with the estimated methane release from 1.67 m³/min to 32.3 m³/min [1]. The facts of the occurred explosions and their frequency increase in the areas with methane emission up to 3 m³/min indicate the necessity of developing a method using a set of additional measures to ensure emission safety in underground space during the preparatory roadway driving in gas-saturated rocks prone to gas-dynamic phenomena.

The theory of sudden outbursts of coal and gas into the worked-out space (roadway) asserts that in order to prevent gas-dynamic phenomena it is enough to fulfil one of the following conditions:

- to reduce the stressed state of the gas-bearing coal massif;
- to reduce the gas pressure in the seam (change the gas content of the massif);

- to change the properties of the seam [2].

The known methods to prevent gas-dynamic phenomena [3–6] have the following disadvantages. There is no possibility of obtaining preliminary reliable information about the categorical necessity of degassing the near face zone of rock massif, and after degassing - information about the safety of further development heading with mechanical destruction of the mine face by a heading machine.

The analysis of the developed methods to prevent gas-dynamic phenomena revealed a problem - none of them guarantees the complete exclusion of the occurrence of sudden outbursts of coal, rock and gas, as well as the lack of technological means for timely obtaining preliminary reliable information about the safety of further development heading by a heading machine. Therefore, the development of new methods and technological means in order to avoid the outburst hazard of gas-bearing coal seams during development heading by heading machine is an actual problem nowadays.

The purpose of the research is to design a safe method for preparatory roadway driving in gas-saturated rocks prone to gas-dynamic phenomena by using a set of additional technological measures to ensure outburst safety in the underground space.

2. Method

On the basis of the analysis of information given in [7], the authors developed a practically safe method for preparatory roadway driving in gas-saturated rocks prone to gas-dynamic phenomena.

The implementation of the proposed method for preparatory roadway driving in gas-saturated rocks prone to gas-dynamic phenomena by heading machine according to [7] includes the preliminary drilling of degassing, unloading and injection boreholes in the plane of the mine face and subsequent mechanical destruction of the mine face by working organ of the heading machine. Before beginning the preparatory roadway drivage, the gas pressure must be measured in the borehole in the centre of the mine face plane. This borehole should have a depth exceeding the length of daily cycle of works heading. Measurements of gas pressure in the cavity of the sealed axial borehole should be carried out at intervals not more than every 0.5 m. If there is a definite need for degassing (hydro-loosening) of the near face zone of rock massif (if gas pressure is 0.5 MPa and more), this axial borehole is used as an injection borehole. After the degassing and unloading of the near face zone of rock massif, a control measurement of the gas pressure in the same injection hole is also taken for at least one hour for obtaining reliable information about the safety of further mechanical destruction of the mine face by the working organ of the heading machine. A decision on the safety of further development heading with mechanical destruction of a mine face by a heading machine must be made if the simultaneously obtained indicators are as follows: the gas pressure in the sealed axial injection borehole after degassing is not more than 0.5 MPa; the gas concentration around mine face is not more than 1%; the deformation of discharge holes diameter is not less than 20% from their initial value.

3. Results and discussion

The essence of the new method is explained in the drawing (Figure 1), which shows the equipment for measuring gas pressure and the scheme for its placing in the hole at a distance that is not less than the length of $L_g + X$, where L_g is the sealing length (at least 0.5 m), and X is the depth of the daily cycle of works heading. Figure 2 demonstrates a cross-section of the development working with the equipment placement scheme for measuring gas pressure in a pre-drilled borehole in the centre of the face plane. The diagrams (Figs. 1 and 2) consist of a borehole sealer 1, at least 0.5 m long, with a fitting 2, to which a supply pipe 3 with a faucet 4 and an outlet pipe 5 with faucet 6 are attached. A tube 7 is placed in borehole sealer 1, the free end of which enters the borehole cavity. The second end of the tube 7, which goes out from borehole sealer 1 into the worked-out space (roadway), is equipped with a pressure gauge 8 and a device 9 for moving tube 7 in borehole sealer 1. Inlet pipe 3 is connected to hydraulic pumping unit 10 with a flexible hose 11. Hydraulic pumping unit 10 is placed on a heading machine 12 and is connected to a water fire fighting unit 13 through a flexible hose 14 with a faucet 15.

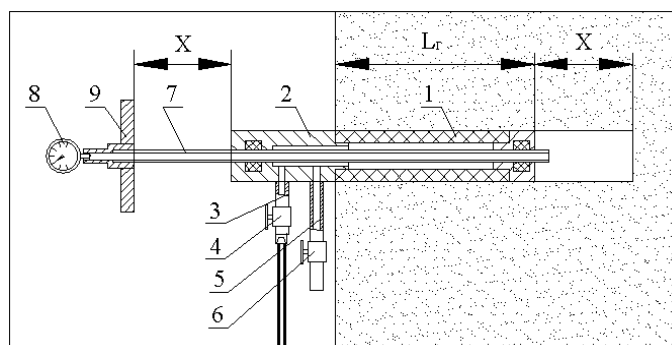

L_g - length of sealing (not less than 0.5 m); X - depth of the daily cycle of works heading

Figure 1 – Equipment for measuring gas pressure and its placement diagram in the borehole

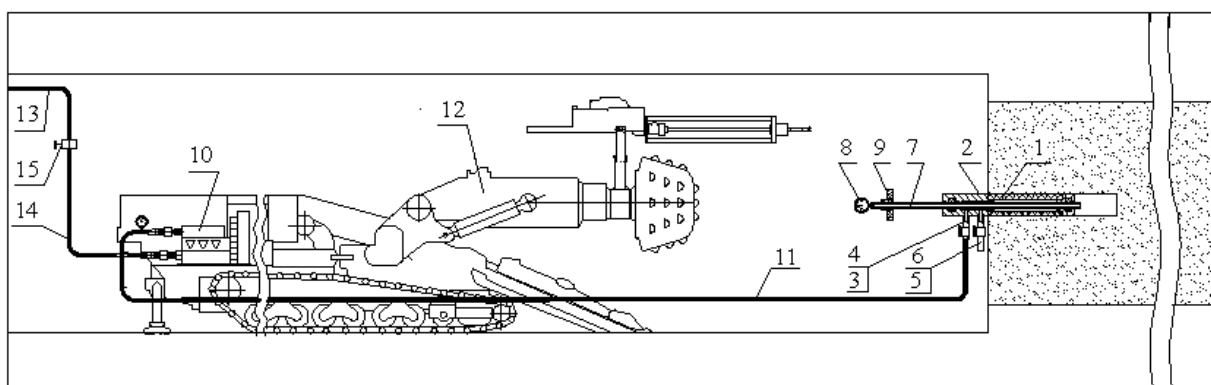

Figure 2 – Equipment placement scheme for measuring gas pressure in a pre-drilled by a heading machine borehole in the centre of the face plane of development working

The developed method for safe preparatory roadway driving in gas-bearing rocks prone to gas-dynamic phenomena by heading machine is carried out as follows. Sealer 1 (Figures 1, 2), equipped with tube 7, supply pipe 3 with faucet 4, outlet pipe 5 with faucet 6 and pressure gauge 8, is placed in the borehole cavity to a depth of at least 0.5 m. When faucet 6 on outlet pipe 5 is closed, faucet 15 on flexible hose 14 is opened, hydraulic pump unit 10 is turned on and water is fed into sealer 1 through opened faucet 4 under pressure of 10 to 15 MPa. At constant water pressure, the sealer seals the borehole mouth. The sealed cavity of the borehole is connected through tube 7 to manometer 8, which measures the value of the gas pressure in the borehole cavity. Then hydraulic unit 10 is turned off, faucet 4 is closed, faucet 6 is opened and tube 7 is manually moved in the cavity of the sealer to a distance of not more than 0.5 m. Gas pressure measurements are taken at intervals of every 0.5 m along the borehole. According to [7], when the gas pressure in the borehole cavity is 0.5 MPa and more, the operation on degassing and unloading of the working face area of massif is performed [8].

After degassing according to [8], a control measurement of the gas pressure is carried out according to [7] for at least one hour for obtaining reliable information about the safety of further mechanical destruction of the working face by the working organ of the heading machine. When simultaneously obtained indicators are as follows: the gas pressure in the sealed axial injection borehole after degassing is not more than 0.5 MPa, the gas concentration in the cavity of the injection borehole and in the working face area is not more than 1%, as well as the deformation of the discharge boreholes is not less than 20% of their of the initial diameter, a decision on the safety of further development heading with mechanical destruction of the mine face by the heading machine is made according to [9].

4. Conclusions

The method of safe preparatory roadway driving in gas-saturated rocks prone to gas-dynamic phenomena was worked out. The implementation of the developed method can give a good technical result to the mining industry - a significant safety improvement of preparatory roadway drivage in gas-saturated rocks prone to gas-dynamic phenomena by the heading machine, as well as provision of a stable speed and continuous operation of gallery as a result of the applying technological measures to prevent sudden gas outburst. These measures consist in timely obtaining preliminary reliable information about the categorical necessity of degassing the near mine face zone of the rock massif, and after the degassing - information about the safety of further development heading with mechanical destruction of the mine face by the working organ of the heading machine.

REFERENCES

1. Bulat, A.F., Mineev, S.P., Belikov, S.N. and Belikov, I.B. (2021), *Pozhary v gornykh vyrabotkakh. Izolyatsiya avariynykh uchastkov* [Fires in mine workings. Isolation of emergency areas], V delye, Kharkov, Ukraine.
2. (2015), *Pravyla bezpeky u vugilnykh shakhtakh* [Safety rules in coal mines], Fort, Kharkov, Ukraine.
3. Minvugleprom of Ukraine (2005), SOU 10.1.00174088.011-2005. *Pravyla vedennya hirnychykh robit na plastakh, skhylnykh do hazodynamichnykh yavlyshch* [SOU 10.1.00174088.011-2005. Rules for conducting mining operations on layers prone to gas-dynamic phenomena], Ukraine Ministry of Coal Industry, Kiev, Ukraine.

4. Koptikov, V.P., Bokiy, B.V., Mineev, S.P., Yuzhanin, I.A. and Nikiforov, A.V. (2016), *Sovershenstvovaniye sposobov I sredstv bezopasnoy razrabotki ugolnykh plastov, sklonnykh k gazodinamicheskim yavleniyam* [Improvement of Methods and Means of Safe Development of Coal Plates Prone to Gasodynamic Phenomena], Promin, Donetsk, Ukraine.

5. Mineev, S.P. (2016), *Prognoz I predotvrashcheniye vybrosov uglja I gaza na shakhtakh Ukrainy* [Forecast and prevention of coal and gas emissions from Ukraines mines], Skhidny vidavnicchiy Dim, Donetsk, Ukraine.

6. Mineev, S.P., Iliushchenko, A.V., Vostretsov, N.A., Medvedev, V.V. and Volosetskiy, K.I. (2018), *Vskrytiye vybrosoopasnykh ugolnykh plastov prokhodcheskymi kombaynami* [Autopsy of hazardous coal seams by passing combines], Dnepr-Kiyev: FLP Khalikov, Ukraine.

7. Trokhymets, M.Ya., Maltseva, V.Ye., Vialushkin, Ye.O., Vasilev, L.M. and Mineev, S.P., M.S. Poljakov Institute of Geotechnical Mechanics under NAS of Ukraine (2022), *Sposib provedennya pidhotovchykh vyrobok po hazonasychenym hirs'kym porodam, shyl'nym do hazodynamichnykh yavyshch, prokhidnytskym kombaynom* [The method of carrying out preparatory works on gas-saturated rocks, prone to gas-dynamic phenomena, with a walk-behind combine], State Register of Patents of Ukraine, Kiev, UA, Pat. № 151296.

8. Usov, O.O., Trokhymets, M.Ya., Vasilev, D.L., Poliakov, Yu.Ye., Potapenko, O.O. and Anhelovskyi, O.A., M.S. Poljakov Institute of Geotechnical Mechanics under NAS of Ukraine (2012), *Sposib dehazatsiyi hazonasychenoho vykydonebezpechnoho vuhil'noho plasta* [Method of degassing a gas-saturated, release-hazardous coal seam], State Register of Patents of Ukraine, Kiev, UA, Pat. № 68478.

9. Trokhimets, M.Ya., Maltseva, V.Ye., Vialushkin, O.Ye. and other, M.S. Poljakov Institute of Geotechnical Mechanics under NAS of Ukraine (2018), *Sposib provedenia pidhotovchoi vyrobki po gazonosnomu vykydonebezpechnomu vuyil'nomu plastu prokhidnytskym kombainom* [Method of carrying out preparatory production on a gas-saturated, emission-hazardous coal seam with a walk-behind combine], State Register of Patents of Ukraine, Kiev, UA, Pat. № 122179.

About the authors

Minieiev Serhii Pavlovych, Doctor of Technical Sciences (D.Sc.), Professor, Head of Department of Pressure Dynamics Control in Rocks, M.S. Poliakov Institute of Geotechnical Mechanics of the National Academy of Sciences of Ukraine (IGTM of the NAS of Ukraine), Dnipro, Ukraine, sergmineev@gmail.com.

Vasyliev Leonid Mikhaylovych, Doctor of Technical Sciences (D.Sc.), Professor, Senior Researcher in Department of Pressure Dynamics Control in Rocks, M.S. Poliakov Institute of Geotechnical Mechanics of the National Academy of Sciences of Ukraine (IGTM of the NAS of Ukraine), Dnipro, Ukraine.

Trokhymets Mykola Yakovych, Candidate of Technical Sciences (Ph.D.), Senior Researcher in Department of Pressure Dynamics Control in Rocks, M.S. Poliakov Institute of Geotechnical Mechanics of the National Academy of Sciences of Ukraine (IGTM of the NAS of Ukraine), Dnipro, Ukraine.

Maltseva Vira Yevhenivna, Senior Engineer in Department of Pressure Dynamics Control in Rocks, M.S. Poliakov Institute of Geotechnical Mechanics of the NAS of Ukraine (IGTM of the NAS of Ukraine), Dnipro, Ukraine.

Vialushkin Yehor Olehovych, Engineer, Institute of Industrial and Business Technologies of the Ukrainian State University of Science and Technology, Dnipro, Ukraine.

Polushyna Maryna Vitaliivna, Candidate of Technical Science (Ph.D.), Associate Professor, Associate Professor in Department of Engineering and Design in Machinery Industry, Dnipro University of Technology (NTU "DP"), Dnipro, Ukraine, polushyna.m.v@nmu.one.

СПОСІБ ПРОВЕДЕННЯ ПІДГОТОВЧОЇ ВИРОБКИ ПО ГАЗОНАСИЧЕНИХ ГІРСЬКИХ ПОРОДАХ, СХИЛЬНИХ ДО ГАЗОДИНАМІЧНИХ ЯВИЩ

Мінєєв С.П., Васильєв Л.М., Трохимець М.Я., Мальцева В.Є., Вялушкін Є.О., Полушина М. В.

Анотація. В статті описано спосіб безпечного проведення підготовчої виробки по газонасичених гірських породах, схильних до газодинамічних явищ (ГДЯ), з застосуванням комплексу додаткових технологічних заходів щодо забезпечення викидбезпеки в підземному просторі.

На основі аналізу існуючих способів проведення підготовчої виробки по газонасичених гірських породах, схильних до ГДЯ, на рівні патенту України на корисну модель № 151296 розроблено новий найбільш безпечний спосіб проведення підготовчої виробки по газонасичених гірських породах, схильних до ГДЯ. При здійсненні цього способу, для забезпечення викидбезпеки, застосовують комплекс додаткових технологічних заходів щодо запобігання раптовим викидам вугілля та газу перед початком проведення робіт прохідницьким комбайном.

Спосіб включає попереднє буріння дегазаційних, розвантажувальних та нагнітальних шпурів в площині вибою виробки. Перед початком виконання прохідницьких робіт по проведенню виробки попередньо отримують достовірну інформацію про категоричну необхідність дегазації привибійної зони гірського масиву. А після дегазації по одночасному отриманню показників, таких як: тиск газу в загерметизованому осьовому нагнітальному шпурі після дегазації не більше 0,5 МПа, концентрація газу біля вибою виробки не більше 1%, а також не менше 20% дефор-

мація розвантажувальних шпурів від їх початкового діаметру, приймають рішення про безпечність подальшого проведення прохідницьких робіт шляхом механічного руйнування вибою виробки прохідницьким комбайном.

Розроблений спосіб здійснюють за допомогою пристрою, який складається з гумового армованого гнучкого рукава, на кінці якого закріплені ущільники, а між ними підвідний та відвідний крани для подачі води у герметизатор та спуску з нього. В ущільниках герметизатора по ковзній посадці розміщений металевий щуп (трубка) довжиною, що перебільшує довжину добового проведення виробки. Металевий щуп з'єднаний з манометром. Пристрій розміщують у порожнині шпура, пробуреного в центрі поверхні вибою по ходу виробки на глибину довжиною добового її проведення. Після герметизації шпура здійснюють вимір тиску газу у порожнині за герметизатором по всій довжині.

Впровадження розробленого способу в гірничу галузь може дати технічний результат – значне підвищення рівня безпеки при здійсненні способу проведення підготовчої виробки по газонасичених гірських породах, схильних до ГДЯ, прохідницьким комбайном, а також забезпечення стабільної швидкості проведення виробки і безперервної роботи внаслідок реалізації технологічних засобів щодо запобігання раптовим викидам вугілля та газу.

Ключові слова: підготовча виробка, газодинамічні явища, дегазація, прохідницький комбайн.