

## DISC-TYPE PRESS FILTER AND ITS INDUSTRIAL TESTING

<sup>1</sup>Mukhachev A.P., <sup>2</sup>Yelatontsev D.O.

<sup>1</sup>M.S. Poliakov Institute of Geotechnical Mechanics of the National Academy of Sciences of Ukraine, <sup>2</sup>Dniprovsk State Technical University of MSE of Ukraine

**Abstract.** The main disadvantage of conventional suspension filtration is the slowing down of the process due to the increased pressure drop caused by the growth of the sediment on the filter medium. The issue of mechanical pressing of the sediment in the so-called filters with variable chamber which are used relatively recently to reduce the moisture content during filtration of the sediment, has not yet been resolved. The solids are deposited in the form of a sediment on the rising side of the filter medium chamber. One of the promising technologies for the separation of liquid suspensions is filtration by press filters under pressure or vacuum. Disc press filters are efficient economical equipment, in which a high level of automation of production processes is achieved with the help of modern methods. Press filters are in demand at coal preparation plants, and in metallurgical, chemical, food, and construction industries. Specialists of uranium mining companies make every effort to ensure that the filtering equipment, in addition to the above-mentioned characteristics, also has such features as low energy consumption, high productivity, easy controllability, and meets the standards of environmental safety. The article presents the results of industrial tests of mechanized disk press filters under pressure designed for filtration of suspensions, including high viscosity. The tests of the disk press filter were conducted with production suspensions, and phosphate-nitrate suspensions after dissolution of collective uranium chemical concentrate in nitric acid. It is shown that the proposed disk press filter has the following advantages: simplicity and reliability in operation; compactness; cost is less than that of the disk press filter; weight is twice less than that of analogs; all labor-intensive operations are automated; personnel working conditions meet sanitary and hygienic requirements; labor productivity is much higher than when working on a filter press due to the possibility of servicing several apparatus by one worker. The proposed disk filter press has 2.0–2.5 times higher productivity than the standard frame filter press, which allows for a reduction of 3–4 times the time for auxiliary operations. The maximum specific productivity of the filter by filtrate was 0.55 m<sup>3</sup>/m<sup>2</sup> per hour. It is noted that in case of necessity, the achieved indicators can be improved by increasing the specific flow rate of washing liquid. Thus, the press filter of the proposed design can be recommended for implementation in uranium mining and processing enterprises in Ukraine.

**Keywords:** suspension, filter, pressure, collective chemical concentrate, economic performance.

### 1. Introduction

The separation of the liquid-solid system using porous partition is the main process in the production of flotation concentrates of non-ferrous metals, iron ore concentrate, and coal [1]. In the uranium and rare-earth industry, this process has two purposes: obtaining concentrate sediments with minimum moisture (5–15%) at the filtration of dense pulps, with the minimum content of solid phase at separation of acid suspensions to use them in centrifugal extractors. To solve the problems of the first direction, a large amount of filtering equipment was created, which is not suitable for the tasks of the second direction. For this purpose, filters operating under discharge or pressure are used.

In the uranium industry, vacuum carousel precoat filters with a filtration area of 50 m<sup>2</sup> are used. For the separation of neutral non-toxic salt suspensions disk vacuum filters are used for the filtration of suspensions with densities up to 1700 kg/m<sup>3</sup> to obtain filtrates as raw material for sodium nitrate production. Lavsan and belting fabrics are used as material partitions, which quickly wear out when working under vacuum. This leads to the increase of the solid phase in the filtrate up to 1 g/l, which requires control filtration, which is carried out with the help of press filters operating under overpressure [2].

Filter-presses allow obtaining filtrates with a content of solid phase less than 100 mg/l, which satisfies the requirements for solutions during the extraction separation of similar elements such as niobium and tantalum, zirconium and hafnium, nickel, and cobalt. Concentrates of rare metals (U, Th, Nb, Ta, REE) contain radioactive elements ( $^{230}\text{Th}$ ,  $^{226}\text{Ra}$ ,  $^{210}\text{Po}$ ,  $^{210}\text{Pb}$ ), which are part of insoluble solid sediments that require special protection measures when handling them.

At the same time, filter presses have the following disadvantages:

- 1) the presence of labor-intensive operations of disassembly, unloading (sludge removal and filter-fabric regeneration) and assembly;
- 2) rapid wear of filter fabric;
- 3) contact of personnel with toxic substances during manual unloading of sludge.

All this significantly increases the cost of production.

Focusing on the full mechanization of filter presses leads either to insufficiently productive sediments removal or to the creation of expensive and complicated designs, for example, filter presses with mechanical sludge unloading [3], or automated filter presses with horizontal chambers (FPAKM) [4]. The latter is considerably more expensive than plate-frame filter presses (6–10 times). Testing of such filters in the production of uranium, REE, and zirconium showed that they have other disadvantages (the possibility of using rigid filter partitions is excluded, replacement of filter fabric is difficult, etc.).

Mechanized nutsch filters, disk, belt, and drum filters operating under discharge are considerably inferior to filter presses in productivity due to small filtering surfaces at the same size.

The cartridge (candle) and leaf filters working under pressure are close to filter presses because of the complexity of construction and the size of the filtration surface [5]. They have the same disadvantages, low specific capacity and complexity of construction.

To obtain pure filtrates - marketable products in the production of uranium and rare metals from media with acidity up to 450 g/l, frame press filters made of expensive corrosion-resistant steel are used [6].

The most suitable substitutes for filter presses are pressurized disk filters. Many designs of such apparatus are known, in which all operations on sediments removal are mechanized. Filters of the firms "United States Filter Company", "Durco-Enzinger" (USA), and "Gerfilco" (France) have either hydraulic or mechanical sediment removal (by string) at rotating shaft with subsequent sludge removal by screw, as well as lever gate on the opening lid [7–9]. The disadvantage of the design is no exposure of the disks for "dry" sludge removal and their convenient maintenance (replacement, checking the integrity of the filter fabric, etc.). The same disadvantage is found in similar disk filters of the American company "Shriver". The French company "Philippe" and Dutch "Verkspoor" produce similar disk filters working under pressure, with cell rollers and cast sectors [10].

A pressurized batch disk filter with a rolling body was developed, which is more convenient [11], but this filter has significant disadvantages: a shaft of double length (compared to the housing), a large distance between the disks due to the clamps for

fixing knives and counterweights installed on the shaft, resulting in large dimensions with a small filtering surface.

In some countries, disk filters operating under pressure are produced [12]. Such filters are much more complicated and expensive than batch disk filters, as they are equipped with cell rollers with distributing heads and screws for sludge removal. The suspension level in the filters is maintained by air or inert gas filling the upper half of the apparatus so that only part of the disk surface is constantly in the filtering zone. These apparatuses are inferior to filter presses and pressurized batch disk filters [13].

The task of this work was to create and test a hermetic design of an industrial pressurized filter to replace manual plate-and-frame filter presses in uranium production to provide a high-performance process of suspension separation with minimal contact of personnel with toxic compounds.

## 2. Experimental part

The pressurized batch disk press filter is a horizontally arranged cylindrical vessel (Figure 1) consisting of a body with a spherical bottom 1, and a spherical lid 2, connected by a fast-acting bayonet gate 15. Opening and closing of the gate is performed by using two hydraulic cylinders 12.

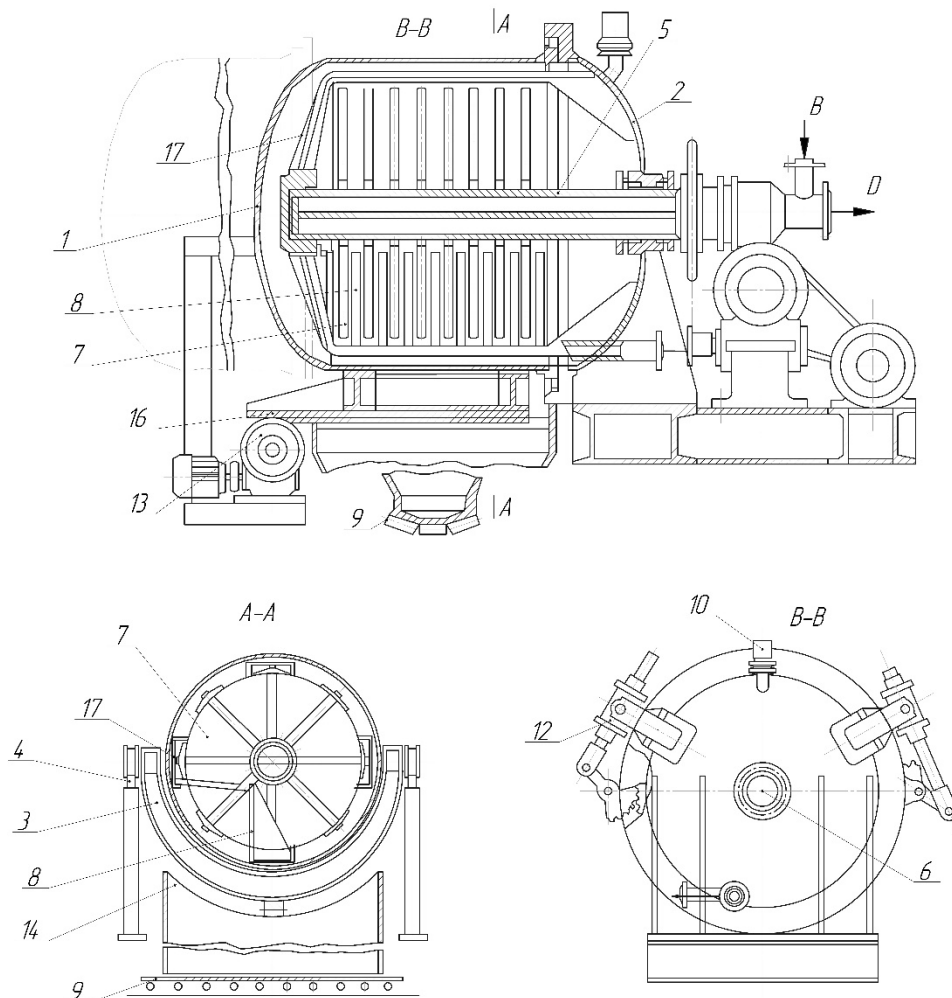

Figure 1 – Schematic diagram of a batch disk press filter

The filter body 1 is mounted on a special cart to move along the guides 4 by electromechanical drive 13 and rack and pinion transmission 16. Inside the vessel, there is a hollow shaft 5 with one longitudinal partition 6 in the middle, rotating on two supports attached to the lid 2. One shaft support is fixed directly on lid 2, and the other – is cantilevered using four beams 17, attached crosswise to the lid 2 of the filters. Disks consisting of sectors 7, onto which filter fabrics sewn to the shape of the sector are put on, are mounted on shaft 5. Sectors 7 are fixed on shaft 5 using pads and studs with nuts and can be easily removed for repair and replacement of the covers. Shaft 5 is rotated by drive 11 consisting of an electric motor, worm gearbox, and chain transmission. To remove sludge from the disks, fixed knives 8 are mounted on the lower beam 17. The acid-resistant fabric, article 2089, was used as a filter partition.

A distinctive feature of the filter is that the housing is made non-rotatable, instead of it the bayonet ring rotates, and the housing is rolled and returns to the initial position in a straight line. In this case, there is no need for a special cart, and the hydraulic cylinders, in this regard, became smaller in size, because the gear transmission between them and the body is removed. The dimensions of the hydraulic cylinders are significantly reduced for this reason and they are turned downwards, which makes them easier to service. The rubber sealing rings in the hydraulic cylinders, originally made in the form of ring toruses, are replaced by rubber sleeves, which are more reliable and durable. The distance between the disks is increased from 60 mm to 78 mm (without fabric) so that up to 4 layers of filter fabric can be used and the sludge layer can be maximized. The increased disk spacing allows for easy retrieval of unusable lids. The most effective size of the filter with a surface filtration was 25 m<sup>2</sup>; such a filter with 2–2.5 times higher specific productivity has the overall dimensions of the plate-frame filter press with a surface filtration of 56.5 m<sup>2</sup>.

Technical characteristics of the disk press filter are given in Table 1.

Table 1 – Technical characteristics of the disk press filter

Parameter	Unit	Value
1. Filtration surface	m <sup>2</sup>	9.6
2. Disc diameter	mm	850
3. Number of disks	-	10
4. Number of sectors in the disk	-	8
5. Case volume	m <sup>3</sup>	1.0
6. Working pressure in the housing	MPa	0.44
7. Rotation speed of the shaft with disks	rpm	2
8. Power of electric motors (installed): shaft drive with pulsator drive disks	kW	4.5 1.0
9. Number of pulses of the pulsator	impulse/min	120
10. Weight of filter with drive	kg	2000
11. Dimensions: - length - width - height	mm	2805 1300 1400
12. Material of parts in contact with the product		Stainless steel

To put the disk press filter into operation, the suspension supply valve A opens, which fills the vessel. In this case, the air from the vessel exits through the air valve, which automatically closes after the vessel is filled. With a further supply of the suspension from the pump, the pressure inside the vessel increases to 0.44 MPa, which is controlled by a pressure gauge, and the filtering process begins. The filtrate is discharged through a hollow shaft. When the optimal thickness of the sediment on the filter partitions of the sectors is reached, the suspension supply valve A closes, after which the pressure in the vessel drops and the filtering process stops. Then the suspension drain valve G and the valve for supplying compressed air to the vessel are opened for quickly discharge of the remained suspension from the vessel.

After emptying the vessel from the suspension, the drain valve is closed, the sediment is blown out, and the air supply stops. Hydraulic cylinders are used to open the bayonet lock and turn on the drive to roll away the cart with the filter housing. When the cart with the housing stops in the extreme position, the shaft rotation drive is turned on, and the filtrate pours from the lower sectors onto the partition inside the shaft and is discharged through the drain pipe. After one revolution of the shaft, the valve on the filtrate drain closes and the valve opens to supply pulsating air inside the hollow shaft, and as the latter continues to rotate, sediment is removed.

Instead of air, steam, water, and solutions can be supplied. After 6–7 revolutions of the shaft, the sediment is cut off with knives and falls onto the pan. Upon completion of removing sediment from the disks, the cart with the body is moved to the fixed lid, the bayonet lock is closed, and the filter is prepared for the filtering operation in the order described above.

Installation diagram. Figure 2 shows a typical connection diagram for a disk press filter. The suspension from the contact tank is pumped into the filter under pressure up to 0.44 MPa (valve A is open). Air is removed from the disk press filter housing through valve E. The filtrate is drained through valve B into the container. The filtration cycle on a disk press filter consists of the following operations: preparing the disk press filter, loading and unloading the suspension, filtering it, purging the sediment, and unloading it. Preparing the disk press filter, loading and unloading the suspension, and purging and unloading the sediment are auxiliary operations.

After the filtration process stops, the suspension is drained into the apparatus through valve G. To release the suspension, air is supplied inside the housing through valve K at a pressure of up to 0.07 MPa. To more effectively clean the disks from sediment, air from the airline with a pressure of 0.03 MPa is supplied inside the hollow shaft through pulsator G with the rate 120 pulsations per minute and through valve B. The sediment is discharged through pipeline D into contact tank 5.

Testing procedure. Using the experimental disk press filter, filtration process was tested with suspensions of uranium-containing raw materials – sediment of iron, radium, lead, polonium phosphates formed as a result of the dissolution of collective uranium chemical concentrate (CCC) in nitric acid.

After starting the disk press filter and the appearance of filtrate in the pipeline, the volume of incoming filtrate is measured every minute (within five minutes). The volume of incoming filtrate is measured every 5 minutes. In each experiment, samples

are taken to determine the physicochemical properties of the initial suspension entering the disk press filter and the filtrate. Samples to determine the solid phase content in the filtrate are taken 1 and 5 minutes after the start of filtration and at the end of the experiment. After the end of the filter cycle, the thickness of the sediment layer is measured and samples are taken to determine its moisture content. During the tests, the temperature of the initial suspension and filtrate, as well as the pressure of the suspension inside the disk press filter, air pressure at the purge and drying operands and during operation of the pulsator; duration of operations (filtration, assembly, and disassembly of the disk press filter, filling and emptying the suspension, removal of sediment with and without pulsation at different revolutions of the shaft with disks). Particular attention is paid to determining the reliability of the disk press filter, as well as the bayonet lock of the gland seals, the drive to rotate the shaft with disks, the cantilever support, bearings, and knives for removing sediment.

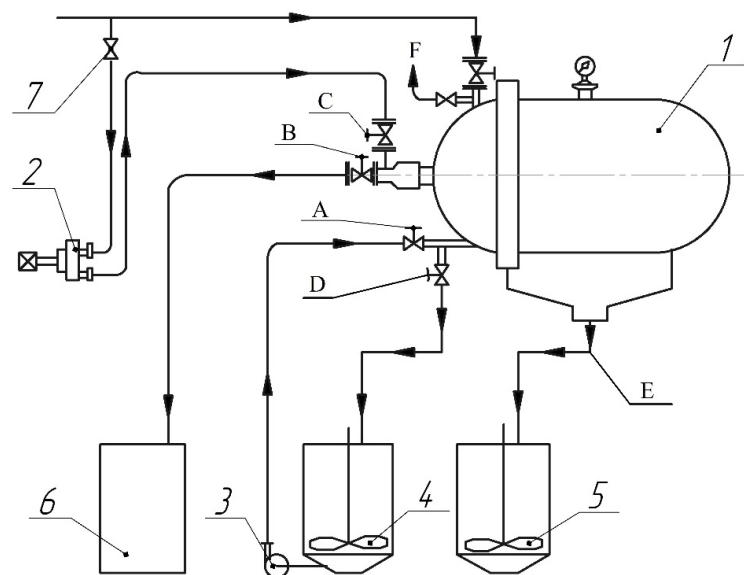

1 – press-filter; 2 – pulsator; 3 – pump; 4, 5 – contact tank; 6 – capacity; 7 – pressure reducing valve  
 A – supply of suspension; B – draining the filtrate; C – air supply inside the shaft; D – draining the suspension; E – sediment discharge; F – air discharge from the filter

Figure 2 – Installation diagram of disk press-filter

### 3. Results

An analysis of the chemical composition of the liquid phase of the suspension and the characteristics of the sediment after filtration are given in Table 2.

From the analysis data, it is clear that in the filtrate and moisture of the sediment, the uranium content reaches 9.3 g/l, which makes it harmful to personnel. The presence of isotopes ( $^{230}\text{Th}$ ,  $^{226}\text{Ra}$ ,  $^{210}\text{Po}$ ,  $^{210}\text{Pb}$ ) was also found in the filtrate, exceeding sanitary standards by 3 orders of magnitude.

The performance of batch filters is affected by the duration of each cycle. The more often the filter is recharged, the greater the filtrate yield. As the number of recharges (cycles) increases, downtime increases significantly.

Table 2 – Physicochemical properties of the studied suspensions

Trial no.	Hydro-module	Acidity, g/l		Content, g/l						Filtrate			Sediment	
		HNO <sub>3</sub>	H <sub>3</sub> PO <sub>4</sub>	P	Fe	NO <sub>3</sub> <sup>-</sup>	CaO	U	TR <sub>2</sub> O <sub>3</sub>	Density, g/cm <sup>3</sup>	Viscosity, St	t, °C	Density, g/cm <sup>3</sup>	Thickness, mm
1	1:23.5	83.6	83.3	17.0	6.96	34.9	13.0	8.91	23.76	1.175	1.312	2022	2.5	1825
2	1:30	89.2	88.2	20.42	6.61	38.2	14.4	8.98	25.0	1.185	1.35			
3	1:33	83.5	90.6	19.56	6.74	35.9	14.6	9.27	26.2	1.19	1.367			
4	1:49	103.9	71.0	19.9	6.32	35.0	15.7	9.0	26.9	1.19	1.36			
5	1:31	100.8	105.3	25.2	13.42	45.4	21.6	8.75	24.8	1.23	1.55			
6	1:33	94.0	102.9	23.2	13.42	44.8	20.3	8.35	25.1	1.228	1.54			
7	1:24	107.1	102.8	24.6	13.54	48.1	24.6	8.9	26.7	1.238	1.63			
8	1:24.5	105.0	110.2	25.2	13.31	52.2	23.5	9.0	28.2	1.238	1.59			
9	1:14.6	104.0	117.6	20.81	11.7	48.05	21.1	8.26	21.2	1.23	1.548			
10	1:17.4	163.0	194.3	20.81	11.96	46.6	24.6	8.21	19.47	1.235	1.503			
11	1:17	116.6	110.2	21.75	12.63	46.6	24.9	8.41	21.58	1.235	1.515			
12	1:11.6	77.2	129.8	23.4	11.06	48.05	24.6	8.8	31.01	1.235	1.537			
13	1:13.5	107.1	115.1	19.04	8.79	52.4	21.0	8.1	32.53	1.225	1.452			
14	1:16	103.9	115.1	19.23	8.57	52.4	21.0	8.3	28.63	1.225	1.48			

Duration of auxiliary operations was established experimentally, which is 10–11 minutes and is distributed as follows:

- 1) filling the volume of a disk press filter with a suspension at a pressure of 0.44 MPa (60–65 s);
- 2) releasing the suspension from the disk press filter at air pressure of 0.03 MPa (120–130 s);
- 3) blowing sediment off at air pressure of 0.03 MPa (110–120 s);
- 4) removing sediment at a rotation speed of the shaft with disks of 2 rpm and with the rate of pulsator 120 pulses per minute (150–200 s);
- 5) assembling the disk press filter (120 s).

The results of experiments to determine the filter performance are shown in Table 3.

As follows from the experimental data (Table 3), the highest specific productivity (m<sup>3</sup>/m<sup>2</sup> hour) for filtrate in a disk press filter is achieved regardless of the pressure and composition of the suspension with a cycle time of 28–30 minutes. Thus, for this suspension, the cycle time should be 30 minutes (20 minutes filtering, 10 minutes auxiliary operations).

The pressure difference across the filter partition was created by a centrifugal pump (rotation speed 3000 rpm, power 14 kW). According to material data [14], this increase in productivity occurs up to a certain value and then begins to fall. This limit is different for different solid:liquid (S:L) ratio, chemical properties of the suspension, and filter partition and occurs with a further increase in pressure as a result of clogging of the pores and compression of the sediment. During testing, this maximum

performance value was not reached. Currently, a working pressure of about 0.44–0.50 MPa can be recommended.

Table 3 – Determination of productivity  $\text{m}^3/\text{m}^2$  per hour for filtrate at various cycles

Test no.	Pressure, MPa	Filtration duration, min	Filtrate volume, $\text{m}^3$	Filtration surface, $\text{m}^2$	Duration of auxiliary operations, min	Number of recharges per hour	Cycle duration	Filtrate capacity, $\text{m}^3/\text{m}^2 \text{ h}$
1	0.44	5	1.2	10	10	4	15	0.48
		10	1.8			3	20	0.54
		15	2.3			2.4	25	0.55
		20	2.77			2,	30	0.55
		25	3.15			1.71	35	0.53
2	0.44	5	1.14	10	10	4	15	0.46
		10	1.65			3	20	0.49
		15	2.1			2.4	25	0.50
		20	2.55			2	30	0.51
		25	2.82			1.71	35	0.48
3	0.44	5	1.0	10	10	4	15	0.40
		10	1.46			3	20	0.44
		15	1.86			2.4	25	0.45
		20	2.25			2	30	0.45
		25	2.54			1.71	35	0.43
4	0.33	5	0.64	10	10	4	15	0.26
		10	0.96			3	20	0.29
		15	1.25			2.4	25	0.29
		20	1.46			2	30	0.29
		25	1.62			1.71	35	0.28

A reliable method for assessing the influence of physicochemical factors on the filtration process is quite difficult to develop. During tests on filtering insoluble phosphate sediment after dissolving CCC in nitric acid, it was found that the solid phase content in the suspension, in particular iron phosphate, has a noticeable effect on performance. With an increase in the solid phase content in the suspension, the filtrate productivity decreases. When filtering suspensions with the same S:L ratio, the filtrate productivity decreases with increasing iron phosphate content in the suspension.

Filter partitions are the most essential part of the filter, and the performance and purity of the resulting filtrate largely depend on their correct selection. The main requirement when choosing a filter membrane is that it must have the maximum pore size and at the same time ensure the production of a sufficiently clean filtrate. Fabric, article 2089, in one layer was used as a surface filter partition on the disk press filter.

After emptying the disk press filter from the remaining suspension, the sediment on the filter partition is blown with air with  $P = 0.03$  MPa to extract as much filtrate as possible from its pores. When the blowing time was 2 minutes, there was no significant decrease in sediment moisture. The sediment moisture content is 45–50%, which is at the level of sediment moisture content after disassembling the frame filter press. After blowing off the sediment, the disk press filter is disassembled (the bayonet lock is



opened and the cylindrical part is rolled back). The sediment formed on the surface of the disks is removed with knives (by rotating the shaft with the disks). Initially, sediment was removed from the surface of the sectors by rotating the disks at a speed of 1 rpm. In this case, satisfactory cleaning of the surface of the sectors from sediment took place in 8–12 minutes. For quicker remove of sediment from the surface of the sectors, the number of revolutions of the shaft with disks was increased to 2 rpm and a pulsator was installed (the number of pulses per minute was 120). Increasing the number of revolutions of the shaft with disks and installing a pulsator made it possible to reduce the time for cleaning the surface of the sectors from sediment to 3.0–3.5 minutes.

In the process of testing the disk press filter, sufficient reliability of operation was established, both of the disk press filter itself as a whole and of its components (except for the design of the knives and pressure pads of the sectors, the design drawbacks of which were eliminated later). A bayonet lock and gland seals ensured the tightness of the apparatus at the maximum operating pressure of the suspension inside the apparatus. The shaft rotation drives and the cantilever support of the shaft with disks ensured normal operation during the testing process. No noticeable wear was detected during the test period (1 year) of the studied units.

The maximum specific filtrate productivity on the experimental disk press filter was  $0.55 \text{ m}^3/\text{m}^2$  per hour. The distinctive features of this experiment were: maximum pressure  $P = 0.44 \text{ MPa}$ ,  $S:L = 1:49$ , and minimum content of Fe compounds. The minimum productivity for filtrate is  $0.34 \text{ m}^3/\text{m}^2$  hour (pressure  $P = 0.44 \text{ MPa}$ ,  $S:L = 1:24$ , CaO content –  $24.6 \text{ g/l}$  and Fe content –  $13.5 \text{ g/l}$ . At when filtering the same suspensions on a frame filter press, the filtrate productivity was  $0.18\text{--}0.20 \text{ m}^3/\text{m}^2$  per hour.

Thus, studies of the separation of uranium-containing suspensions on a disk-press filter shown that the developed design of the apparatus provides high productivity with a significant reduction in the time of personnel contact with radioactive isotopes. The proposed design of the disk filter press has 2.0–2.5 times greater productivity than frame filter presses.

After successful testing of the pilot industrial sample of the disk press filter, several large-sized industrial filters were developed, in which the drawbacks of the prototype were eliminated. Filters with filtration areas of  $5 \text{ m}^2$ ,  $10 \text{ m}^2$ ,  $25 \text{ m}^2$  and  $45 \text{ m}^2$  were developed. A filter with a filtration area of  $25 \text{ m}^2$  has the dimensions of a frame filter press with an area of  $56.5 \text{ m}^2$ . A filter with a filtration area of  $45 \text{ m}^2$  has the dimensions of a frame filter press with an area of  $84 \text{ m}^2$ .

#### 4. Conclusions

1. The mechanized disc press filter of periodic action, operating under pressure up to  $0.5 \text{ MPa}$ , with pulsation blowing and knives for removing sediment, was proposed and tested. The apparatus is easy to maintain and manufacture, reliable in operation, its entire operating cycle can be fully automated. During production tests of the disk press filter on uranium suspensions, the optimal parameters of its operation (cycle time, pressure) were established.

2. Tests shown that the disk filter press has 2.0–2.5 times greater filtrate productivity than the frame filter press, which allows reducing the time for auxiliary operations by 3–4 times.

3. Labor productivity per worker when working with the disk filter press is higher than with filter press due to the increased filter productivity and the possibility of servicing several apparatus by one person, thus, reducing cost of physical labor.

4. The working conditions for the personnel are in full compliance with sanitary and hygienic requirements: during the filtration process, the apparatus is located in a hermetically sealed room; the filtrate is drained from the disk press filter through a pipeline; the time a disk press filter staying opened is shorter compared to a filter press due to the mechanization of such operations as filter opening and closing and sediment removing.

5. The disk press filter was tested in the production of uranium from the uranium-phosphorus-rare earth concentrate.

6. The disk filter press is recommended for replacing plate-frame filter presses in the technology of processing uranium-containing and rare metal raw materials that contain radioactive elements.

*A.I. Skripin, V.A. Yakovlev, V.I. Vyazankin, I.G. Tsybenko, the employees of the "Pridneprovsky Chemical Plant" (PChP) took part in the work.*

#### REFERENCES

1. Rao, K. A., Patel, A. B., Gujral, M., Karan, R., Kumar, M. A., Serajuddin, M., and Sreenivas, T. (2022), "Development and Scale-up of Chemical Process for Conversion of Impure Sodium Diuranate to Uranium Peroxide", *Journal of the Geological Society of India*, no. 8, pp. 1145-1151. <https://doi.org/10.1007/s12594-022-2136-5>
2. Sorrentino, G., and Biscontin, G. (2023), "Improved filtration parameters from modified API filter press", *Geoenergy Science and Engineering*, no. 224, art. no. 211605. <https://doi.org/10.1016/j.geoen.2023.211605>
3. Fränkle, B., Morsch, P., Kessler, C., Sok, T., Gleiß, M., and Nirschl, H. (2022), "Iron Ore Tailings Dewatering: Measurement of Adhesion and Cohesion for Filter Press Operation", *Sustainability*, no. 6, art. no. 3424. <https://doi.org/10.3390/su14063424>
4. Serajuddin, M., and Mukhopadhyay, S. (2022), "Influence of rheology in the filtration of leach slurry generated by alkaline pressure leaching of a limestone ore", *Cleaner Chemical Engineering*, no. 4, art. no. 100079. <https://doi.org/10.1016/j.clce.2022.100079>
5. Neikov, O.D. (2019), "Processing of Powders and Processing Equipment", in Neikov, O.D., Naboychenko, S.S. and Yefimov, N.A. (eds.), *Handbook of Non-Ferrous Metal Powders. Technologies and Applications (Second Edition)*, Elsevier Ltd., Amsterdam, Netherlands, pp. 403-455. <https://doi.org/10.1016/B978-0-08-100543-9.00014-2>
6. Patil, S. V., and Thorat, B. N. (2022), "Mechanical dewatering of red mud", *Separation and Purification Technology*, no. 294, art. no. 121157. <https://doi.org/10.1016/j.seppur.2022.121157>
7. Basfar, S., Al Jaber, J., Elkhatny, S., and Bageri, B. S. (2022), "Prevention of hematite settling using perlite in water-based drilling fluid", *Journal of Petroleum Science and Engineering*, no. 210, art. no. 110030. <https://doi.org/10.1016/j.petrol.2021.110030>
8. Bageri, B., Al Jaber, J., Siddig, O., Adebayo, A. R., and Elkhatny, S. (2022), "Improving filter cake sealing properties for high-density ilmenite drilling fluid", *Journal of Petroleum Science and Engineering*, no. 218, art. no. 111057. <https://doi.org/10.1016/j.petrol.2022.111057>
9. Voit, D., Johnson, M., and Maki, D. (1995), "Hafnium hydroxide filtration, expression, and washing" *Minerals Engineering*, no. 1-2, pp. 179-189. [https://doi.org/10.1016/0892-6875\(94\)00112-P](https://doi.org/10.1016/0892-6875(94)00112-P)
10. Fränkle, B., Morsch, P., and Nirschl, H. (2021), "Regeneration assessments of filter fabrics of filter presses in the sector", *Minerals Engineering*, no. 168, art. no. 106922. <https://doi.org/10.1016/j.mineng.2021.106922>
11. Chhabra, R. and Basavaraj, M.G. (2019), "Liquid Filtration", *Coulson and Richardson's Chemical Engineering, Volume 2a: Particulate Systems and Particle Technology (Sixth Edition)*, Elsevier Ltd., Amsterdam, Netherlands.
12. Wakeman, R. J., and Tarleton, E. S. (1994), "A framework methodology for the simulation and sizing of diaphragm filter presses", *Minerals Engineering*, no. 11, pp. 1411-1425. [https://doi.org/10.1016/0892-6875\(94\)00079-4](https://doi.org/10.1016/0892-6875(94)00079-4)
13. Jia, R., Zhang, B., He, D., Mao, Z., and Chu, F. (2020), "Data-driven-based self-healing control of abnormal feeding conditions in thickening - dewatering process". *Minerals Engineering*, no. 146, art. no. 106141. <https://doi.org/10.1016/j.mineng.2019.106141>

14. Yelatontsev, D.A., Mukhachev, A.P., Kharitonova, E.A., and Nefedov, V.G. (2021), "Development and industrial implementation of an economic scheme for extracting uranium from the iron ore of the «Pervomayskoye» deposit", *Bulletin NAGN*, no. 14, pp. 6–15.

---

#### About the authors

**Mukhachev Anatolii Petrovych**, Candidate of Physics and Mathematics (Ph.D.), Senior Researcher in Department of Vibratory Transporting Systems and Complexes, M.S. Poliakov Institute of Geotechnical Mechanics of the National Academy of Sciences of Ukraine (IGTM of the NAS of Ukraine), Dnipro, Ukraine, [map45@ukr.net](mailto:map45@ukr.net)

**Yelatontsev Dmytro Oleksandrovych**, Candidate of Technical Sciences (Ph.D.), Associate Professor in Department of Chemical Technology of Inorganic Substances, Dnipro State Technical University of the Ministry of Education and Science of Ukraine (DSTU of MES of Ukraine), Kamianske, Ukraine, [sauron11652@gmail.com](mailto:sauron11652@gmail.com)

### ПРЕС-ФІЛЬТР ДИСКОВОГО ТИПУ ТА ЙОГО ПРОМИСЛОВЕ ВИПРОБУВАННЯ

*Мухачев А.П., Єлатонцев Д.О.*

**Анотація.** Головним недоліком традиційної фільтрації суспензій сповільнення процесу через збільшення перепаду тиску, спричиненого зростанням осаду на фільтруючому середовищі. Питання механічного віджимання осаду в так званих фільтрах зі змінною камерою, які використовуються відносно недавно для зниження вмісту вологи при фільтрації осаду, досі не вирішено. Тверді частинки осаджуються у вигляді осаду на висхідній стороні камери фільтруючого матеріалу. Однією з найбільш перспективних технологій поділу рідких зависей (суспензій) є фільтрація прес-фільтрами під надлишковим тиском або під вакуумом. Діскові прес-фільтри – це ефективне, економічне устаткування, у якому з допомогою сучасних методів досягається високий рівень автоматизації виробничих процесів. Прес-фільтри потрібні на вугільних збагачувальних фабриках, у металургійній, хімічній, харчовій, будівельній промисловості. Фахівці уранодобувних компаній докладають усіх зусиль для того, щоб фільтруюче обладнання, крім перерахованих вище характеристик, мало також такі характеристики, як низька енергоємність, висока продуктивність, легка керованість, відповідає стандартам екологічної безпеки. У статті наведено результати промислових випробувань механізованого дискового прес-фільтра під тиском, призначеного для фільтрації суспензій, у тому числі великої в'язкості. Випробування дискового прес-фільтра проводилися на виробничих суспензіях, фосфатно-нітратних пульпах після розчинення колективного хімокцентрату урану (КХК) в нітратній кислоті. Показано, що запропонований дисковий прес-фільтр має такі переваги: простота та надійність у роботі; компактність; менша, ніж у дискового прес-фільтра, вартість; удвічі менша, ніж у стандартних фільтрів, вага; всі трудомісткі операції автоматизовані; умови роботи персоналу відповідають санітарно-гігієнічним вимогам; продуктивність праці значно вища, ніж при роботі на фільтр-пресі у зв'язку з можливістю обслуговування одним робітником кількох апаратів. Запропонований дисковий фільтр-прес має в 2,0–2,5 рази більшу продуктивність, ніж стандартний рамний фільтр-прес, що дозволяє скоротити в 3–4 рази час на допоміжні операції. Максимальна питома продуктивність фільтра за фільтратом становила 0,55 м<sup>3</sup>/м<sup>2</sup> год. Зазначено, що у разі потреби досягнуті показники можуть бути підвищені за рахунок збільшення питомої витрати промивної рідини. Таким чином, прес-фільтр запропонованої конструкції може бути рекомендований для впровадження на уранодобувних та гірничозбагачувальних підприємствах України.

**Ключові слова:** суспензія, фільтр, тиск, колективний хімічний концентрат, економічні показники.