

UNIVERSAL HYDROPNEUMATIC SHOCK ABSORBER FOR DRILL COLUMN

¹Antonchik V., ²Hankevych V., ¹Maltseva V., ³Pashchenko O., ¹Minieiev S.,
³Kiba V., ⁴Livak O., ³Velihina N.

¹M.S. Poliakov Institute of Geotechnical Mechanics of the National Academy of Sciences of Ukraine

²Branch for Physics of Mining Processes of the M.S. Poliakov Institute of Geotechnical Mechanics of the National Academy of Sciences of Ukraine

³Dnipro University of Technology

⁴Ukrainian State University of Science and Technologies

Abstract. This article addresses the protection of drill column and drilling equipment from mechanical vibrations transmitted from the drilling bit during rock drilling. Axial and tangential vibrations can exceed the axial feed force by four times, and their frequency can be three times higher than the rotation frequency of the drill bit. These fluctuations can lead to equipment wear, improper hole formation, reduced work safety, and decreased overall productivity of drilling operations. Therefore, understanding the issue and implementing a vibration control system are crucial for achieving optimal productivity and ensuring safety in drilling operations.

The purpose of this article is to develop a shock absorber that reduces forces from both axial and tangential vibrations of the drilling pond during rock drilling, whether using roller bits or cutters.

To achieve this goal, an analysis of known methods and mechanisms for damping these vibrations was conducted, considering both the axial pressure of the drilling tool on the bottomhole and the torque applied to the drilling tool. The shortcomings of existing devices for damping axial and circumferential vibrations were identified. The duration of the bottomhole pulse impact and the duration of the full cycle of oscillations of the bit and shock absorber resulting from compression and expansion of the spring were calculated. It was determined that the shock absorber prolongs the duration of the bottomhole impulse, smoothly increasing and decreasing the force from the axial load. The article explores means of damping mechanical vibrations in drilling equipment and suggests potential avenues for development. A design for a universal hydropneumatic shock absorber was developed to maximize damping of both axial and circumferential vibrations, suitable for drilling with both ball bits, where significant axial load predominates, and cutting bits, where significant torque is applied along with the axial load. The advantages of this hydropneumatic shock absorber's operation method and its ability to work using both compressed air and liquid pressure for vibration damping and removal of debris are described."

Keywords: hydropneumatic shock absorber, drill column, drilling bit, longitudinal and tangential vibrations, elastic element.

1. Introduction

In modern deep well drilling, one of the key factors affecting efficiency and work quality is the damping of vibrations that occur during the drilling process. During drilling, the drilling rod and drilling tools are subjected to axial and tangential vibrations [1, 2]. Axial vibrations occur due to the back reaction of rocks during drilling, as well as uneven loading on the rod, while tangential vibrations occur due to the uneven distribution of force during the rotation of the drilling tool. These oscillations can lead to equipment wear, incorrect hole formation, reduced safety, and a decrease in overall drilling performance. Therefore, understanding the problem and applying a vibration control system is critical for achieving optimal productivity and safety in drilling operations.

Protecting the drill column and drilling rigs from axial and tangential vibrations, which can exceed the axial feed force by four times and whose frequency can be three times higher than the drilling bit rotation speed [2], is crucial for increasing drilling productivity and quality. Effective oscillation damping can yield the following benefits:

- Equipment safety. Vibration protection helps reduce wear and tear of the drilling rod and drilling tools, keeping the equipment in working order and reducing the cost of repair and replacement of parts.

- Improved drilling quality. Reduced vibrations contribute to more accurate and uniform hole formation, allowing for better results and ensuring correct geological survey of the underground layers.

- Increased safety. Oscillations can pose dangers to workers, especially at high amplitudes and speeds. Vibration protection helps mitigate the risk of accidents and fosters a safer working environment.

- Higher productivity. It is achieved through oscillation protection, which reduces the time required for drilling. Additionally, fewer interruptions due to breakdowns and the need to replace parts contribute to this increased productivity.

Currently, two main types of devices installed between the drilling tool and the drill column are used to combat harmful mechanical vibrations of the drilling tool and the drill column: mechanical and hydraulic or pneumatic shock absorbers.

Mechanical shock absorbers use various elastic elements, springs, rubber, and others to combat harmful vibrations, which receive shock impulses on the bit from the bottomhole, change these impulses, partially dampen them, and transmit them to the drill column.

The well-known designs of hydraulic or pneumatic dampers also work according to this scheme, but with different processes of damping and transmission of vibrations to the drill column.

Both mechanical shock absorbers and hydropneumatic dampers have a number of disadvantages. The most widespread are mechanical shock absorbers, the use of which can increase the drilling speed by 15-25% [1-3] and the service life of bits by 20-40% [1-3]. Despite this, mechanical shock absorbers with elastic elements in the form of steel springs have a number of disadvantages. Let's consider these disadvantages: during drilling, the drilling bits are subjected to the rock reaction force from the bottomhole side (when the bit teeth are deepened into it) in the form of short but significant force pulses, which are subsequently transmitted to the drill column and drilling machines, creating longitudinal axial and circumferential vibrations. Since both axial force and torque are jointly involved in the process of rock destruction, the reaction from the rock can be 4 times higher than the specified axial load and 3 times (for three-cone bits) the rotation speed of the drilling tool [2].

The detrimental impact on drilling tools and equipment stems from the rapid transfer of impulse from the bottomhole to the tool. Modern mechanical shock absorbers, incorporating an elastic element such as a spring, prolong the duration for the impact load to reach the bit, thereby mitigating its adverse effects.

2. Methods

Let's examine the impact loading process from the bottomhole onto the drilling bit and its duration using the example of the bottomhole shock absorber SBSH-200, designed for drilling wells with roller bits.

Assuming that the axial force of the bottomhole reaction surpasses the specified axial force by four times and the pulse frequency from the bottomhole side is three times higher than the bit rotation frequency, the impulse from the bottomhole to the drilling bit is converted into the kinetic energy of the drilling bit

$$K_{id} = \frac{m \cdot V^2}{2}, \quad (1)$$

where K_{id} – is the kinetic energy of the drilling bit and shock absorber from the impulse J , and V – is the initial velocity of the mass m , m/s.

$$m = m_g + m_a,$$

where m - is the weight of the drilling bit and the shock absorber part, kg; m_g – is the weight of the drilling bit, kg; and m_a – is the weight of the shock absorber, kg.

The shock absorber spring breaks the upward movement of the drilling bit and shock absorber, bringing it to a complete stop. In the process, it performs work equal to the kinetic energy of the drilling bit. The spring's work is equal to:

$$A_{np} = K_{id}, \quad (2)$$

$$A_{np} = \int_{x_1}^{x_2} F_y(x) \cdot dx = \int_{x_1}^{x_2} kx \cdot dx, \quad (3)$$

where F_y – is the spring elasticity force, N.

$$F_y = kx, \quad (4)$$

where k – spring elasticity, N/m; x – is the value of spring deformation, m.

Substituting (1) into (2) and (4) into (3), we get:

$$\int_{x_1}^{x_2} kx \cdot dx = \frac{mV^2}{2}, \quad (5)$$

or, integrating the left-hand side of the equation gives us,

$$kx^2 = mV^2,$$

therefore

$$V = \sqrt{\frac{k}{m} x^2} = x \sqrt{\frac{k}{m}}. \quad (6)$$

Let's represent V as, $\frac{dx}{dt}$, where t is the time, s. Then

$$\frac{dx}{dt} = x\sqrt{\frac{k}{m}},$$

and solve for « t »

$$dt = \frac{1}{\sqrt{\frac{k}{m}}} \frac{dx}{x}. \quad (7)$$

By integrating, we get

$$\int_0^t dt = \frac{1}{\sqrt{\frac{k}{m}}} \int_{x_2}^{x_1} \frac{dx}{x}, \quad (8)$$

$$t_c = \frac{1}{\sqrt{\frac{k}{m}}} (\ln x_2 - \ln x_1). \quad (9)$$

By substituting the values k, m, x_1, x_2 into (9)

$$k = \frac{F_n}{x_1} = \frac{250 \text{ kN}}{0,005 \text{ m}} = 50 \cdot 10^6 \text{ N/m},$$

where F_n – is the axial force equal to 250 kN; x_1 – is the pre-strain, m; $x_1 = 0,005$ m;
 x_2 – maximum strain, m; $x_2 = 0,02$ m.

$$\sqrt{\frac{k}{m}} = \sqrt{\frac{50 \cdot 10^6}{2 \cdot 10^2}} = 5 \cdot 10^2 \frac{1}{\text{s}} = \frac{1}{500} = 2 \cdot 10^{-3}.$$

This gives us:

$$t_c = 2 \cdot 10^{-3} [-3,912 - (-5,298)] = 2,77 \cdot 10^{-3} \text{ s},$$

where t_c – is the shock absorber spring compression time, s.

$$t_c = t_p = 2,77 \cdot 10^{-3} \text{ s},$$

where t_p – is the time of the shock absorber spring tensile, s.

Duration of the bottomhole reaction pulse in integral form:

$$F_p \cdot t_i = mV, \quad (10)$$

where F_p – is the face reaction which is 4 times higher than the axial load, H; t_i – is the duration of a bottomhole pulse.

The speed of the bit and shock absorber is determined from (6)

$$V = 2 \cdot 10^{-2} \cdot 5 \cdot 10^2 = 10 \text{ m/s.}$$

Then

$$t_i = \frac{mV}{F_p}, \quad (11)$$

$$F_p = 4F_n = 4 \cdot 250 \text{ kN} = 1000 \text{ kN},$$

$$F_p = F_{\max} = 10^3 \text{ kN},$$

where F_{\max} – maximum force from the reaction of the bottomhole, N.

This gives us

$$t_i = \frac{200 \cdot 10}{1000 \cdot 10^3} = 2 \cdot 10^{-3} \text{ s.}$$

If we compare the duration of the bottomhole reaction pulse $t_i = 2 \cdot 10^{-3}$ and the time of the full cycle of oscillations of the drilling bit and shock absorber as a result of compression and expansion of the spring, the action of the shock absorber increases the duration of the bottomhole reaction pulse by 2.77 times $\left(\frac{t_{II}}{t_I}\right)$, gradually increasing the force from F_n to F_{\max} and decreasing from F_{\max} to F_n .

3. Results and discussion

However, mechanical shock absorbers with an elastic element in the form of a spring also have disadvantages. The load on the bit, although increasing gradually, reaches values up to four times higher than the specified axial load. This necessitates

a fourfold safety margin for all parts and mechanisms of the bit, drill column, and drilling rigs, significantly increasing the weight and cost of drilling equipment.

Shock absorbers with elastic elements in the form of rubber are not widely used. This is attributed to the properties of rubber itself, which exhibit residual deformations and fail to return to their original shape. Consequently, under frequent alternating loading, rubber quickly loses its elastic properties and deteriorates.

Hydraulic and pneumatic dampers also possess several drawbacks, limiting their widespread usage. For instance, pneumatic dampers necessitate a high-pressure compressed gas chamber to generate the supply pressure and counteract bottomhole reaction pulses. However, the relatively small end surface area of this chamber, determined by the diameter of the borehole, poses challenges. This results in the need to seal the moving parts of the chamber (such as the piston), which are prone to wear and lead to air leaks, decreasing chamber pressure and compromising shock absorber properties. Furthermore, gas compression within a closed volume significantly increases pressure, transmitting force, albeit smoothly, to the drilling bit, often exceeding the feed force by 3–4 times.

Similarly, hydraulic shock absorbers share the aforementioned disadvantages with pneumatic ones. Additionally, the presence of fluid complicates the design without contributing significant elasticity, as the compression of fluid in a small closed volume is minimal.

Thus, existing shock absorber designs merely prolong harmful vibrations rather than eliminating them altogether.

The objective of this study is to develop a shock absorber capable of mitigating forces resulting from both axial and tangential vibrations of the drill column, whether equipped with roller bits or cutters.

This shock absorber was devised based on the principle of dampening harmful vibrations using a substantial volume of compressed air or liquid within the drill column. It serves the purpose of removing rock fracture products during drilling.

Figures 1 and 2 show the universal hydropneumatic shock absorber for drill column.

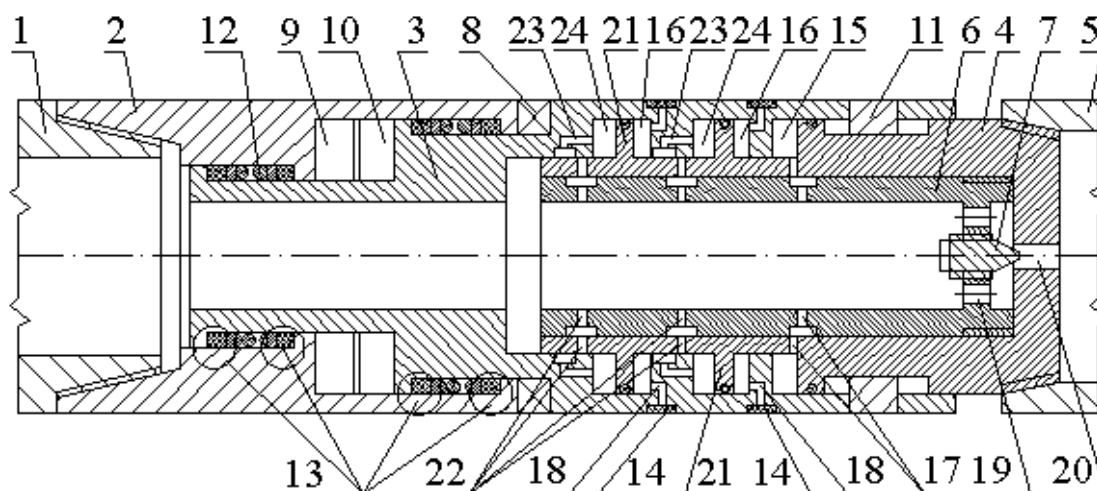

Figure 1 – Universal hydropneumatic shock absorber for drill column

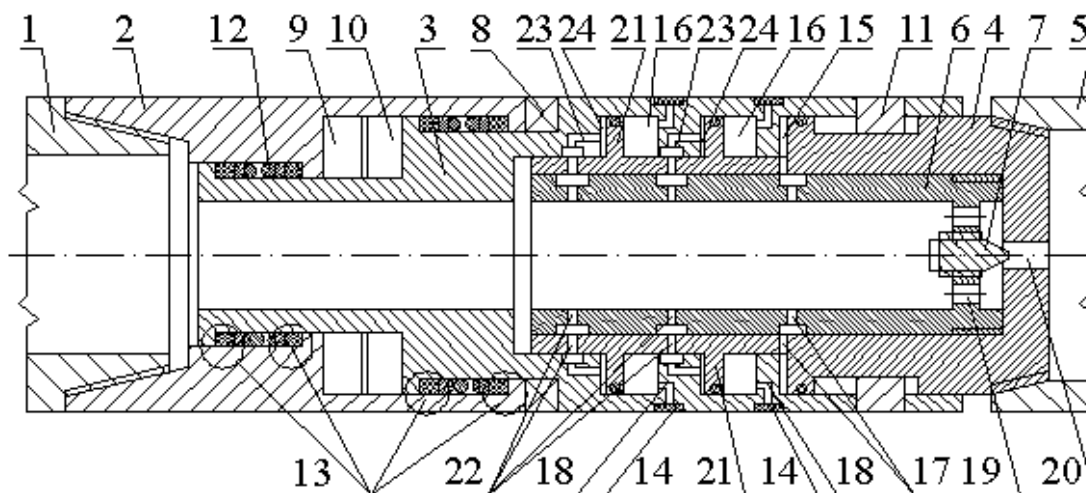

Figure 2 – Universal hydropneumatic shock absorber for drill column in a closed condition.

The universal hydropneumatic shock absorber for drill column is consisting of: 1 – drill column; 2 – hydraulic clutch housing, 3 – cylinder; 4 – stem; 5 – drilling bit; 6 – sleeve; 7 – adjusting screw; 8 – bearing; 9 – driving blades; 10 – trailing blades; 11 – key; 12 – spring; 13 – gland packing unit; 14 – filter; 15 – high pressure chamber; 16 – atmospheric pressure chamber; 17 – channels of constant action; 18 – atmospheric channels; 19 – exhaust holes; 20 – outlet channel; 21 – cylindrical protrusions–pistons of the stem; 22 – braking action channels; 23 – liquid or gas supply channels; 24 – high-pressure brake chambers.

The universal hydropneumatic shock absorber for drill column operates as follows. The hydraulic clutch housing (2), is threaded onto the drill column (1), while the drilling bit (5) is attached to the stem (4) of the hydropneumatic shock absorber. Initially, the adjusting screw (7) within the sleeve (6) is positioned by rotating it in the thread to achieve the desired pressure of gas or liquid within the sleeve (6) and drill, necessary for the hydropneumatic shock absorber's operation at a given flow rate. Gas or liquid exits the shock absorber through the exhaust holes (19) and the outlet channel (20). The end surface area of the pneumatic cylinder stem (4) within the rightmost high-pressure chamber (15) is designed to ensure that the working pressure of the liquid or gas acting on this surface provides the calculated force required to press the drilling bit against the bottomhole.

A hydropneumatic shock absorber with a drilling bit (5) is mounted on the surface of the bottomhole. Gas or liquid is supplied to the drill column (1) to remove rock debris. Gas or liquid enters the high-pressure chamber (15) closest to the drilling bit (5) through the channels of constant action (17), pressing the drilling bit against the bottomhole with the required force (refer to Fig. 1). Subsequently, torque is applied to the drill column (1) and transmitted to the hydraulic clutch housing (2), which, supported by the bearing (8), attains the necessary revolutions alongside the driving blades (9) within the hydraulic clutch chamber (2). This chamber is filled with liquid lubricant and sealed with gland packing (13) and springs (12). The driving blades (9) generate dynamic pressure on the trailing blades, firmly attached to the cylinder (3),

thereby transmitting torque to the cylinder (3). This torque is then conveyed through the key (11) to the stem (4) and ultimately to the drilling bit (5) (refer to Fig. 1). The keyway in the stem (4) is threaded longer than the key (11), ensuring continuous transmission of torque to the rod and bit even during axial vibrations. Tangential vibrations of the drilling bit (5) occurring during cutting are dampened by turbulent mixing of the liquid lubricant in the hydraulic clutch. During drilling, the rock reaction impulse generates a force on the bottomhole, pushing the drilling bit (5) and the shock absorber stem (4) towards the drill column (1), causing axial vibrations of the drill column. Initially, the drilling bit and stem (4) are braked by the pressure of gas or liquid in the high-pressure chamber (15). Then, the braking action channels (22) connect to the liquid or gas supply channels (23), allowing gas or liquid to enter the high-pressure brake chambers (24). Subsequently, the drilling bit (5) and stem (4) are braked by the pressure of the liquid or gas in three chambers: two high-pressure brake chambers (24) and one high-pressure chamber (15), which remains connected to the liquid or gas supply line continuously. Under the pressure from the three chambers, the drilling bit (5) and the stem (4) quickly come to a stop. Due to the pressure difference between the high-pressure chambers (15 and 24) and the atmospheric pressure chambers (16), connected to the atmosphere via atmospheric channels (18) through the filter (14), an unbalanced force acts on the cylindrical protrusions-pistons of the stem (21) toward the bottomhole. This force arises from the high-pressure brake chambers (24) and the high-pressure chamber (15), moving the drilling bit (5) back to its starting position.

About 2–3 mm before reaching the starting position, the liquid or gas supply channels (23) close, halting the flow of liquid or gas into the high-pressure brake chambers (24), and the drilling bit (5) comes to a stop on the surface of the bottomhole. However, the flow of liquid or gas into the high-pressure chamber (15) continues, providing the necessary feed force to the drilling bit (5) (refer to Fig. 1).

Let's now examine the process of moving the stem (4) under the influence of the bottomhole reaction impulse until it stops due to the pressure of the liquid or gas in the design of the hydropneumatic shock absorber.

We'll calculate the process of stopping the shock absorber stem (4) based on the previously determined mass and kinetic energy of the bit and shock absorber, obtained as a result of the bottomhole reaction during drilling. The work done by the liquid or gas pressure force is equal to the kinetic energy of the bit and shock absorber.

$$A = \frac{m \cdot V^2}{2}, \quad (12)$$

where A – is the operation of the pressure force in high pressure chambers, J; V – is the initial speed of the bit and shock absorber, m/s; $V = 10$ m/s.

$$A = \int_0^x F_d \cdot dx, \quad (13)$$

where F_d – is the mass braking force « m » inside the hydraulic shock absorber, N;
 $m = 200$ kg.

$$\int_0^x F_d(x) \cdot dx = \frac{m \cdot V^2}{2}, \quad (14)$$

$$F_d = \frac{mV^2}{2}, \quad (15)$$

where $F_d = 3F_n = 3 \cdot 250 = 750$ kN.

$$x = \frac{mV^2}{2F_d}, \quad (16)$$

$$x = \frac{200 \cdot 10^2}{2 \cdot 750 \cdot 10^3} = 0,013 \text{ m},$$

where x – is the stem 4 path to stop, m. 3 (16) we get

$$V = \sqrt{\frac{2F_d}{m} x} \quad (17)$$

Let's represent V as $\frac{dx}{dt}$ and, substituting in (17), we get

$$\frac{dx}{dt} = \sqrt{\frac{m}{2F_d} x} \quad (18)$$

$$\frac{dx}{dt} = \sqrt{\frac{m}{2F_d}} \frac{dx}{\sqrt{x}}, \quad (19)$$

$$\int_0^t dt = \sqrt{\frac{m}{2F_d}} \int_0^x \frac{dx}{\sqrt{x}}.$$

By integrating (19), we get

$$t_T = 2 \sqrt{\frac{m}{2F_d}} \sqrt{x}, \quad (20)$$

Substituting the values m , F_d , x we get

$$\sqrt{\frac{m}{2F_d}} = 0,0115,$$

$$t_T = 2\sqrt{\frac{200}{2 \cdot 750 \cdot 10^3}} \sqrt{0,013} = 0,0026,$$

where t_T – is stem 4 braking time, s.

The deceleration and acceleration times of the stem 4 are the same, since the same force is applied.

$$t_T = t_O = 2,6 \cdot 10^{-3},$$

where t_O – is the return stroke time, s.

$$t_C = t_T + t_O = 2 \cdot 2,6 \cdot 10^{-3} = 5,2 \cdot 10^{-3},$$

where t_C is the oscillation cycle time of the bit and shock absorber, s.

Let's compare the frequency of the pulses of the bottomhole reaction with the time of the full cycle of oscillations of the bit with a shock absorber.

It is known [2] that the tool vibration frequency can be 3 times higher than the tool rotation frequency.

At a rotational speed of a three-cone bit of 120 min (2 s), the vibration frequency can be (6 oscillations/s). Based on this, the time between oscillations is 0.002 s.

The pulse duration of the bottomhole reaction is 0.002 s. Time between pulses is:

$$t = 0,1666 - 0,002 = 0,1646.$$

Full oscillation cycle time of the hydraulic shock absorber $t_{II} = 0,0052c$, the shock absorber operates at a frequency approximately 32 times faster than that of the bottomhole reaction pulses. This allows the bit with the shock absorber to return to the initial position on the bottomhole surface before the occurrence of the second pulse.

4 Conclusions

The universal hydropneumatic shock absorber, due to the fact that the braking of the bit occurs almost immediately, performs the same braking work as known shock absorbers with a greater force, but this force is less than the bottomhole reaction force, which reduces the required strength of the drilling equipment and its weight

(amount of metal). The universal hydropneumatic shock absorber dampens both axial and tangential vibrations and works equally well in both liquid and gas drilling with both cutters and roller bits, while the known shock absorbers are specialised for different types of drilling and their designs differ.

Based on calculations, the oscillation cycle times of a mechanical (spring) shock absorber and a universal hydropneumatic shock absorber are approximately the same, but the force transmitted by the mechanical (spring) shock absorber to the drill column is equal to $4F_n$ that is, four times the feed force, while the specified universal hydropneumatic shock absorber at the same oscillation frequency as the mechanical one transmits the maximum force to the drill column, which is equal to $3F_n$, i.e. three times the feeding force. Therefore, the proposed shock absorber reduces the maximum force (by 250 kN, in the case of the example above), resulting in a 25% reduction in the required tensile strength of the drilling equipment and its overall weight. This reduction in weight not only decreases the cost of the drilling equipment but also enhances its service life.

REFERENCES

- Ostrovsky, N.R., Siryk, V.F. and Hankevich, V.F. (2010), "Over-bit shock absorbers", *Bulletin of the National Technical University KhPI*, no. 65, pp 11–21.
- Smith, J.A. and Johnson, B.C. (2020), "Vibration Analysis and Control in Drilling Operations", *Journal of Petroleum Engineering*, no. 25 (3), pp 135–150
- Li, C. and Wang, Z. (2019), "Vibration Reduction in Drilling Equipment", A Review of Existing Technologies *International Journal of Offshore and Polar Engineering*, no. 29 (4), pp 374–385.
- Kozhevnykov, A., Khomenko, V., Liu, B., Kamyshtsky, I O., and Pashchenko, O. (2020) "The history of gas hydrates studies", *From laboratory curiosity to a new fuel alternative In Key Engineering Materials*, no. 44, pp. 49–64. <https://doi.org/10.4028/www.scientific.net/KEM.844.49>
- Chen, H. and Zhang, L. (2018), "Advances in Vibration Monitoring and Control for Drilling Rigs", *Journal of Vibration Engineering & Technologies*, no. 45 (2), pp 78–92.
- Duan, S. and Xu, Y. (2017) "Active Vibration Control for Offshore Drilling Platforms", *Challenges and Solutions Offshore Engineering*, no.34 (1), pp 56–70.
- Rahman, M. and Gupta, S. (2016), "Intelligent Vibration Control for Drilling Operations using Artificial Neural Networks", *Journal of Intelligent Systems & Robotics*, no. 20 (4), pp 212–225.
- Gao, X. and Liu, H. (2015), "Application of Smart Materials in Vibration Damping for Drilling Equipment", *Journal of Mechanical Engineering*, no 42 (3), pp 156–167.
- Wang, J. and Chen, W. (2014), "Vibration Analysis and Control of Drilling Rigs using Piezoelectric Actuators", *Journal of Sound and Vibration*, no. 38 (5), pp 290–305.
- Aarsnes, U.J.F. and Van de Wouw N. (2019), "Axial and torsional self-excited vibrations of a distributed drill-string", *Journal of Sound and Vibration*, no. 444, pp 127-151. <https://doi.org/10.1016/j.jsv.2018.12.028>
- Vromen T., Van De Wouw, N., Doris, A., Astrid, P. and Nijmeijer, H. (2017), "Nonlinear output-feedback control of torsional vibrations in drilling systems", *International Journal of Robust and Nonlinear Control*, no. 27 (17), pp 3659-3684. <https://doi.org/10.1002/rnc.3759>
- Ihnatov, A., Haddad, J., Stavychnyi, Y. and Plytus, M. (2023), "Development and Implementation of Innovative Approaches to Fixing Wells in Difficult Conditions", *Journal of The Institution of Engineers: Series D*, no. 104 (1), pp 119-130. <https://doi.org/10.1007/s40033-022-00402-5>
- Dudlia, M., Pinka, J., Dudlia, K., Rastsvietaiev, V., and Sidorova, M. (2018), "Influence of dispersed systems on exploratory well drilling", *Solid State Phenomena*, no. 277, pp 44-53. <https://doi.org/10.4028/www.scientific.net/SSP.277.44>

About the authors

Antonchik Volodymyr, Chief Designer of the Department of Dynamic Machines for Mining Pressure Manifestations, M.S. Poliakov Institute of Geotechnical Mechanics of the National Academy of Sciences of Ukraine (IGTM of the NAS of Ukraine), Dnipro, Ukraine, Vladimir.antonchik1958@gmail.com, ORCID **0000-0002-4161-9112**

Hankevych Valentyn, Candidate of Technical Sciences (Ph.D.), Associate Professor, Senior Researcher in Department of Physics of Sorption Processes, Branch for Physics of Mining Processes of the M.S. Poliakov Institute of Geotechnical Mechanics of the National Academy of Sciences of Ukraine, Dnipro, Ukraine, ORCID **0000-0002-8535-6318**

Maltseva Vira, Leading Engineer of the Department of Management at Dynamic Manifestations of Rock Pressure, M.S. Poliakov Institute of Geotechnical Mechanics of the National Academy of Sciences of Ukraine (IGTM of the NAS of Ukraine), Dnipro, Ukraine.

Minieiev Serhii, Doctor of Technical Sciences (D.Sc.), Professor, Head of the Department of Management of Dynamic Manifestations of Rock Pressure, M.S. Poliakov Institute of Geotechnical Mechanics of the National Academy of Sciences of Ukraine (IGTM of the NAS of Ukraine), Dnipro, Ukraine, sergmineev@gmail.com, ORCID: **0000-0003-1056-3352**

Kiba Viacheslav, Senior Lecturer of the Department of Construction, Theoretical and Applied Mechanics, Dnipro University of Technology, Dnipro, Ukraine.

Livak Oksana, Candidate of Technical Sciences (Ph.D.), Associate Professor in Department of Materials Science, Ukrainian State University of Science and Technologies (USUST), Dnipro, Ukraine, Roxiki@i.ua, ORCID **0000-0002-5552-6531**

Velihina Nataliia, Candidate of Philology (Ph.D.), Associate Professor in Department of Foreign Languages, Dnipro University of Technology, Dnipro, Ukraine, nveligina@gmail.com.

УНІВЕРСАЛЬНИЙ ГІДРОПНЕВМОАМОТИЗАТОР БУРОВОГО СТАВУ

Антончик В., Ганкевич В., Мальцева В., Мінєєв С., Кіба В., Лівак О., Велігіна Н.

Анотація. У статті розглянуто питання захисту штанг бурового ставу і бурового обладнання від механічних коливань, які передаються від бурового долота при бурінні гірських порід. Осьові та тангенціальні коливання можуть перевищувати осьове зусилля подачі в 4 рази, а їх частота може бути в 3 рази вище частоти обертання бурового долота. Ці коливання можуть призводити до зношування обладнання, некоректного формування отворів, зниження безпеки робіт та зниження загальної продуктивності бурових робіт. Тому розуміння проблеми та застосування системи управління коливаннями є надзвичайно важливим для досягнення оптимальної продуктивності та забезпечення безпеки в бурових роботах.

Метою цієї статті є розробка амортизатора який зменшує зусилля як від осьових, так і тангенціальних коливань бурового ставу у процесі буріння гірських порід як шарошковими долотами, так і різцями.

Для досягнення поставленої мети виконано аналіз відомих засобів та механізмів для гасіння цих коливань як осьових, так і окружних (тангенціальних) викликаних як осьовим тиском бурового інструменту на вибій, так і обертальним моментом прикладеним до бурового інструменту. Визначено недоліки відомих пристроїв для гасіння осьових та окружних коливань. Розраховано час дії імпульсу вибою і час повного циклу коливань долота та амортизатора в результаті стискання і розтискання пружини. Визначено, що дія амортизатора підвищує тривалість дії імпульсу реакції вибою, плавно підвищуючи і зменшуючи силу від осьового зусилля. Розглянуто засоби гасіння механічних коливань в буровому обладнанні та показано шляхи їх перспективного розвитку. Розроблена конструкція універсального гідропневмоамортизатора для максимального гасіння як осьових, так і окружних коливань однаково придатного як для буріння шарошковими долотами, де переважає значне осьове навантаження так і ріжучими долотами, де поряд з осьовим навантаженням прикладено значний крутний момент. Описано переваги способу роботи цього гідропневмоамортизатора та його можливість працювати, використовуючи для гасіння коливань і видалення продуктів руйнування як стиснуте повітря, так і тиск рідини.

Ключові слова: гідропневмоамортизатор, буровий став, бурове долото, поздовжні та тангенціальні коливання, пружний елемент.