

SELECTION OF RUBBER COMPOUND TYPE FOR THE MANUFACTURE OF ELEMENTS OF A SELF-CLEANING GRATE-PANEL SCREEN FOR VIBRATING SIEVES

¹Pelykh I., ²Kononov D.

¹*M.S. Poliakov Institute of Geotechnical Mechanics of the National Academy of Sciences of Ukraine*

²*Ukrainian State University of Science and Technology*

Abstract. In laboratory conditions, domestic rubber compound was experimentally selected whose technical characteristics most closely correspond to the operating requirements of the elastic rubber components designed for a dynamically active self-cleaning grate-panel screen of a vibrating sieve. The technical development — a screening surface — can be applied for particle size classification of abrasive and cohesion-prone bulk materials, such as crushed stone, granite, slag, blast furnace coke, limestone, or wet sand with clay impurities. The intensification of the screening process on the self-cleaning grate-panel screen is achieved by complex spatial oscillatory displacements of the peripheral sections of the horizontal shelves of the elastic rubber grate-panel elements, which directly form the screen cloth. These elements are rigidly fixed into the grooves of longitudinal grate-like supports of the screening surface without preliminary deformation. The choice of the optimal type of rubber compound, as the raw material for subsequent manufacturing of rubber elements for the self-cleaning grate-panel screen, is based on determining and further analyzing the principal standard physico-mechanical parameters measured on full-scale samples of rubber products. In particular, during laboratory studies, the following technical indicators were identified and calculated: relaxation coefficient, residual elongation, dynamic modulus of elasticity, and energy absorption coefficient. As a result of the comprehensive laboratory investigations on groups of full-scale rubber product samples fabricated from parametric series of five domestic rubber compounds, compound 2959 was recommended for further application. This compound is suitable for vulcanization-based production of grate-panel rubber elements that directly form the screen cloth of the self-cleaning grate-panel screen of a vibrating sieve. When manufacturing rubber elements from compound 2959 by pressing, it is recommended to introduce a technological mode of vulcanization, thanks to which their Shore A hardness indicators would be achieved to the maximum possible values.

Keywords: rubber compound, vibrating sieve, blast furnace coke, self-cleaning grate-panel screen, Shore A hardness.

1. Introduction

At present, the process of fine and medium screening of abrasive materials with increased moisture content encounters significant difficulties due to clogging and blinding of the apertures of screening surfaces installed on vibrating sieves of various types and designs [1–6]. Such negative tendencies of reduced efficiency of fine (medium) screening processes, are particularly evident when processing moist and cohesion-prone bulk abrasive materials with a limiting particle size classified at 25 mm. An additional adverse influence on fine and medium screening processes is exerted by the presence of clay impurities in the feed material. Moreover, many researchers attribute the reduction in screening efficiency and the productivity of vibrating sieves in the separation of moist abrasive materials of a specified particle size to the excessive content of surface moisture [1, 6].

In particular, during the screening process, due to the interaction of fine moist particles of the classified abrasive material with each other, as well as their contact with the screening surfaces installed on modern vibrating sieves operating under metallurgical or mineral processing conditions, the following adverse phenomena are observed:

- poor loosening of the screened products, leading to reduced flowability;



- adhesion of fine and very fine particles to the surfaces of larger ones (formation of agglomerates composed of numerous adhered fine and very fine particles);
- gradual sticking of the vibrating sieve surface caused by the formation of a liquid film that retains fine and very fine particles of the moist classified material at the specified particle size.

Despite longstanding efforts, the challenges associated with screening moist, cohesion-prone abrasive materials remain unresolved. It is particularly well documented that the efficiency of screening processes on hearth-type vibrating sieves in blast furnace operations decreases sharply when classifying blast furnace coke with a moisture content exceeding 10% [8].

The above-mentioned issues can be partially mitigated by intensifying screening processes on vibrating sieves through the application of dynamically active screening surfaces, which may be manufactured entirely from metal or incorporating elastic materials.

As is well known, the application of elastomers in vibrating sieves in the form of rubber or polyurethane screens provides certain advantages [7–10]:

1. Reduced wear. Rubber is more resistant to abrasive wear during the screening of hard rocks compared to conventional steel, and it is particularly effective when handling angular or sharp-edged materials (such as crushed stone, granite, slag, or blast furnace coke).

2. Lower clogging tendency. Due to the elasticity of rubber, the apertures exhibit a “self-cleaning” effect—vibration induces oscillations of the aperture edges, causing trapped particles to be released. This is especially beneficial when processing moist or cohesion-prone bulk materials (e.g., limestone, wet sand with clay impurities, coal).

3. Noise reduction.

4. Extended service life. With proper selection of rubber hardness, the service life of screens may exceed that of steel analogues by a factor of 2–5.

There exists a wide variety of applications of rubber in sieves, particularly as screening surfaces. Notably, researchers at Ukrainian State University of Science and Technology and M.S. Poliakov Institute of Geotechnical Mechanics of the National Academy of Sciences of Ukraine developed and implemented a new design of a dynamically active screening surface for vibrating sieves—namely, the self-cleaning grate-panel screen (SCGS). This screen was specifically intended for high-quality separation of the constituent components of metallurgical charges by the specified particle size and provides the possibility of enhancing screening efficiency while ensuring high technical and economic performance of crushing and beneficiation equipment [11–14].

A fragment of the SCGS cloth is shown in Fig. 1.

The main distinguishing feature of the SCGS design is the absence of tensile and compressive stresses that arise in the curved sections of the actual working surface of the screen, which directly participate in the screening process, while simultaneously ensuring its high load-bearing capacity [11].

For the successful and long-term operation of the structural components forming the SCGS cloth, it is essential to select an appropriate rubber compound from which they will subsequently be manufactured. In particular, the production of SCGS rubber elements requires a raw material (rubber) that should meet the following requirements as closely as possible:

- long-term operability, cyclic durability, and minimal relaxation;
- resistance to puncture and cutting by sharp edges of moist abrasive material classified by the specified particle size;
- high modulus of elasticity to ensure sufficient load-bearing capacity;
- manufacturability of rubber-technical products using the pressing method.

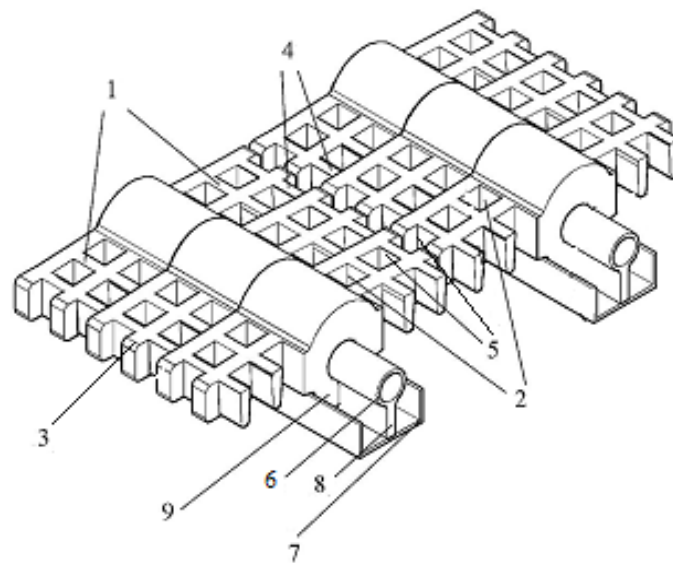

1 – internal ribs; 2 – closed-loop screening apertures; 3 – paired end protrusions-teeth;
4 – rectangular single-sided protrusions-teeth; 5 – open square screening apertures;
6–7 tubular and channel profiles; 8 – longitudinal support plate.

Figure. 1 – Fragment of SCGS cloth

The complexity in selecting the appropriate rubber grade for the production of SCGS lies not only in meeting the aforementioned performance criteria, but also in the requirement that, for mass production of such components, it is preferable to use rubbers based on general-purpose elastomers currently utilized in modern Ukrainian manufacturing.

2. Methods

The idea of the work is to conduct laboratory studies of rubber elements of the SCGS cloth and select a rational brand of domestic rubber mixture. The criterion for selection is compliance with the required mechanical characteristics of the rubber and the minimum value of the relaxation coefficient.

The aim of the laboratory experimental studies is to determine the actual technical characteristics of full-scale samples of rubber components that directly form the SCGS cloth of a vibrating sieve under both static and dynamic loading conditions. These components are manufactured from several types of domestic rubber

compounds, whose initial technical properties most closely correspond to the requirements of their operational conditions.

3. Results and discussion

Based on the experience of operating vibration equipment, which was previously developed and widely used in the mining and metallurgical industry, 5 brands of rubber compounds were selected.

The technical specifications of the investigated domestic rubber compounds are presented in Table 1.

Table 1– The technical specifications of the investigated domestic rubber compounds

Rubber Compound Grade	Type of Rubber in the Compound	Operating Temperature Range of Finished Products (°C)	Shore A Hardness (units)	Elongation at Break (%)	Tensile Strength (MPa)
IRP-1315	SKI-3; SKD	from -50 ⁰ to +80 ⁰	50 - 70	500	20
IRP-1370	SKI-3	from -50 ⁰ to +50 ⁰	60 -70	600	24,5
3826	Butadiene-Nitrile	from -30 ⁰ to +100 ⁰	60 - 75	300	7,8
6620	Isoprene	from -55 ⁰ to +80 ⁰	50 -60	500	15,7
2959	Natural	from -50 ⁰ to +80 ⁰	46 -61	500	15,7

The studies were carried out on groups of full-scale SCGS element samples fabricated from the five aforementioned rubber compounds, using a specially designed apparatus (laboratory test bench). This technical setup allows for the determination of the elastic–deformation characteristics of the tested full-scale rubber-technical samples under both static and dynamic loading conditions.

It should be noted that, on this test bench, the determination of the elastic–deformation characteristics of the tested full-scale samples was carried out without their destruction and without cutting fragments of specific shapes and sizes for testing. The developed laboratory test bench for conducting mechanical tests on groups of full-scale SCGS rubber component samples is shown in Fig. 2.

The laboratory test bench for mechanical testing of full-scale SCGS rubber element samples consists of a frame 1 with elastic sensing elements 4 and 5, identical to each other, mounted on it via prismatic supports 2 and 3. Elastic sensing element 4 interacts with the loading mechanism through the full-scale sample 6, which is realized as a movable traverse 7. The drive of the loading mechanism consists of a lead screw 8, nut 9, worm gear 10, worm 11, electric motor 12, and brake 13 with an electromagnetic drive 14. A group of strain gauges 15 is installed on elastic sensing element 4, while groups of strain gauges 16 and 17, also shunted with adjustable resistors, are mounted on elastic sensing element 5.

During dynamic tests, the tested full-scale rubber-technical samples were deformed in a local zone due to the periodic impact of a spring-loaded mass

(indenter). The design of the laboratory test bench allows the indenter to oscillate freely, with the time-dependent amplitudes of its rebound being recorded. The damping decrement of the rubber, as a function of the indenter's free oscillations and the amplitude of its vibrations generated by impacts on the tested material, was determined using the following formula [15]:

$$\delta(\omega) = \frac{\omega^2 \cdot \ln\left(\frac{\varphi_0}{\varphi_1}\right)}{\pi \cdot n(\omega^2 - \omega_\varphi^2)} - \frac{\delta_1(\omega_\varphi)\omega^2}{\omega^2 - \omega_\varphi^2} - \frac{\delta_1(\omega_\varphi)\omega^2}{\omega^2},$$

where φ_0, φ_1 – are the amplitude of the free oscillations of the mass and the rebound amplitude, respectively, rad;

ω, ω_φ – are the frequency of the mass's free oscillations and the frequency of its free oscillations upon impact with the tested material, 1/s;

$$\omega = \frac{\pi}{t_0},$$

where t_0, t_1 – rebound time of the mass and its contact time; $\delta_1(\omega_\varphi)$, – damping decrement of the spring at the corresponding frequencies; n – number of oscillation cycles of the masses.

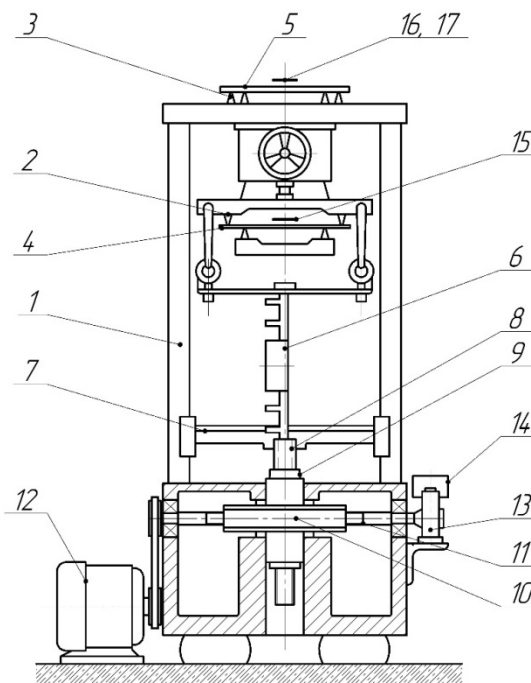

1 – frame; 2, 3 – rismatic supports; 4, 5 – elastic sensing elements; 6 – rubber sample of a grate-card element; 7 – movable traverse; 8 – lead screw; 9 – nut; 10 – worm gear; 11 – worm; 12 – electric motor; 13 – brake; 14 – electromagnetic drive; 15 – 16 – 17 groups of strain gauges

Figure 2 – Laboratory test bench for mechanical testing of full-scale SCGS rubber element samples

The dynamic modulus of elasticity of the rubber full-scale samples (E) was determined according to [15] as a function of the indenter's rebound time and penetration time:

$$E(\omega_\varphi) = k \cdot m(\omega^2 - \omega_\varphi^2),$$

where k – coefficient accounting for the indenter shape; m – equivalent mass of the spring-loaded load.

In addition, based on the obtained experimental data, hysteresis loops were recorded, and the energy dissipation (absorption) coefficient (f) was determined. These laboratory studies were conducted at an ambient temperature of $T = 25 \pm 2^\circ\text{C}$. Furthermore, thanks to the above-mentioned laboratory equipment, it is possible to record the relaxation curve under static loading of the tested rubber products over a prolonged period and to determine the dynamic characteristics of the rubber of these full-scale samples.

The results of bench tests for groups of full-scale samples fabricated from the five aforementioned domestic rubber compound grades are presented in Table 2.

Table 2 – The results of bench tests

Rubber Compound Grade	Number of Full-Scale Rubber Product Samples	Static Characteristics of the Samples		Dynamic characteristics of samples			
		Relaxation Coefficient	Residual Elongation (%) at a Load of $P = 250$ N	Residual Elongation (mm) under Tests at $w = 16$ Hz, $N = 10^5$ Cycles	Natural Frequency of Oscillations (1/s)	Dynamic Modulus of Elasticity E ($\text{N/m}^2 \times 10^5$)	Energy Dissipation Coefficient f
IRP-1315	8	0.94	9	16–20	51.3–55.6	85.2–3.1	0.31–0.33
IRP-1370	8	0.85	10	18–21	54.1–58.2	93.4–103	0.51–0.53
3826	6	0.56	11	16	54.2	101.4	0.5
6620	6	0.68	13–16	17–19	37–38.5	40.1–41.9	0.39–0.42
2959	8	-	5	13–15	48.2	65–67	0.36

According to the results of laboratory studies of the rubber products presented in Table 2, the relaxation coefficient represents the ratio of the tensile forces in the shelves of the SCGS element in the equilibrium state to the initial loading force. The dynamic modulus of elasticity (E) and the energy dissipation coefficient (f) of the tested rubber samples were determined using the above formulas and the developed laboratory test bench. Thus, complete experimental and calculated data were obtained to determine the actual mechanical characteristics of the five types of elastic materials from which the full-scale rubber element samples forming the SCGS cloth were fabricated.

As a result of static loading and repeated cyclic deformation, all tested full-scale SCGS samples exhibited relaxation of their horizontal shelves, which form the openings of the screen cloth. The relaxation effect over time manifested as gradual

deformation—elongation of the horizontal shelves of the tested samples by 3–14% of their initial length. This leads to the disruption of the contour integrity of the open openings in the SCGS cloth and, ultimately, is one of the causes of its loss of operational performance.

The results of laboratory studies of the full-scale rubber samples presented in Table 2, both under static and dynamic tests, demonstrate the superiority of the group of samples fabricated from rubber compound 2959 over the other tested groups.

The group of tested samples made from rubber compound 2959 exhibits a minimal relaxation coefficient of 3%, which is determined as the ratio of the tensile forces in the horizontal shelves of the SCGS element in the equilibrium state to the initial loading force. In addition, the values of the energy dissipation coefficient (f) and the dynamic modulus of elasticity (E) are within ranges that ensure both minimal heat generation and sufficient cyclic durability.

However, according to the technical specifications, the full-scale samples made from rubber compound 2959 exhibit the lowest Shore A hardness values, ranging from 46 to 61 units. Over time, under the influence of impact loads generated during the classification of wet abrasive materials on a vibrating screen, this inevitably leads to their gradual physical wear, subsequent destruction, and, consequently, the inability to ensure efficient operation of the vibrating screen.

4. Conclusions

Notably, researchers at Ukrainian State University of Science and Technology and M.S. Poliakov Institute of Geotechnical Mechanics of the National Academy of Sciences of Ukraine developed and implemented a new design of a dynamically active screening surface for vibrating sieves—namely, the self-cleaning grate-panel screen (SCGS). This screen was specifically intended for high-quality separation of the constituent components of metallurgical charges by the specified particle size and provides the possibility of enhancing screening efficiency while ensuring high technical and economic performance of crushing and beneficiation equipment

It has been established that one of the most important factors influencing the durability (operating capacity) of the surface of the SCGS of a vibrating screen is the relaxation characteristics.

Laboratory studies of full-scale grate-panel samples directly forming the SCGS, fabricated from five domestic rubber compound grades, allowed the identification of the optimal compound that best meets the requirements of minimal relaxation and high load-bearing capacity.

Based on the conducted tests, for the fabrication of the SCGS cloth and its subsequent industrial testing, rubber compound 2959 is currently recommended, as its elastic–deformation characteristics are the most capable of meeting the actual operational conditions.

During the pressing fabrication of SCGS rubber elements from rubber compound 2959, it is recommended to implement a vulcanization regime that ensures the Shore A hardness of the elements reaches the maximum achievable value of 61 units.

Conflict of interest

Authors state no conflict of interest.

REFERENCES

1. Zaselsky, V.Y. Popolov D.V., Zaitsev G.L., Bilodidenko S.V., Kononov D.O. and Pelykh I.V. (2019), *Udoskonalennya obladnannya ta protsesiv vuhlepidhotovky i koksosortuvannya metalurhiynoho vyrobnytstva* [Improving the equipment and processes of coal preparation and coking plant sorting of metallurgical production], R.A. Kozlov, Kryvyi Rih, Ukraine.
2. Usachov, V.P. (1994), *Tekhnolohichni liniyi ta komplekсы tsekhiv. Chastyna 2. Tekhnolohichni osnovy komponuvannya liniy u metalurhiynomu vyrobnytstvi*. [Technological lines and complexes of workshops. Part 2. Technological foundations of the layout of lines in metallurgical production], ISDO, Kyiv, Ukraine.
3. Smyrnov, V.O. and Biletsky, V.S. (2012), *Pidhotovchi protsesy zbahachennya korysnykh kopalyn* [Preparatory processes of mineral processing], Eastern Publishing House, Donetsk branch of the Shevchenko Scientific Society, Donetsk, Ukraine.
4. Boiko, V.S. (2012), *Tekhnolohiya ta obladnannya dlya zbahachennya korysnykh kopalyn* [Technology and equipment for mineral processing], Condor Publishing, Kyiv, Ukraine.
5. Vasyliiev, V.M. (2016), *Teoriya ta praktyka prosiyuvannya sypuchykh materialiv* [Theory and practice of screening bulk materials], O.M. Beketov National University of Urban Economy in Kharkiv, Kharkiv, Ukraine.
6. Linhares, T.B., Scari, A.S. and Vimieiro, C.B.S. (2024), "Causes of failures in vibrating screens: A literature review", *Minerals Engineering*, vol. 218, 109027. <https://doi.org/10.1016/j.mineng.2024.109027>
7. Bulat A.F., Dyrda V.I., Zviagyl'skyi E.D., Nadutyi V.P., Loginova A.P., Puhalsky V.N., Lysitsa V.I. and Morus, V.L. (2016), *Elastomery v gornom dele* [Elastomers in mining], Naukova dumka, Kyiv, Ukraine.
8. Bulat, A.F., Dyrda, V.I., Pukhalsky, V.N. and Lysytsia, M.I. (2018), "Development and creation of vibrating equipment using elastomers for the extraction, processing and beneficiation of mineral raw materials", *Geotechnical Mechanics*, vol. 138, pp. 273–282.
9. Bulat, A.F., Dyrda, V.I. and Pukhalsky, V.N. (2013), "Machines and technologies for underground mining of uranium-containing ores based on elastomer structures", *Geotechnical Mechanics*, vol. 113, pp. 44–53.
10. Lin, D., Ji, J., Yu, Ch., Wang, X. and Xu, N. (2023), "A non-linear model of screen panel for dynamics analysis of a flip-flow vibrating screen", *Powder Technology*, vol. 418, 118312, <https://doi.org/10.1016/j.powtec.2023.118312>
11. Pelykh I. V., Uchitel O. D., Onatskyi S. M., Petrenko V. O., Bergeman G. V., Shybo O. V. and Ivashchenko V. P., National Metallurgical Academy of Ukraine (2010), *Kolosnikovo sito* [Colander sieve], State Register of Patents of Ukraine, Kiev, UA, Pat. No. 90387.
12. Pelykh, I.V., Belodedenko, S.V., Kononov, D.O. and Petrenko, V. A. (2009), "Rational design of the surface of a vibrating screen for metallurgical production", *Metallurgical and Mining Industry*, vol. 4, pp. 79–82.
13. Belodedenko, S.V., Kononov, D.O. and Pelykh, I.V. (2013), "Research of the coke screening process on a model of a vibrating screen", *Metallurgical and Mining Industry*, vol. 4, pp. 97–100.
14. Kononov, D.O., Yermokratiev, V.O. and Pelykh, I.V. (2024), "Development of methods for predicting the technological performance of a vibrating screen with elastic screens", *System Technologies. Regional inter-university collection of scientific papers*, vol. 2(151), pp.156–165. <https://doi.org/10.34185/1562-9945-3-152-2024-16>
15. Poturaev, V.N., Chervonenko, A.G., Krush, I.I. and Lysytsia, M.I. (1983), "Methods for determining the mechanical characteristics of elastic materials", *Voprosy mekhaniki rezinovykh konstruksii tyazhelykh gorno-metallurgicheskikh mashin: tezisy dokladov simpoziuma* [Issues of mechanics of rubber structures of heavy mining and metallurgical machines: abstracts of symposium reports], IGTM NANU, Dnipro, Ukraine, pp. 21-22.

About the authors

Pelykh Ihor, Candidate of Technical Sciences, Scientific Researcher of Department of Mechanics of Mineral Processing Machines and Processes, M.S. Poliakov Institute of Geotechnical Mechanics of the National Academy of Sciences of Ukraine (IGTM of the NAS of Ukraine), Dnipro, Ukraine, razmah.ivp@gmail.com ORCID [0009-0002-9899-7875](https://orcid.org/0009-0002-9899-7875)

Kononov Dmytro, Candidate of Technical Sciences, Associate Professor of the Industrial Engineering Department, Dnipro Metallurgical Institute, Ukrainian State University of Science and Technology, Dnipro, Ukraine, d.o.kononov@ust.edu.ua (**Corresponding author**), ORCID [0000-0001-9505-5298](https://orcid.org/0000-0001-9505-5298)

ВИБІР ТИПУ ГУМОВОЇ СУМІШІ ДЛЯ ВИГОТОВЛЕННЯ ЕЛЕМЕНТІВ САМООЧИСНОГО КОЛОСНИКОВО-КАРТКОВОГО СИТА ВІБРАЦІЙНОГО ГРОХОТА

Кононов Д., Пеліх І.

Анотація. В лабораторних умовах, шляхом експериментальних досліджень вибиралася вітчизняна гумова суміш, технічні характеристики якої найбільше відповідають умовам експлуатації виготовлених з неї складових пружних гумових елементів розробленого динамічно активного самоочисного колосниково-карткового сита вібраційного грохота. Вищевказана технічна розробка - поверхня що просіває, може бути використана для класифікації по заданій крупності абразивних та схильних до злипання сипких вологих матеріалів, наприклад щебню, граніту, шлаку, коксу доменного, вапняку або вологого піску з глинистими домішками. Інтенсифікація процесу грохочення

на ситі самоочисному колосниково-картковому забезпечується можливість здійснення складних просторово-коливальних переміщень периферійними ділянками горизонтальних полиць пружних гумових колосниково-карткових елементів, безпосередньо формуючих ситове полотно, які без попередньої деформації жорстко встановлюються в пази повздовжніх колосникоподібних опор даної поверхні що просіває. Вибір оптимального типу гумової суміші, як вихідного матеріалу, призначеному для подальшого виготовлення із нього гумових елементів самоочисного колосниково-карткового сита, ґрунтується на визначенні і подальшому аналізу основних стандартних фізико-механічних показників, визначених в виготовлених натурних зразках гумових виробів. Зокрема, в процесі проведення лабораторних досліджень визначались і розраховувались такі технічні показники, як коефіцієнт релаксації, залишкове подовження, динамічний модуль пружності, коефіцієнт поглинання енергії. Завдяки проведеному комплексу лабораторних досліджень груп натурних зразків готових гумових виробів, виготовлених з параметричного ряду гумових сумішей, який складався з п'яти видів вітчизняних гумових сумішей, для подальшого використання рекомендована гумова суміш 2959, яка надалі може слугувати для виготовлення з неї методом вулканізації складових колосниково-карткових гумових елементів, безпосередньо формуючих ситове полотно самоочисного колосниково-карткового сита вібраційного грохота. При виготовленні методом пресування гумових елементів з суміші 2959 рекомендовано запровадити такий технологічний режим вулканізації, завдяки якому показники їхньої твердості по Шору А досягалися б до максимально можливих значень.

Ключові слова: гумова суміш, вібраційний грохот, кокс доменний, сито самоочисне колосниково-карткове, твердість по Шору А.