

## Simulation of nonstationary regimes of gas transmission systems operation

Prytula N. M.<sup>1,2</sup>, Gryniv O. D.<sup>2</sup>, Dmytruk V. A.<sup>1,3</sup>

<sup>1</sup>*Centre of Mathematical Modelling of Ukrainian National Academy of Sciences*

*15 Dudayev str., 79005, Lviv, Ukraine*

<sup>2</sup>*LTD “Mathematical centre”*

*48 Volodymyr the Great str., 79054, Lviv, Ukraine*

<sup>3</sup>*Lviv Polytechnic National University*

*12 S. Bandera str., 79013, Lviv, Ukraine*

(Received 2 December 2014)

A mathematical model of the gas transmission system is studied in this article. Models of gas flows in the main technological objects that are involved in the transportation of gas are represented. The structure of the system is represented in terms of graph theory. Adaptive algorithm of the gas transportation system model implementation is constructed and real-world examples of its work are presented in this paper.

**Keywords:** *gas transmission system, technological scheme, model of gas flow, system operation mode*

**2000 MSC:** 35B; 65P

**UDC:** 621.64.029

### 1. Introduction

A mathematical model of the gas transmission system is based on its technological scheme. Structural properties of the technological scheme affect both the dimension of the system of equations (i.e. the system model) and the complexity of its solution. Technological scheme brings together a large number of objects and their technological schemes together. All technological objects can be divided into two classes. The first class features objects that do not have a mathematical model of the gas flow. They are called information or calculation ones. The calculation objects feature, at first, objects with a gas flow which is characterized by component composition, density, flow rate, pressure, and temperature. The main objects with gas flow model include: a main pipe, stop and control valves according to pressure and flow rate, a gas-pumping unit (GPU), a compressor plant, a multiunit compressor station, air-coolers of gas, gas cleaning and drying systems. The objects mentioned above possess the concept “the beginning” and “the end”, or inlet and outlet. The object model allows us to connect the gas flow parameters at its inputs and outputs.

A mathematical model of the gas transmission system has been formed on the base of: a mathematical model of the structure of GTS, models of gas flows in technological objects, coupling flow conditions based on balance relations, forecast data (temperature of environment), changes in the state of objects, the inflow into the system and withdrawing from the system.

A mathematical model of the structure of GTS is partially oriented graph without loops, not necessarily connected one  $G = (V, E)$ , which consists of a finite number of vertices  $V$  and edges  $E$ . The set  $V$  is the union of the sets of vertices  $V_1, V_2, V_3$  called input, output, and internal ones, respectively. The internal vertices are points of the junction of pipelines and other facilities. Vertices  $V_1$  and  $V_2$  accordingly are sources (inflow) and withdrawing of gas. Objects characterized by a length are called edges (arcs) (pipelines, GPU, CS, stop and control valves, air-coolers, separators, etc.).

Structural properties of technological scheme affect both the dimension of the system of equations (the system model) and its solution stability. The carried out numerical experiments have shown that

some transformations of the technological scheme into a schematic graph provide greater stability of the method and reduce the time of solving proper systems of equations. The basic operations on these graphs are the uniting of edges and subgraphs and their identification with some edges and vertices. Of great importance is the sequence of operations. Significant restrictions on the operations and their sequence impose boundary conditions existing in operational tasks. The process of solving problems requires the maximum automation of the process of forming a system model. It, in its turn, requires the construction of appropriate algorithms that would provide full automation of modification of the initial technological schemes and the formation of the corresponding systems of equations.

We assume that each object of the type “vertex” or “edge” in the GTS have unique numbers that are not changed during the transformation of the graph  $G$ . The initial schematic graph  $G$  is unique. If there is another schematic graph of GTS operation, it is isomorphic because obtained from  $G$  using operations of compression. Such operations are needed, first and foremost, to reduce the dimensionality of the systems of equations describing gas-dynamic processes in GTS and to ensure better convergence of the method of their solving.

Consider both objects: individual ones and that are connected according to the technological scheme (system objects). Objects are characterized by the notion of their state. Each object state is characterized by a set of parameters that affect the nature of the gas flows in this object and in the system as a whole. The change of the state of GTS objects occurs under the established regulations of both: objects and systems. Regulations are formed by dispatching services, taking into account the planned activities, as well as under the correction or changing the mode of the system.

A mode of GTS operation is formed on the basis of the initial state  $S_0$  and the forecast over the time interval  $[0, t]$ : works that change the technological scheme  $G(V, E)$  and its parameters; flow parameters at the inlets  $r^+ = \{P^+, T^+, Q^+, \rho\}$  and the outlets  $r^- = \{P^-, T^-, Q^-, \rho\}$  (in the braces there are the pressure, the temperature, the flow rate and the density of gas, respectively); parameters of the environment. The calculation mode  $R_r$ , in addition to mentioned parameters, still depends on calculation methods, algorithms  $A$ , the mode quality criteria, and the principle of optimal control of gas flows  $F$ . We assume that the regime, technical, technological, and thermo-fuel-energy constraints are given.

The GTS mode is determined by the function of pressure and temperature in all vertices of the GTS graph, by the density and flow rate at all edges. Since the measurement of these parameters is carried out for a limited number of vertices, most parameters are necessary to be determined.

## 2. Models of gas flows in the major technological objects

### 2.1. The model of the pipeline

In order to develop a model of the system under the study, to develop a method and algorithm of its operational parameters calculation, consider a part of the main gas pipeline, which consists of a compressor station with adjoining pipelines. We assume that at the initial time, the mode of the gas flow is steady. Unsteady gas flow in the pipeline is described by interconnected differential equations in partial derivatives in the form [1]

$$\begin{aligned} \frac{\partial(\rho v)}{\partial t} + \frac{\partial p}{\partial x} + \frac{\partial \rho v^2}{\partial x} + \frac{\lambda \rho v^2}{2D} + \rho \frac{\partial h}{\partial x} &= 0 \\ \frac{\partial(\rho v)}{\partial x} + \frac{\partial p}{\partial t} &= 0 \\ \frac{\partial}{\partial t} \left[ \rho \left( e + \frac{v^2}{2} \right) \right] + \frac{\partial}{\partial x} \left[ \rho v \left( e + \frac{v^2}{2} \right) \right] &= \frac{\Omega}{F} - \rho v \frac{\partial h}{\partial x} \\ p &= \rho z RT \end{aligned} \tag{1}$$

where  $v$  is velocity of the gas in the pipeline,  $\rho$  is the density gas,  $D$  is the inner diameter of the pipeline,  $h$  is the relative height of the pipeline position,  $\lambda$  is the coefficient of hydraulic resistance,  $\Omega$  is heat

flux exchange with the environment,  $F$  is the cross-sectional area,  $e$  is internal energy,  $R$  is the gas constant,  $T$  is the gas temperature,  $t > 0$  is time;  $x \in [0, l]$  is the linear coordinate,  $l$  is the length of the pipeline.

To calculate the compression ratio  $z$ , it can be used empirical formula [2]

$$z = (1 + fp)^{-1} \quad (2)$$

where  $p$  is measured in atmospheres,  $f = (24 - 0.21t^\circ C) \cdot 10^{-4}$ ,  $t^\circ C$  is Celsius temperature of gas, which describes the difference between a real gas from ideal one with sufficient accuracy for practice.

The most important parameters of unsteady regime is the pressure  $p$  and the flow rate  $q$ , which are included in first two equations (conservation of momentum and continuity of flow). The third equation is the energy conservation which is based on the processes of heat transfer. The rate of change of temperature in time is considerably less than the rate of change of pressure and flow rate of gas. So, in the third equation the time derivatives are neglected, which sufficiently simplifies the solving systems of equations. Therefore in the third equation the time derivatives are neglected, what sufficiently simplifies the solving of the system of equations. Since the changes of gas parameters over significant time intervals are relatively slight, the calculation of temperature distribution along the pipeline section we carry out according to the formula for steady gas flow. Along the length of the pipe it varies under the law

$$T = T_{gr} + (T_0 - T_{gr}) e^{-ax} - \left[ D_i \frac{p_n - p_k}{L} + \frac{q\Delta h}{C_p L} \right] \frac{1 - e^{-ax}}{a}, \quad (3)$$

where denoted:  $T_0$  is the gas temperature at the pipe inlet;  $T_{gr}$  is the temperature of soil;  $D$  is the Joule-Lents's coefficient;  $C_p$  is the coefficient of heat transfer from gas to soil;  $\Delta h$  is the level difference between the ends of the pipeline;  $p_0, p_k$  are the values of pressure at the inlet and at the outlet of the pipeline;  $k$  is the coefficient of heat transfer from the pipe to soil;  $a = \frac{k\pi D}{C_p M}$ .

**Example 1.** Figure 2 shows the results of the calculation of non-stationary mode of the pipeline. The error of the simulation is the largest at initial period of time. Throughout the interval of simulation, the calculation error is within the accuracy of measurement of pressure.

**Example 2.** We consider a GTS section with the given amounts of withdrawn gas, placed along its length.

Imposing for Southern Bug CS (to the left of the pipeline) a boundary condition on pressure at the outlet, and the boundary condition on the flow rate of gas at all other facilities of gas withdrawing for a period of 3 days, we obtain the following results of simulation of gas-dynamic processes of this subsystem (simulation had been carried out for 70 hours, step was with respect to the time-variable  $\Delta t = 600$  c):

Now, for this system we impose the boundary condition on gas pressure in Ananyiv and obtain the following results:

## 2.2. Model of CS gas flow. Model of compressor station

A model of compressor station (CS) is formed on the basis of the model of the structure and models of its technological objects. The structural model is represented as a graph in which the objects characterised by the length are represented by the edges and all others by the vertices. The main object – pumping unit – is represented by the drive and centrifugal compressor (CC). It is known [3] that the parameters of the gas at the inlet and at the outlet of CC are connected by the set of empirical relationships

$$\varepsilon = \varphi_1 \left( [q]_{np}, \left[ \frac{n}{n_H} \right]_{np} \right), \quad \eta_{pol} = \varphi_2 \left( [q]_{np} \right), \quad \frac{N_i}{\gamma_n} \left( \frac{n_n}{n} \right)^3 = \varphi_3 \left( [q]_{np} \right).$$

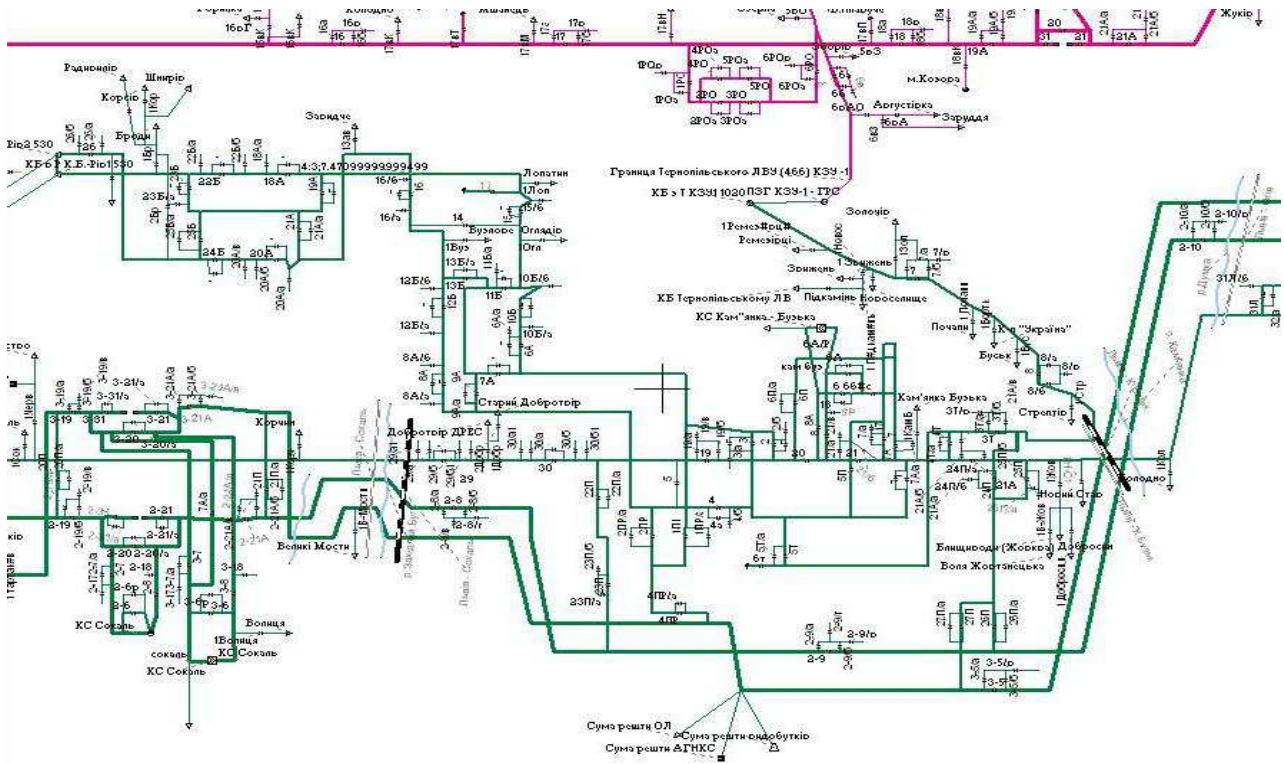
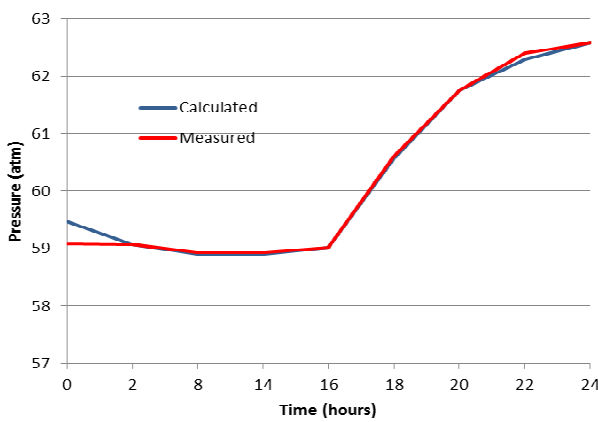


Fig. 1. Pcess technological scheme fragment.



Time (hours.)	Calculation	Input data	Error
0	59.47	59.09	0.38
2	59.07	59.07	0.00
8	58.90	58.93	0.02
14	58.90	58.94	0.04
16	59.02	59.01	0.01
18	60.57	60.60	0.03
20	61.76	61.75	0.01
22	62.29	62.40	0.11
24	62.58	62.59	0.01

Fig. 2. The calculated and measured values of pressure at the valve 60 (1673 km) of the “Soyuz” pipeline.

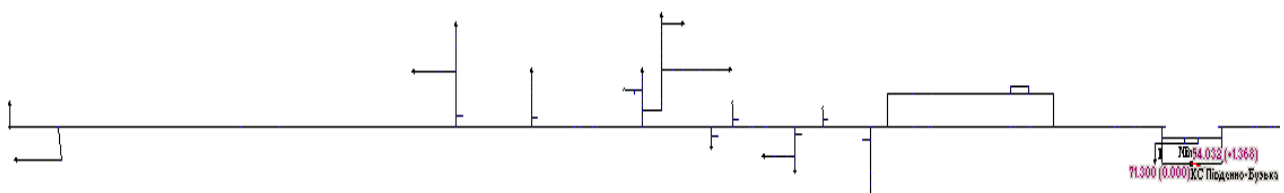
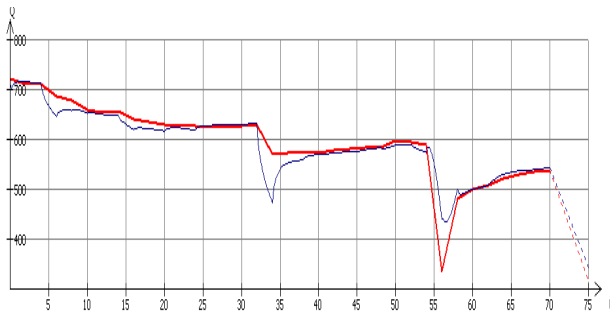
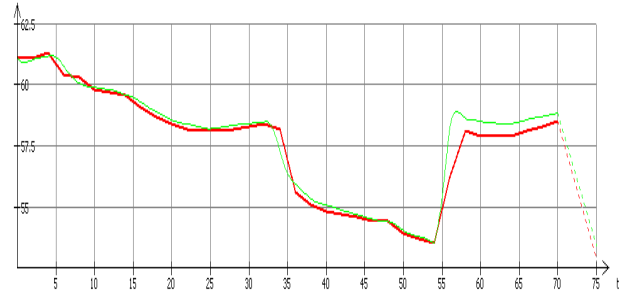


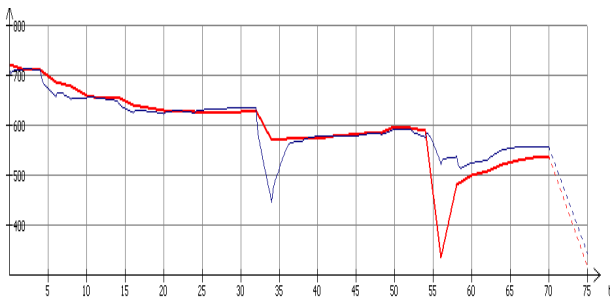
Fig. 3. Layout of the GTS section “Southern Bug CS – Ananyiv” (Odessa region).



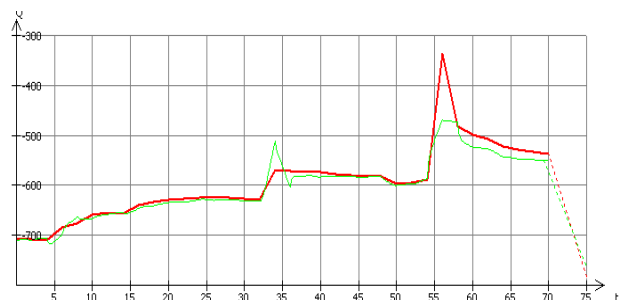
**Fig. 4.** Graphs of changes of the volume flow rate at the Southern Bug CS (red is measured, blue is calculated).



**Fig. 5.** Graphs of changes in gas pressure in Ananyiv (red is measured, green is calculated).



**Fig. 6.** Graphs of changes of the volume flow rate at the Southern Bug CS (red is measured, blue is calculated).



**Fig. 7.** Graphs of changes of the volume flow rate in Ananyiv (red is measured, green is calculated).

$$T_{28E}z_{28E} = T_{2E}z_{2E}\varepsilon^{\frac{k-1}{k\eta_{pol}}}, \quad N_e^P = N_e^- K_{Ne} \left( 1 - K_t \frac{t_0 - t_0^n}{t_0 + 273} \right) \frac{p_a}{0.1033},$$

Other operating parameters of GPA we find by the formulae:

$$q_{pg} = q_{pg}^n K_t \left( 0.75 \frac{N_e}{N_e^n} + 0,25 \sqrt{\frac{t_0 + 273}{t_0^n + 273} \frac{p_a}{0.1033}} \right), \quad q_{pg}^n = \frac{860 N_e^n}{\eta_e^n Q_n 10^3}, \quad N_e = N_i : (\eta_m K_N).$$

where  $n$  is a number of turnovers of CC,  $q$  is the flow rate at CC,  $\eta_{pol}$  is polytrophic efficiency of CC,  $q_{pg}^n$  is the nominal consumption of fuel gas,  $\varepsilon$  is the compression ratio,  $N_e^n$  is the nominal power of gas turbine;  $K_{Ne}$  is the coefficient of technical state of gas turbine;  $K_t$  is the coefficient for the effect of air temperature;  $t_0$  is the air temperature at the inlet of gas turbine;  $t_0^n$  is the nominal temperature at the inlet of gas turbine;  $p_a$  is the absolute pressure of air depending on the altitude  $H$ ;  $t_0$  is the air temperature ( $^{\circ}C$ ) at the inlet of gas turbine,  $Q_n$  is the nominal lower specific volume heat combustion of fuel,  $\eta_e^n$  is nominal efficiency of gas turbine,  $\eta_m$  is mechanical efficiency,  $K_N$  is the technical condition according to power.

There is a set of technological restrictions for: the position of working points on the characteristics of CC for providing the operation of GPU without pumping; maximum volumetric productivity of CC; rotational speed of the turbine of CC ( $n_{min} \leq n \leq n_{max}$ ); maximum power of gas turbine of GPU; maximum output pressure of CC, which is defined by the durability of pipelines at the outlet of CC; maximum temperature at the outlet of CC, which is defined by an insulating coating of pipelines; minimum pressure at the outlet of each CC; conditions associated with a certain degree of stability of the GPU (distance from the zone of pumping); terms of coherence of the circuit CC connection with inlet and outlet of trails and gas mains.

Calculation algorithm of CS for a set of input data  $(\rho_c, P_1, P_2, T_1, q, \{M_i^k\})$  (the density of gas under standard conditions, the gas pressure at the inlet and the output gas pressure, gas flow rate, a set of GPU in each  $i$ th shop) calculates the CS operation mode (outlet temperature, the technological scheme of GPU:  $i$  is the number of level,  $j$  is the number of GPU of the level,  $k$  is the type of GPU; turnovers of CC, compression ratio, the amount of fuel gas for operation of gas turbine and gas turbine power). Indices  $(i, j) \in \{N_i^k, N_j^k\}$  ( $N_i^k$  is a set of levels of CS operation,  $N_j^k$  is a set of GPU at the  $j$ th level).

**Example 3 (Calculation of the operation mode for the 5-shop CS).** In Table 1, the 1st column contains the values of volumes of gas compression, the 2nd column – estimates of the volumes of fuel gas consumption for operation mode.

**Table 1.** Modes of CS operation for different values of pressure at its inlets and outlets.

Q1(mln.m3)	Q1p(mln.m3)	Regimes
102.2	0.14	[1]1:II-6,3/41[6318], [2]9,10,12:III-16/56[4124]
106.8	0.18	[1]1:II-6,3/41[6108], [2]9,10,12:III-16/56[4395]
107.1	0.47	[2]9,10:III-16/56[4860],11:III-16/41[5030] – [2]12,13:III-16/56[4484], [4]24,25:II-6,3B/29[6325] – [4]27,28:II-6,3B/41[6254]
100.8	0.47	[2]9,10:III-16/56[4692],11:III-16/41[4872] – [2]12,13:III-16/56[4562],14:III-16/76[4564], [4]24,25:II-6,3B/29[6086] – [4]27, 28:II-6,3B/41[6511]
106.3	0.52	[1a]22:II-16/29-1.6[5506],23:III-16/41[3985] – [2]9,10,12:III-16/56[4279] – [3]15,16,17,18,19:III-16/100[4506]

**The structure of the mode tape** [2]9,10:III-16/56[4692],11:III-16/41[4872] – [2]12,13:III-16/56[4562],14:III-16/76[4564], [4]24,25:II-6,3B/29[6086] – [4]27,28:II-6,3B/41[6511] **is the following** [ $N^{\circ}$  of shop] $N^{\circ}$  GPU1,  $N^{\circ}$ GPU2[turnovers] – [ $N^{\circ}$  of shop] $N^{\circ}$ GPU1,  $N^{\circ}$ GPU2[turnovers], [ $N^{\circ}$  of shop] $N^{\circ}$  GPU1,  $N^{\circ}$ GPU2[turnovers] – [ $N^{\circ}$  of shop] $N^{\circ}$  GPU1,  $N^{\circ}$ GPU2[turnovers], where “–” disunites levels, and “;” means that levels work in parallel.

### 2.3. Model of gas flows in GTS

For all vertices of the schematic graph, whose power is equal or greater than two, the following conditions are to be fulfilled:

a) mass flow balance

$$\sum_i m_{ij}(t) + \sum_k m_{jk}(t) = 0, \quad j \in V. \quad (4)$$

b) heat balance

$$T_J(t) \sum_k q_{jk}(t) - \sum_i q_{ij}(t)T_i(t) = 0, \quad j \in V. \quad (5)$$

c) the equation of gas mixture state

$$P \sum_k V_k = \sum_i x_i(PV)_i + \sum_j \sum_k x_j x_k F_{jk}(T, \rho), \quad PV = Rf(T, \rho), \quad (6)$$

where  $q_{ij}$  is the volume gas flow rate at the section  $(i, j)$  in the vicinity of the vertex  $j$ ,  $T$  is the gas temperature,  $V$  is the gas volume,  $P$  is the gas pressure,  $R$  is the gas constant,  $x_i$  is the mole fraction of gas components,  $F_{ik}$  is the gas components interaction function, which are determined experimentally.

The system of equations (1)–(6) is supplemented with initial and boundary conditions. It has a unique solution if the power of gas compressing were additionally given for all operating CS, which would allow us to estimate the relative frequency of rotation of the shafts of centrifugal compressors (CC) of each GPU, gas flow rate, inlet pressure, and outlet pressure, the pressure drop at CS, fuel gas consumption, and electricity costs.

### 3. Adaptive method for calculating unsteady regimes

Iterative procedure for solving this problem of mathematical physics is implemented using the finite element method (FEM). The algorithms of calculation of non-stationary processes in GTS providing adaptation to the set task, the parameters of technological schemes (PF), the behavior of gas-dynamic processes are developed. PF modification involves taking into account parameters of PF objects and method parameters. Among them we distinguish:

- **The length of objects.** If we neglect the length of open valves, identify the appropriate edge with the vertex, and connect sections of pipelines of the same diameter, the PF will be much simplified and as a result we will get a much smaller number of edges, and hence a smaller number of the equations in the model. Sections of pipelines of the length  $L$  under condition ( $L < \varepsilon_L$ ) can be also identified with the vertices.
- **A number of dividers of pipeline sections (edges) of the FEM.** The number of equations in the system depends on the number of points of edges partitioning, and thus the speed and stability of this system solving. The choice of the partitioning number in the FEM must ensure both the stability and the accuracy of solving systems of equations.
- **Time step.** For processes close to stationary it is advisable to choose the maximum time step and in the case of rapidly changeable gas-dynamic processes, it needs to be significantly portioned. This technique has been always used when the state of valves alters.
- **The number of iterations.** To achieve a given accuracy of results, intermediate results must not always be of the same accuracy.
- **Valve opening with a gradual alignment of pressures at its inlets and outlets.** During the calculation of complex systems and in the case of significant pressure drops at the valve ends, it is expedient to align pressures “smoothly” by choosing the value of time steps so as to ensure the stability and accuracy of solving the corresponding systems of equations.

Consider the ideas implemented in the algorithm of calculation scheme simplification represented as a graph. It is obvious that the current graph should not contain edges of the zero length or diameter, so these edges are identified with the vertex (open valves, bypass valves, control valves). It is also expedient to consider the sequence of edges that have the same diameter as the one edge. That is, if arbitrary adjacent edges  $e_j = (v_{i-1}, v_i)$ ,  $e_{j+1} = (v_i, v_{i+1})$  have the same diameter  $|D_{e_j} - D_{e_{j+1}}| < \varepsilon_D$ , where  $\varepsilon_D$  is the diameter values tolerance, they can be replaced by one edge  $e_j^* = (v_{i-1}, v_{i+1})$ , removing from the graph the vertex  $v_i$ , edges  $e_j$  and  $e_{j+1}$  and assigning the value of the new edge length to be equal to the sum of the two jointed edges  $L_{e_j^*} = L_{e_j} + L_{e_{j+1}}$ , and  $D_{e_j^*} = D_{e_j}$ . Some parameter that will simplify the system of equations is  $L_{sh}$  – the minimum length of edge in the graph. If an arbitrary edge is shorter than  $L_{sh}$ , then it will be identified with the vertex. This reduces the number of edges, and, consequently, the number of equations. Choosing a value of  $L_{sh}$  one should be careful because the geometrical volume of the modified graph edges slightly differs from the original graph of GTS, and in order to do not change the topology significantly. With this in mind, it is also provided the functionality of this value assignment to individual edges that prevents these edges to be identified with vertices, even though  $L < L_{sh}$ . Therefore, for the valves (all types) that contain the condition on the change of the state (open/closed) there exists a global index indicating that the edges adjacent to the certain valve-edge do not undergo the process of the identification with vertices.

It should be also noted that some of the calculation parameters of the vertex  $v$  (pressure, or inflow/withdrawing of gas), which will be removed from the graph (in the case when the length of its

edge is zero or less than  $L_{sh}$ ), should be taken into account in the vertex of the beginning  $v_{beg}$  or the end  $v_{end}$  of the resultant edge  $e_R$ . The algorithm implements the rule of the vertex choice considering the distance to the corresponding vertices, i.e. if  $L(\overrightarrow{v, v_{beg}}) \leq L(\overrightarrow{v, v_{end}})$ , then the changes will be done in the vertex  $v_{beg}$ .

The system satisfies the following types of boundary conditions:

- 1) for facilities providing inflow or withdrawing of gas – for the gas flow rate and the gas pressure;
- 2) for CS – for the gas flow rate, inlet or outlet pressure, turnovers of centrifugal compressors, compression ratio, power of gas turbine drives (note that the type of boundary conditions for CS affects the partitioning technological scheme into cascades: in the case of conditions on the gas flow rate, inlet or outlet pressures, CS will be the cascade boundary (as well as closed valves, bypass), otherwise it belongs to this cascade);
- 3) for valves – for the state (closed/open).

#### 4. Regulation of objects operation

**Valves:** Turning the valve is instantaneous ( $Q = 0$ ). Opening the valve occurs with portioning the step with respect to the time variable. During this, the pressure drop  $\varepsilon$  tends to 1 ( $\varepsilon \rightarrow 1$ ) according to the following algorithm:

- we carry out the calculation of the pressure drop at the valve  $\varepsilon$  (available at the given time  $t$ );
- for the given time  $t$  (for all iterations of the given  $t$ ) the equation will include the compression ratio  $\varepsilon^*$ , which can be obtained from one of the formulae:  $\varepsilon^* = \varepsilon + \frac{1-\varepsilon}{29-n}$ , where  $n$  is the iteration number. For each iteration there is its portioned step after opening the valve,  $n = (0, \overrightarrow{9})$ .

**Compressor stations:** CS disconnection (“for passage”) occurs instantaneously, accounting for in the equations the compression ratio  $\varepsilon = 1$ . The connection of CS is performed during  $N_{On}$  steps, in the way of tending the compression ratio  $\varepsilon$  from  $\varepsilon_{\min}$  to a default value  $\varepsilon_{default}$ . Then, the CS operation mode is determined in the situation, and the CS power is fixed. ((Note, that at this instant it is adjusted the controlled parameter (CP) for the outlet pressure of CS  $P_2$ , if it exists, assigning the existing  $P_2$  as optimal).

Changing the CS power (increase or decrease) is performed proportionally to all shops, CS of which are working on a certain percentage  $\kappa$ . In this case,  $\kappa$  is determined as the percentage deviation of the CPU, which leads to a change of the CS operation from the optimal value (if the value of the controlled parameter is beyond of the technological/optimal permissible limits).

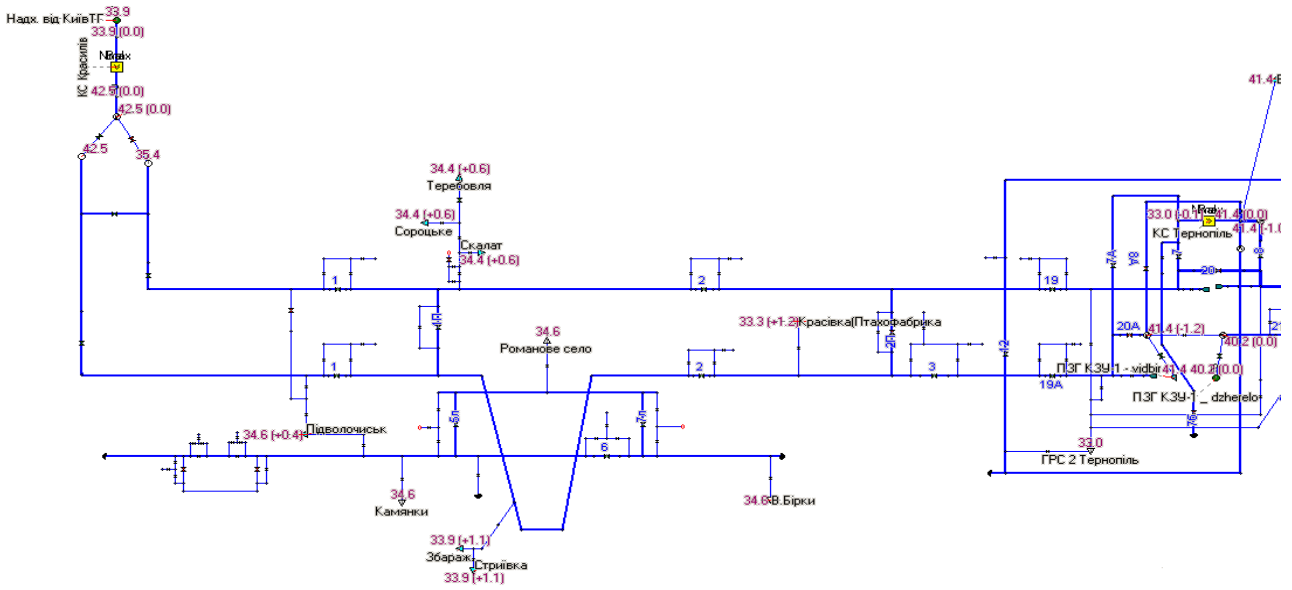
**Regulations of the system operation.** The table is formed, which is the regulations of the operation of the whole GTS. The table – Regulations of GTS objects operation – contains changes that take place in the GTS operation in chronological order, showing the previous value of the boundary condition, the type of the condition, the date of modification, name and code of the object. When you select an object in the list, it will be allocated and centred on the technological scheme (also it is available the context menu from which you can activate the box of input/removal/modification of the boundary conditions).

**Example 4.** Calculation of nonstationary regimes. A part of the technological scheme (Figure 8) of the real GTS is considered. Boundary conditions for both CS (input and output of the simulation system) are imposed on the gas pressure. Simulation was conducted for 10 hours, step-by time variable ( $\Delta t$ ) was taken to be equal to 600 s (10 minutes).

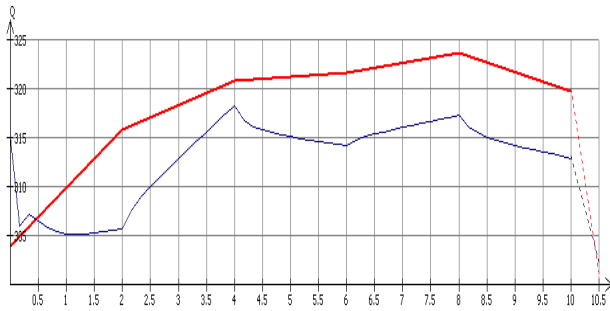
The results of simulation are shown in Figs. 9–12.

Having changed the boundary condition at Krasyliv CS for the gas volume flow rate, we obtain the following results of simulation:

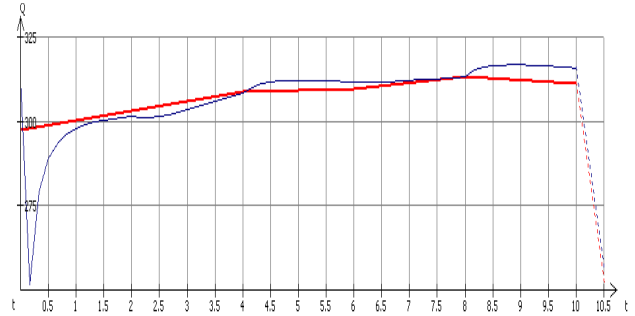




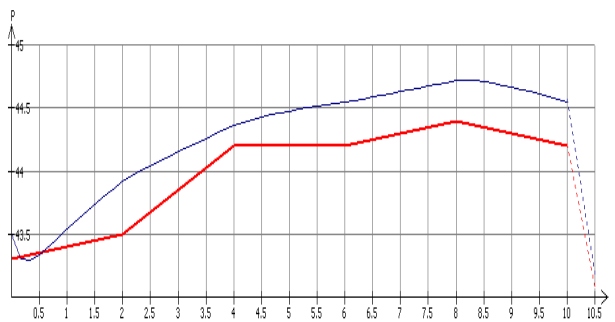
**Fig. 8.** Technological scheme of pipeline section Krasyliv CS (Khmelnytsky region) – Ternopil CS.



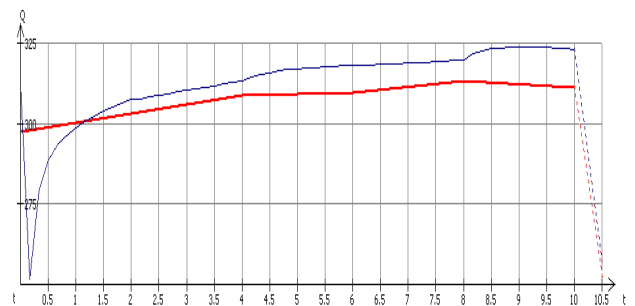
**Fig. 9.** Graphs of changes of the gas volume flow rate at Krasyliv CS (red – measured, blue – calculated).



**Fig. 10.** Graphs of changes of the gas volume flow rate at Ternopil CS (red – measured, blue – calculated).



**Fig. 11.** Graphs of changes of gas pressure at Krasyliv CS (red – measured, blue – calculated).



**Fig. 12.** Graphs of changes of the gas volume flow rate at Ternopil CS (red – measured, blue – calculated).

## 5. Conclusions

The suggested algorithms have been tested for a large number of real problems. Analysis of the results confirmed the efficiency of the algorithms. The calculation results deviate from measured ones by the value that is sufficient for modeling gas-dynamic processes having place in the gas transmission system.

- [1] Pankratov V. Automated system management of dispatcher management of GT. Moscow: "IRC Gazprom" (2002).
- [2] Sardanashvily S. Calculation methods and algorithms. Moscow: "Oil and Gas" (2005).
- [3] Seleznev V. Methods and techniques of numerical simulation of pipeline systems. Moscow: Editorial URSS (2002).
- [4] Bobrowski S. Pipeline transportation of gas. Moscow: Nauka (1976).
- [5] Sinchuk Yu., Prytula N., Prytula M. Simulation of valve operation on pipelines. Proceedings of the National University "Lviv Polytechnic": Computer Science and Information Technology. **663**, 216–222 (2010).
- [6] Sinchuk Yu., Prytula N., Prytula M. Simulation of unsteady regimes of gas networks. Proceedings of the National University "Lviv Polytechnic". Computer Science and Information Technology. **663**, 128–132 (2010).

## Моделювання нестационарних режимів роботи газотранспортних систем

Прытула Н. М.<sup>1,2</sup>, Гринів О. Д.<sup>2</sup>, Дмитрук В. А.<sup>1,3</sup>

<sup>1</sup>Центр математичного моделювання ІППММ ім. Я. С. Підстригача НАН України  
вул. Дж. Дудаєва 15, 79005, Львів, Україна

<sup>2</sup>ТОВ «Математичний центр»

вул. В. Великого 48, 79054, Львів, Україна

<sup>3</sup>Національний університет «Львівська політехніка»

вул. С. Бандери, 12, 79013, Львів, Україна

В роботі досліджено математичну модель газотранспортної системи. Приведені моделі газових потоків в основних технологічних об'єктах, які приймають участь в транспортуванні газу. Структура системи представлена в термінах теорії графів. Побудовано адаптивний алгоритм реалізації моделі газотранспортних систем і приведені реальні приклади його роботи.

**Ключові слова:** газотранспортна система, технологічна схема, модель газового потоку, режим роботи системи

**2000 MSC:** 35B; 65P

**УДК:** 621.64.029