

## A generic model of the information and decisional chain using Machine Learning based assistance in a manufacturing context

Mallouk I.<sup>1,2</sup>, Abou el Majd B.<sup>2</sup>, Sallez Y.<sup>1</sup>

<sup>1</sup>University Polytechnique des Hauts-de-France – LAMIH UMR CNRS n° 8201 F-59313 Valenciennes, France

<sup>2</sup>LMSA, FSR, Mohammed V University in Rabat, Morocco

(Received 26 May 2023; Revised 22 November 2023; Accepted 23 November 2023)

Nowadays, manufacturers must deal with huge international competition and continually improve their performances. In this context, several essential approaches namely CBM (Condition-based maintenance), PHM (Prognostics and Health Management), and PLM (Product Lifecycle Management) are used for manufacturing systems to maintain and increase their availability, reliability and performance. This implies that operational usage data of the manufacturing equipment must then be made available to all stakeholders concerned through efficient informational chains. However confronted with a large amount of data, the stakeholders must be assisted in their decision-making. This paper aims to propose a generic architecture that models the information and decision chain from the target system to the relevant stakeholders by assisting them in their decision-making. The proposed generic architecture is illustrated by a use case based on the LSTM (Long Short-Term Memory) algorithm in the context of energy management for a fleet of mobile robots.

**Keywords:** *manufacturing; decision-making; prognostic and health management (PHM); long short-term memory (LSTM).*

**2010 MSC:** 68P10, 68T35, 68U07, 68U35, 68P20

**DOI:** 10.23939/mmc2023.04.1023

### 1. Introduction and motivations

A system during its life cycle passes through three phases: Beginning of Life (BoL), Middle of life (MoL) and End of Life (EoL). During this time several human and/or artificial actors interact in the value chain from design to the final removal of the system. PLM is an approach to managing and modeling the lifecycle of a system, which has improved with the evolution of information systems and technologies [1, 2]. PLM provides stakeholders with a set of information that helps them to make appropriate decisions. This information allows us to locate and identify the parameters of the degradation and to understand the past, present and future of the considered system, denoted after the target system. In our works, a stakeholder is defined as any entity (human or artificial) in need of information/knowledge to make decisions to improve the value chain associated with the system [1].

Decision-making support systems, or simply decision support systems (DSS), are information systems designed to assist stakeholders and support one or all phases of a user's decision-making process. With the progress of Artificial Intelligence (AI) in the 1980s, AI tools were incorporated into DSS to increase the impact of management support. This led to the emergence of intelligent decision support systems (i-DSS) as a sub-discipline of DSS research [3]. A particular technology used within i-DSS research is Machine Learning (ML), which allows DSS to obtain new knowledge or to adapt to the user or changing environment. An i-DSS extends traditional DSS by incorporating techniques to supply intelligent behaviours and utilizing the power of modern computers to support and enhance decision making [4, 5]. The i-DSS may, for example, respond quickly to new data and information, deal with complex situations, learn from previous experience [6], use knowledge to understand the environment, recognize the relative importance of different elements in the decision and recommend actions [7, 8]. Most ML algorithms can be grouped into two main categories [9]: supervised learning and unsupervised learning. Depending on whether the data has labels or not. Supervised learning, which includes

predictive modeling and is applied to labeled data sets, can be subdivided into classification and regression algorithms depending on whether the target outcomes are categorical (classification) [10] or quantitative (regression) [11]. Unsupervised learning can be subdivided into clustering [12] and dimensionality reduction [13], depending on whether one wishes to group data into categories based on similarity, or simply reduce the dimensions of the input data. There are other types of ML algorithms, such as semi-supervised learning and reinforcement learning [9].

As argued in [14], often in a better way than traditional approaches, Machine Learning approaches can assist stakeholders in several facets: descriptive (give the current status of the equipment), diagnosis (explain past status), predictive (preview future status (e.g. Remaining Useful Life (RUL)) and prescriptive (recommend actions to maintain or improve system functionality).

In a manufacturing context, implemented on-board (i.e. on the equipment) or off-board, these approaches aim to give decision-making assistance to users situated in the vicinity of the equipment (e.g. machine operator) or for more distant stakeholders (e.g. maintenance responsible, production manager). However, most works that deal with decision support through ML focus on a particular domain without offering a global vision. This limitation is often justified by the fact that each domain has its technical specifications, especially in terms of data structure. The present work proposes a generic architecture that takes into consideration the target system and its environment. This architecture aims to provide analytical assistance to the different stakeholders that have an interest in the target system. The second section will be dedicated to a state of the art that explores several works in the manufacturing domain and identify some shortcomings. The third section is dedicated to the proposal of a generic architecture that models the information and decision chain from the target system to the different stakeholders. In the end, a manufacturing use case is presented to validate our proposal.

## 2. Related works

Due to the progress of technologies and in particular IoT sensors, the data of companies and manufacturers has grown. The variety of sensors and actors leads to a Big Data context, which complicates the decision-making process [15]. To deal with this, analytics tools, especially the ML-Based approach, can be applied to extract useful insights from the data. The following works are chosen as they offer decision support to the stakeholders of the target system. They propose architecture examples for use cases in the manufacturing domain.

To estimate the Health Index (HI), the work [16] proposed ‘Embed-RUL’ methodology for predicting the RUL of a turbofan engine. They embedded time series data using Recurrent Neural Network (RNN) as an encoder and drew a HI curve with it. Then, the RUL is predicted by comparing the latter curve with the normal HI curve. That methodology is a useful approach when sensor data have noise and missing values, or when there is insufficient prior knowledge of machine degradation trends. The results of the work provide a predictive approach that will be used by the maintenance department for supervision purposes.

The authors of [17] presented Deep Neural Networks to predict the State of Health (SoH) and RUL of Lithium-ion batteries, moreover, the proposed DNN was compared against other machine learning algorithms. This work is part of both the diagnostic facet because it gives a vision of the past, and also the predictive facet because it gives a projection into the future with the estimation of the RUL. With this double facet, stakeholders (e.g. Maintenance department) can plan the replacement of batteries at the right time.

In the area of Mobile Robots, the work [18] describes an approach that uses ML to find a set of Pareto-optimal configurations in a large configuration space which is then used to identify the best reconfiguration (e.g., to a less energy-demanding configuration) and change the path (e.g., to reach a charging station). The paper considers mobile robots in the context of cyber-physical systems; the optimal configuration obtained for the individual dimension can be reused for the fleet of mobile robots.

The assistance analytics used in this work can therefore be exploited on-board (at the individual level) and off-board (at the fleet level).

In a PHM approach, the authors of [19] introduced a method based on an unsupervised variable selection method and  $k$ -nearest neighbors (KNN) classifier. The method builds on the unsupervised selection of interesting variables from the input offline signals. It constructs representative features that can be used as health indicators of bearing. The results can be used individually to describe or predict the situation of a machine using the bearings, as well as being used off-board by the maintenance center managing several machines. The authors of [20] worked on a refrigeration and cold storage system by developing an ML base approach that detects early faults in the machinery involved in the refrigeration. They apply a feature extraction step in the pre-processing phase of the model, which consisted of learning the pattern of the dataset and seasonality decomposition by dynamic time wrapping and clustering. They also built a Random Forest classifier to recognize if the pattern was abnormal or not. This work is part of the diagnostic facet. This approach can be applied to the whole fleet (e.g. supermarket network) and stakeholders can then detect refrigerator faults in advance and therefore plan preventive maintenance.

In a manufacturing context and to build a condition monitoring system, the work [21] devised an unsupervised  $k$ -Means clustering approach to subgroup the health condition of a machine tool into four categories: normal operations, faulty conditions due to pressure systems, faulty conditions due to protection gas, and faulty conditions keeping the machine in a standby mode. In the same vision, the authors of [22] used an artificial neural network (ANN) to classify the condition of a CNC machine, but for this work, by taking into account the real-time data loaded from this machine. They built a database and then designed an ANN model.

In the work [23] recurrent neural networks (RNN) are applied. In this case, the authors use the RNN to generate a predictor of future usage scenarios (e.g. path to follow) of resources in manufacturing context. To obtain the schedule, information about the current state of the production process is provided in real-time. This information is then filtered and processed by RNN, to estimate the near-future scenario, and this feeds the optimizer that determines the schedule.

The previously presented works are summarized (see Table 1) according to the following key elements: the target system, the objective of the work, decision-making facets adopted, the approach used, and the level of processing where the analytics assistance is applied.

**Table 1.** Research works summary.

Authors	Target system	Objective	Decision-making facets	Approach used	Treatment level	Stakeholder
[16]	Turbofan Engine	Health Index RUL estimation	Predictive	Recurrent Neuralnetwork (RNN)	Off-board	Maintenance department
[17]	Lithium-ion battery	State of Health / RUL	Diagnosis/ Predictive	Deep Neural Network algorithm (DNN)	Off-board	Maintenance department
[18]	Mobile Robots	Power consumption	Prescriptive	Stepwise linear regression	On-board Off-board	Mobile Robots Fleet manager
[19]	Bearing	Health Index / RUL estimation	Descriptive / Predictive	$k$ -nearest neighbors ( $k$ -NN) Discrete Bayesian	On-board Off-board	Machine manufacturers
[20]	Refrigeration Systems	Failures detection	Diagnosis	Random Forest (RF)	Off-board	Maintenance department
[2]	Laser Melting Machine	Fault detection Condition monitoring	Diagnosis	$K$ -means	On-board	Machine manufacturers
[22]	CNC machine	Monitoring System	Diagnosis	Artificial Neural Network (ANN)	On-board Off-board	Maintenance department
[23]	Resources in manufacturing context	Predicting resource performances	Predictive Prescriptive	Big Data technics LTSM	On-board Off-board	Production manager

Although these studies are relevant, they do not provide a generic model for decision making with ML-based assistance. Moreover, the majority of these approaches concern the “off-board” location. The generic model must deal with several requirements:

- Req#1: the complexity of manufacturing equipment (e.g. machine-tools, robots), seen as a system composed of several sub-systems;
- Req#2: the various needs of the stakeholders implied in the manufacturing task;
- Req#3: the “off-board” and “on-board” locations should be considered in the same model.

### 3. Proposition

#### 3.1. Generic model

The proposed generic model is inspired by previous modeling works based on primary and secondary functions [1, 24, 25]. Primary functions represent activity (e.g. milling, assembly) associated with the manufacturing equipment, while secondary functions are dedicated to improve the performance criteria associated with the primary functions (e.g. Condition-based maintenance, Monitoring of the mobile robots fleet). Figure 1 illustrates an application of the model on an industrial mobile robot. This last is considered as a target system denoted  $S_i$  (1) immersed in a context  $C_i$ , composed of the users (2) (e.g. local operators), the task (3) Characterized by prescribed procedures (i.e., how the transportation task must be performed) and some performance criteria (e.g., energy consumption, operation time) representative of the primary function, and the environment (4) which may be physical (e.g. outside temperature, humidity) or non-physical (e.g. machinery safety legislation).

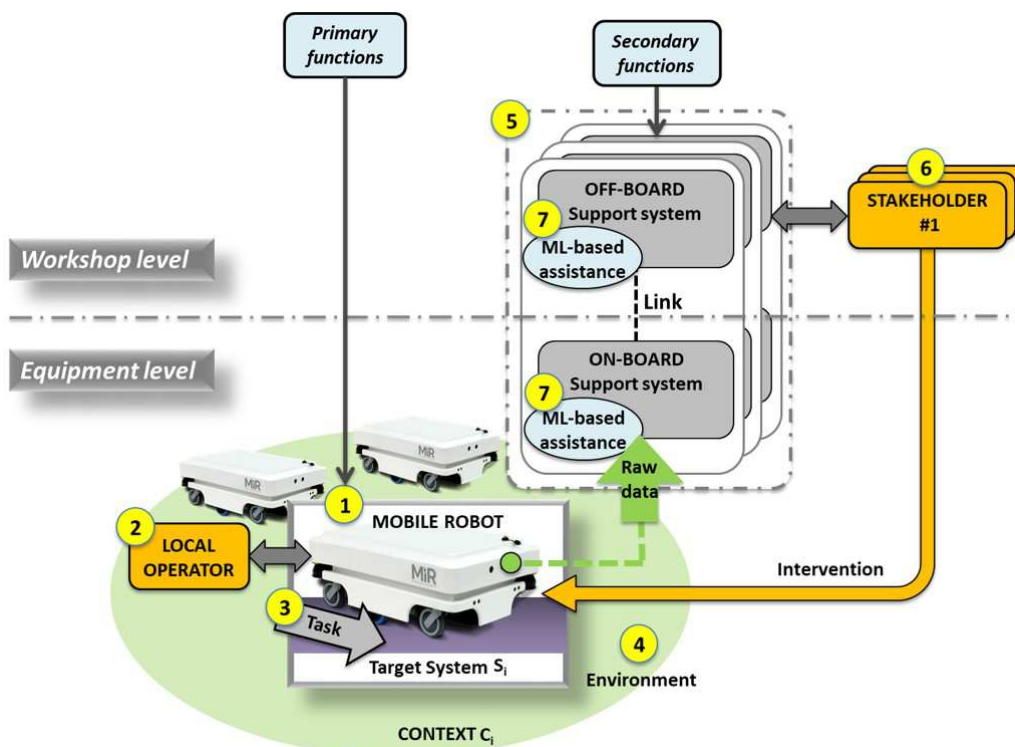

Fig. 1. Illustration of the modeling.

To fulfil the requirements #2 and #3, the secondary functions are handled by support systems (5) at two levels:

- At the Equipment level, a set of secondary functions is supported by on-board support systems which exploit the raw data flow collected by sensors and instrumentation (e.g. vibration sensors) associated with the system  $S_i$ . They generated refined and accurate information (e.g. diagnosis if failure) sent to off-board support systems (e.g. remote maintenance center).

— At the Workshop level, the remaining secondary functions are supported by off-board support systems. They generate expertise results, taking into account the experience on the manufacturing equipment (and eventually of a collective of similar equipment), to the implied stakeholders (6) (e.g. Production manager, Maintenance manager) that can then schedule adequate interventions on the manufacturing equipment or its context.

For each secondary function, decisional processes can be assisted by ML approaches (7), as detailed in the next section.

### 3.2. Decisional process assisted by machine learning techniques

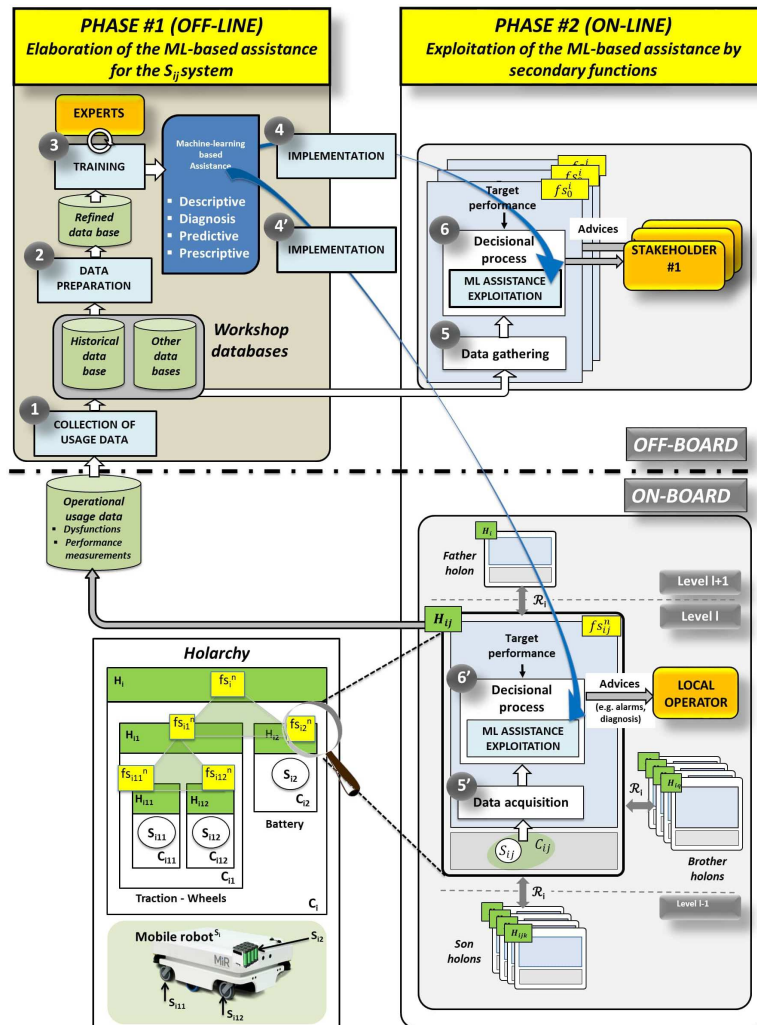

Fig. 2. Illustration of the modelling.

To fulfill the requirement #1, the holonic modeling paradigm [26, 27] is retained to deal with the decomposition of a system  $S_i$  in several sub-systems that may themselves be decomposed into sub-systems (see lower left part of Figure 2). This paradigm has already proved its worth, especially for control [28, 29] and also for the maintenance of composite systems (i.e. decomposable into a set of sub-systems) [30]. A triplet  $(Fs_i, S_i, C_i)$  is associated with each holon  $H_i$ . The set  $Fs_i$  of secondary functions, the system  $S_i$  and its context  $C_i$  constitute the head and the body of the holon, respectively. As detailed in [1, 25], collaborative relationships exist among holons located on successive levels and allow information flow in the holarchy. For example, for a sub-system, false alarms can be filtered by taking into account the context and the condition of the other similar sub-systems [30]. Figure 2 illustrates the development of an assistance (based on ML technics) exploited by decisional processes

associated with several secondary functions. The successive steps of this development are depicted by circled labels and are organized in two phases as classically proposed in ML approaches [31, 32].

**Phase #1 (off-line):** The goal of this phase is to exploit the global information available off-board to build pertinent assistance for a specific equipment (e.g. Sij system in Figure 2) aiming to help the different stakeholders in their decision-making. Four steps are distinguished: *Data collection (1)*: The operational usage data, issued from the equipment on-board, are collected to enrich a historical database. The evolution of sensor technology helped to capture several measurements (e.g. pressure, temperature, vibrations, ...). This raw data is time-stamped (e.g. time series) to create a historical database that makes the next steps easy to perform. *Data preparation (2)*: This step exploits the historical database (i.e. data obtained from the different similar systems including their contexts) (1) and other databases available at the workshop level (e.g. history of maintenance interventions, production history). Statistical methods can then be used to reduce the size of the features in the data by keeping only the significant variables relative to the aimed assistance and generating a refined database [33]. *Training (3)*: This step is crucial to develop the ML-based assistance exploiting the previous refined database [34, 35]. After the choice of an adequate ML algorithm [9, 36], an expert of the considered Sij system (e.g. maintainer specialist) can be employed for the ML algorithm training. The generated assistance can be of descriptive, predictive, diagnosis or prescriptive type. *Implementation*: This step is dedicated to the implementation (or the update) of the ML-based assistance off-board (4) or/and on-board (4').

**Phase #2 (on-line):** This phase is relative to the exploitation of the obtained ML-based assistance according to two steps: *Data collection*: This step aims to provide relevant data to the ML-based assistance. Off-board, it concerns the gathering, preparation, and reduction of some relevant workshop data (5). On-board, it concerns the acquisition of raw data (5') on the focused Sij system (e.g. batteries voltage) and its context Cij (e.g. external temperature). *Exploitation of the ML-based assistance for decision-making*: The collected data are then exploited by the previously designed ML algorithm integrated into the decisional processes associated with the secondary functions located off-board (6) or on-board (6'). Pertinent advice is then generated to the stakeholders (e.g. prognosis on the RUL of a sub-system) or the operators (e.g. possible cause of a failure). The successive steps of this generic model are validated through the following case study in a manufacturing context.

#### 4. Use case

The use case concerns the PHM of a fleet of mobile industrial robots powered by packs of lithium-ion batteries (see Figure 6). Monitoring the condition of these batteries is crucial to ensure the good availability of the fleet. The aim is to provide the different stakeholders (e.g. maintenance manager, production manager, ...), with a clear view of the conditions of use of mobile robots. In particular, the state of their batteries is important to make reliable decisions (e.g. plan battery replacement, plan additional missions, ...). This decision-making will be supported by ML-based assistance.

Two phases (section 3.2) are addressed, the off-line phase which concerns the preparation of the data and the development of the ML model (e.g. RUL model), and the on-line phase which concerns the use of the model generated by one or more stakeholders as well as analytics assistance for decision making.

**Phase #1 (off-line):** The goal of this phase is to exploit the global information available off-board to build pertinent assistance aiming to help the different stakeholders in their decision-making. The objective of this phase is to prepare the data to launch the learning process. Four steps are distinguished:

*Data collection (1)*:

The present study exploits a dataset of the Prognostics Center of Excellence (PCoE) database at NASA Ames [29]. It contains four different Li-ion batteries (#5, #6, #7, and #18), and each Li-ion battery repeats three operations (charge, discharge, and impedance measurements) at room temperature (24 °C). The test conditions of the NASA battery are listed in Table 2.

**Table 2.** NASA battery dataset.

Cycle	AMBIENT TEMP C°	DATETIME	CAPACITY	VOLTAGE	CURRENT	BATTERY TEMP (C°)	CURRENT (Amps)	VOLTAGE (Vols)	TIME
1	24	02/04/2008 15 : 25 : 41	1.891052	4.199360	0.001866	23.937044	-0.0004	0.000	0.000
1	24	02/04/2008 15 : 25 : 41	1.891052	4.199497	0.002139	23.924074	-0.0004	4.215	16.781
1	24	02/04/2008 15 : 25 : 41	1.891052	3.985606	1.988778	24.004257	-2.0000	3.003	35.703
1	24	02/04/2008 15 : 25 : 41	1.891052	3.963247	1.992558	24.162868	-2.0000	2.987	53.781
1	24	02/04/2008 15 : 25 : 41	1.891052	3.946647	1.988491	24.346368	-2.0000	2.972	71.922

The charge process consists of constant current (CC) mode and constant voltage (CV) mode. In the charge in CC mode, the current is kept at 1.5 A until the Li-ion battery voltage is increased to 4.2 V. In the charge CV mode, the voltage holds 4.2 V until the Li-ion battery current drops to 20 mA from 1.5 A. In the whole charge process, the battery terminal voltage, battery output current, battery temperature, measured current, and measured voltage are recorded. The discharge process belongs to the CC mode, and the current is 2 A until the Li-ion battery voltage drops to 2.7 V from 4.2 V. In the discharge process, the recorded variables (except battery capacity) are the same as those of the charging process. As time goes on, the repeated charge and discharge process results in accelerated degradation, and eventually, the end of the battery's service life (EoL).

Our study concerns the discharge behaviour of batteries. The following graph shows the battery's degradation process over the charge cycles. The horizontal line represents the threshold for what can be considered the end of life of the battery.

*Data preparation (2):*

Typically, the End of Life (EoL) model of the Li-ion battery is closely related to the battery capacity. The specific Li-ion battery remaining capacity model can be acquired in the literature [27]. This model gives all parameters (except some constant coefficients) by various experimental curve fittings. Despite knowledge of the complicated Li-ion mechanisms, the State of Health (SoH) can be defined as:

$$SoH(d) = \frac{C(\tau)}{C(0)},$$

where  $C(0)$  is the capacity value at the initial stage of the Li-ion battery, and  $C(\tau)$  is the capacity value at time  $t$  (it is usually the index of cycle number). In the literature [37], at 70% the battery is assumed to be at the end of its life. The horizontal line represents the 70% threshold at which the battery reaches its life cycle and it is recommended to change it.

For the prediction of the RUL of the batteries, the training and test data set is prepared in such a way that the first 50 cycles are used as training data. The projection into the future is done on the rest of the cycles until the EoL of the batteries is reached.

*Training (3):* As mentioned at the beginning, we are interested in proposing a generic model that models the information and decision chain from the system to the stakeholders via analytical support based on Machine Learning. For this purpose, several techniques and methods can be used for the training process. These techniques can be divided into two categories: model-based methods [38] and data-based methods [39].

Model-based methods mainly consist of analyzing the physical and chemical principles of the battery and establishing mathematical and physical models to characterize the performance degradation process of the lithium-ion battery.

Data-driven methods have recently received much attention in the lithium-ion battery domain. Compared with other types of data-based methods, neural network, especially deep neural network, can approximate the complex nonlinear model infinitely by forming multilayer neural networks and achieve better accuracy for prediction.

In our use case, and in the vision of validating the proposed generic model, we use the Long Short-Term Memory (LSTM) algorithm. The choice is motivated by the literature [40]. LSTM is more suitable for time series prediction which characterizes our battery dataset [40–42]. Compared with RNN, has the advantage that it can manage the information in memory for a long period of time, in contrast to the RNN [42]. RNNs have feedback loops in the recurrent layer. This lets them



maintain information in “memory” over time. But, it can be difficult to train standard RNNs to solve problems that require learning long-term temporal dependencies. For the reason that the gradient of the loss function decays exponentially with time (called the vanishing gradient problem). The long-range dependency in RNN is resolved by increasing the number of repeating layers in LSTM [41]. In the following section, the LSTM operating process is detailed.

#### 4.1. The basic LSTM architecture

LSTM was first proposed in 1997 [43]. LSTM is a modified network of RNN proposed to learn long-range dependencies across time-varying patterns (trend and seasonality). Generally, LSTM is the second order recurrent neural network that solves the vanishing gradients issue by replacing RNN simple units with the memory blocks in the recurrent hidden layer. A memory block is a complex processing unit in LSTM with many units. It is composed of one or many memory cell, adaptive multiplicative gating units (input, output and forget) and a self-recurrent connection with a fixed weight. It serves as a short-term memory with a control from adaptive multiplicative gating units. The input and output flow of a cell activation of a memory cell is controlled by input and output gate respectively. Forget gate was included in memory cell that helps to forget or reset their previous state information when it is inappropriate. Moreover, peephole connections between cells to all of its adaptive multiplicative gates control the precise timing of outputs including the internal states.

The basic LSTM architecture predictor is shown in Figure 3. Here,  $x_t$  is the input at the current time step,  $h_{t-1}$  stands for the output at the previous time step, and  $C_{t-1}$  is the cell memory at the previous time step;  $h_t$  stands for the output at the current time step, and  $C_t$  is the cell memory at the current time step. The red line (Figure 3) can maintain information transfer and not change the information through the whole cell state, which is the key to LSTM.

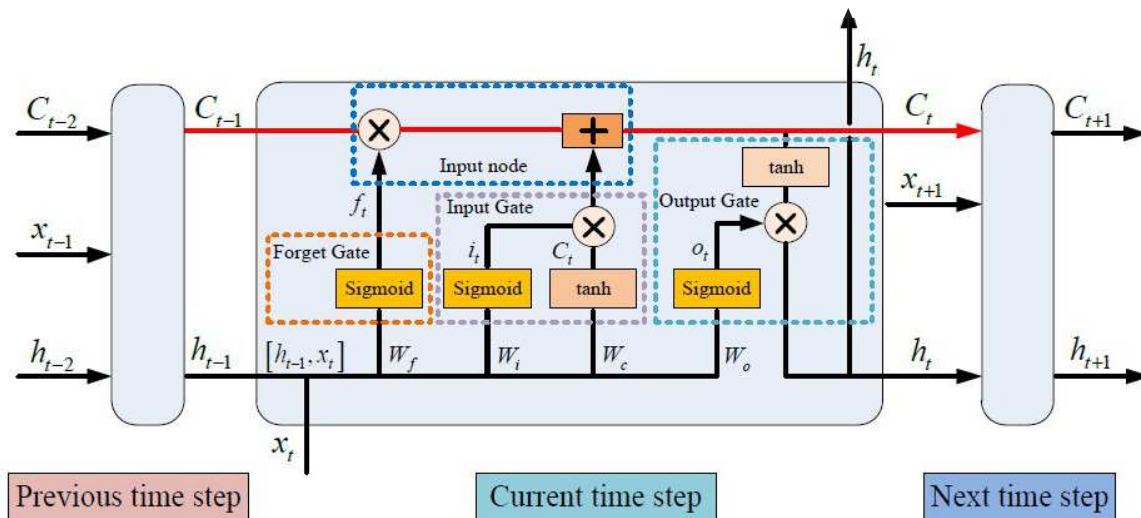

Fig. 3. LSTM principle pipelines [40].

*Remove Unnecessary Information:* The first step is to use the forget gate to determine how much information of last cell state  $C_{t-1}$  will be stored in the current cell state  $C_t$ . There are three types of input data of forget gate: the cell state  $C_{t-1}$  of the last step, the hidden state  $h_{t-1}$  of the last step, and the current input  $x_t$ . Forget gate outputs a sequence of 0 (discarded information) and 1 (retained information).  $\sigma$  is a sigmoid function. The forget gate is calculated as follows:

$$f_t = \sigma(W_f \cdot [h_{t-1}, x_t] + b_f).$$

*Calculating New Cell:* The input gate is used to determine how much new information can be added to LSTM cell state. There are two parts of the input gate: a sigmoid layer, i.e.,  $i_t$ , which can determine what information should be updated, and a  $\tanh$  layer which can generate a vector  $\tilde{C}_t$  for updating. The equations to calculate two outputs are



$$i_t = \sigma(W_i \cdot [h_{t-1}, x_t] + b_i),$$

$$\widetilde{C}_t = \tanh(W_c \cdot [h_{t-1}, x_t] + b_c).$$

Then,  $C_{(t-1)}$  is multiplied by the  $f_t$  which is the result of forget gate and then the product of  $i_t$  and  $\widetilde{C}_t$  is added. The new state value  $C_t$  can be obtained by

$$C_t = f_t \cdot C_{t-1} + i_t \cdot \widetilde{C}_t.$$

*Output Result:* The final output of the LSTM Cell is determined by the output gate. There are two kinds of output values. One is current state  $C_t$  and the other is current hidden state  $h_t$ . The equations are as

$$o_t = \sigma(W_o \cdot [h_{t-1}, x_t] + b_o),$$

$$h_t = o_t \cdot \tanh(C_t).$$

### 4.2. Evaluation criterion

Once the model had been trained, the performance of the resulting model was evaluated using different indicators: the Root Mean Square Error (RMSE) and  $R^2$ ,

$$RMSE = \sqrt{\sum_i^n \frac{(X_i - Y_i)^2}{n}},$$

$$R^2 = 1 - \left( \frac{\sum_i^n (X_i - Y_i)^2}{\sum_i^n (X_i - \bar{X}_i)^2} \right)^2,$$

where  $X_i$  is the real information for each  $i$  from 1 to  $n$ ;  $Y_i$  is the predicted information;  $n$  is the predicted period.

RMSE is one of the evaluation criterion of a regression model. It is a metric that indicates the average distance between the values predicted by the model and the real values in the dataset. The lower the RMSE, the better a given model is able to fit a dataset. R-Squared ( $R^2$ ) measures the degree of correlation between two variables in such a model.

### 4.3. The resulting analytics model

For the training process, the parameters of the model, as detailed in Table 3, are for the neuron and the factor for dropping the learning rate are set to 200, 0.3 respectively. The LSTM model is used to predict the time series from the 50th cycle. Finally, the obtained learning model is used to predict the Li-ion batteries sub-dataset for the test. The RUL is calculated as a function of the failure threshold (described above is set at 70%).

The prediction of the SoH is trained on the data from the B0007 battery. The prediction results of the model on the same battery give an RMSE of 0.000994 which is very close to the real data Figure 4a. We tested the prediction model obtained with another battery (B00018), in order to evaluate the performance of the model. An RMSE of 0.016 is obtained Figure 4b.

The prediction model applied to the test data from the 50th cycle gives an RI of 0.94 and an RMSE of 0.032. This result translates into a difference of just 5 cycles between the actual number of cycles before the EoL and the predicted number of cycles of the EoL (Figure 5), taking into account the EoL threshold at 1.4 Ah.

**Table 3.** Model parameters used for the learning process.

Layer (type)	Output Shape
lstm 16 (LSTM)	(None, 10, 200)
dropout 18 (Dropout)	(None, 10, 200)
lstm 17 (LSTM)	(None, 10, 200)
dropout 19 (Dropout)	(None, 10, 200)
lstm 18 (LSTM)	(None, 10, 200)
dropout 20 (Dropout)	(None, 10, 200)
lstm 19 (LSTM)	(None, 200)
dropout 21 (Dropout)	(None, 200)
dense 12 (Dense)	(None, 1)

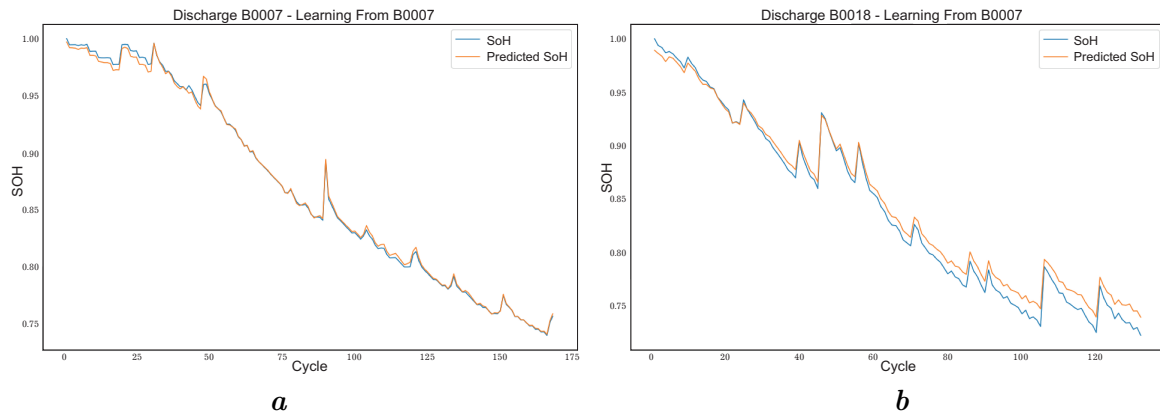

**Fig. 4.** (a) Discharge of B0007, learning from B0007; (b) Discharge of B0018, learning from B0007.

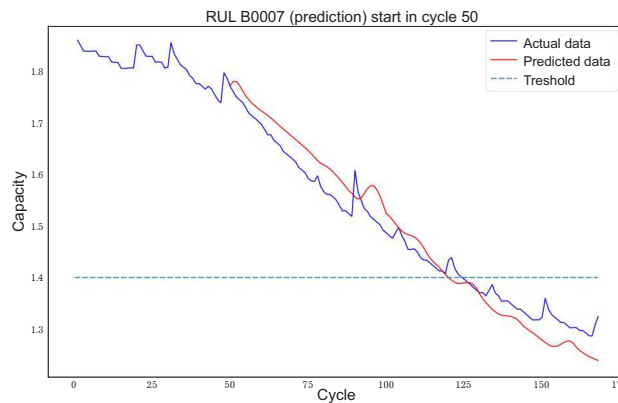

**Fig. 5.** Actual vs Predicted RUL.

#### 4.4. Implementation (4)

This step is dedicated to the implementation (or the update) of the ML-based assistance off-board or/and on-board. In this step, the obtained analytics model will be transferred to the different analytics assistants to use it in a real context and with live data. At each level, on-board or off-board, the analytics assistant will help the decision process to serve the stakeholder in the end. The next step explains this process.

**Phase #2 (on-line):** This phase is relative to the exploitation of the obtained ML-based assistance according to two steps: *Data collection:* The data collection in the on-line phase concerns real-time data about the mobile robots. The learning model uses data from the target system (i.e. SoH of the battery of mobile robots) and its environment (e.g. room temperature). In our use case, we remain focused on the dataset presented above. However, other data from the off-board level can be used such as the future missions to be performed and the task to be executed by the mobile robot.

*Exploitation of the ML-based assistance for decision-making:* The collected data are then exploited by the previously designed ML algorithm integrated into the decisional processes associated with the secondary functions located off-board or on-board. Pertinent advice is then generated to the stakeholders (e.g. prognosis on the RUL of a sub-system) or the operators (e.g. possible cause of a failure). As shown in Figure 6, the data collected from the Equipment level (e.g. voltage, current, temperature) are merged with the data issued from other batteries.

The RUL prediction is exploited “off-board” by several secondary functions. A first secondary function uses it to evaluate the availability of the mobile robots fleet according to the states of the battery packs and generate advice to the production manager. Another secondary function exploits predictively the estimated batteries RUL to optimize the maintenance operations according to a CBM approach [44]. The implemented RUL prediction is used “on-board” by the mobile robot to give recommendations to the operator (e.g. avoid a too longer mission).

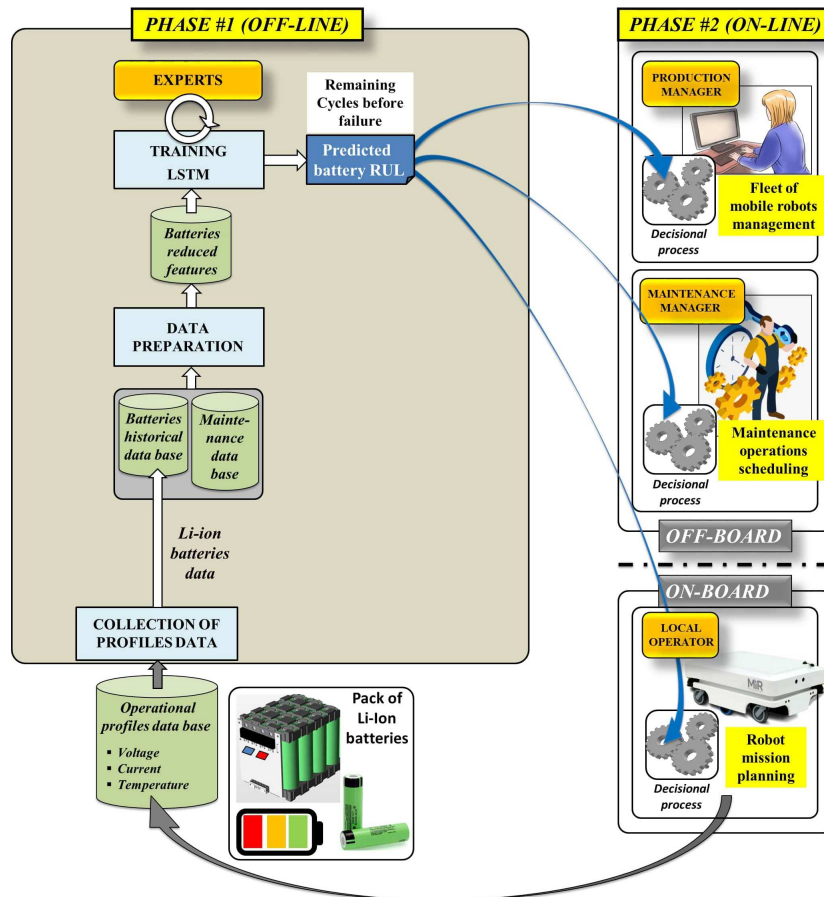

Fig. 6. Batteries management.

## 5. Conclusion

In this paper, we proposed a generic model of the information and decisional chain, exploiting ML-based assistance, between a manufacturing equipment and the concerned stakeholders. The literature review has shown that few architectures propose a generic model and take into account the needs of stakeholders at several levels of processing. By addressing the requirement of manufacturing complexity, the requirement of satisfying the needs of stakeholders and the requirement of the different levels of treatment; two phases “off-line” and “on-line” have been proposed to develop ML-based assistance for the decision-making. A use case, in the context of energy management for a fleet of mobile robots, has illustrated the proposal. SoH monitoring and RUL prediction are two important needs that stakeholders face in the PHM of lithium-ion batteries. In this paper, we used the LSTM algorithm to create an analytics assistance to monitor the SoH and to calculate the RUL prediction of mobile robot batteries.

According to the evaluation criteria, the obtained result is considered relevant and the assistance analytics can be reused by several departments at the on-board and/or off-board level as explained in the last section. Machine learning techniques have obtained remarkable achievements in various tasks, such as image recognition, object detection, and language modeling. However, building a high-quality ML system for a specific task highly relies on human expertise, hindering its wide application [45, 46]. Meanwhile, automated machine learning (AutoML) is a promising solution for building a ML system without human intervention. This approach can be used in the process model generation for the choice of the adequate algorithm without human intervention [36, 47].

The next step will concentrate on implementing the AutoML for the generation of assistance analytics in a vision of cooperation between humans and machine.

Mid-term perspectives will aim to realize the development of efficient interfaces to present the results provided by the ML-based assistance to the different stakeholders.

**Data Availability Statement:** The NASA's batteries data can be found at <https://c3.ndc.nasa.gov> (accessed on 26 May 2023). The rest data used to support the findings of this study are available from the corresponding author upon request.

- 
- [1] Basselot V., Berger T., Sallez Y. Information chain modeling from product to stakeholder in the use phase – Application to diagnoses in railway transportation. *Manufacturing Letters*. **20**, 22–26 (2019).
  - [2] Kiritsis D. Closed-loop PLM for intelligent products in the era of the Internet of things. *Computer-Aided Design*. **43** (5), 479–501 (2011).
  - [3] Merkert J., Mueller M., Hubl M. A survey of the application of machine learning in decision support systems. *ECIS 2015 Completed Research Papers*. 133 (2015).
  - [4] Parnell G. S., Driscoll P. J., Henderson D. L. *Decision Making in Systems Engineering and Management*. John Wiley & Sons, Inc. (2011).
  - [5] Bosse E., Solaiman B. Fusion of information and analytics: a discussion on potential methods to cope with uncertainty in complex environments (big data and IoT). *International Journal of Digital Signals and Smart Systems*. **2** (4), 279–316 (2018).
  - [6] Murty K. G., Kim W.-J. An iDMSS Based on Bipartite Matching and Heuristics for Rental Bus Allocation. *Intelligent Decision-making Support Systems*. 219–235 (2006).
  - [7] Wallace W. A., De Balogh F. *Decision Support Systems for Disaster Management*. **45**, 134–146 (1985).
  - [8] Glasspool D. W., Fox J., Castillo F. D., Monaghan V. E. L. Interactive decision support for medical planning. *Conference on Artificial Intelligence in Medicine in Europe. AIME 2003: Artificial Intelligence in Medicine*. 335–339 (2003).
  - [9] Ayodele T. O. *Types of Machine Learning Algorithms*. *New Advances in Machine Learning* (2010).
  - [10] Soofi A. A., Awan A. *Classification Techniques in Machine Learning: Applications and Issues*. *Journal of Basic & Applied Sciences*. **13**, 459–465 (2017).
  - [11] Maulud D. H., Abdulazeez A. M. A Review on Linear Regression Comprehensive in Machine Learning. *Journal of Applied Science and Technology Trends*. **1** (4), 140–147 (2020).
  - [12] Ezugwu A. E., Ikotun A. M., Oyelade O. O., Abualigah L., Agushaka J. O., Eke C. I., Akinyelu A. A. A comprehensive survey of clustering algorithms: State-of-the-art machine learning applications, taxonomy, challenges, and future research prospects. *Engineering Applications of Artificial Intelligence*. **110**, 104743 (2022).
  - [13] Van der Maaten L., Postma E., van den Herik J. *Dimensionality Reduction: A Comparative Review*. *Dimensionality Reduction: A Comparative Review*. Tilburg centre for Creative Computing, Tilburg University (2009).
  - [14] Barua L., Zou B., Zhou Y. Machine learning for international freight transportation management: A comprehensive review. *Research in Transportation Business & Management*. **34**, 100453 (2020).
  - [15] Power D. J. Using Big Data for analytics and decision support. *Journal of Decision Systems*. **23** (2), 222–228 (2014).
  - [16] Gugulothu N., TV V., Malhotra P., Vig L., Agarwal P., Shroff G. Predicting Remaining Useful Life using Time Series Embeddings based on Recurrent Neural Networks. Preprint arXiv:1709.01073 (2021).
  - [17] Khumprom P., Yodo N. A data-driven predictive prognostic model for lithium-ion batteries based on a deep learning algorithm. *Energies*. **12** (4), 660 (2019).
  - [18] Jamshidi P., Camara J., Schmerl B., Kaestner C., Garlan D. Machine learning meets quantitative planning: Enabling self-adaptation in autonomous robots. *2019 IEEE/ACM 14th International Symposium on Software Engineering for Adaptive and Self-Managing Systems (SEAMS)*. 39–50 (2019).
  - [19] Mosallam A., Medjaher K., Zerhouni N. Data-driven prognostic method based on Bayesian approaches for direct remaining useful life prediction. *Journal of Intelligent Manufacturing*. **27** (5), 1037–1048 (2016).
  - [20] Kulkarni K., Devi U., Sirighee A., Hazra J., Rao P. Predictive Maintenance for Supermarket Refrigeration Systems Using only Case Temperature Data. *2018 Annual American Control Conference (ACC)*. 4640–4645 (2018).

- [21] Uhlmann E., Pontes R. P., Geisert C., Hohwieler E. Cluster identification of sensor data for predictive maintenance in a Selective Laser Melting machine tool. *Procedia Manufacturing*. **24**, 60–65 (2018).
- [22] Krishna K. M., Kannadaguli P. IoT based CNC machine condition monitoring system using machine learning techniques. 2020 IEEE 9th International Conference on Communication Systems and Network Technologies (CSNT). 61–65 (2020).
- [23] Morariu C., Morariu O., Răileanu S., Borangiu T. Machine learning for predictive scheduling and resource allocation in large scale manufacturing systems. *Computers in Industry*. **120**, 103244 (2020).
- [24] Sallez Y., Berger T., Deneux D., Trentesaux D. The lifecycle of active and intelligent products: The augmentation concept. *International Journal of Computer Integrated Manufacturing*. **23** (10), 905–924 (2010).
- [25] Mallouk I., Berger T., Abou El Majd B., Sallez Y. A Proposal to Model the Monitoring Architecture of a Complex Transportation System. *International Workshop on Service Orientation in Holonic and Multi-Agent Manufacturing. SOHOMA 2020: Service Oriented, Holonic and Multi-Agent Manufacturing Systems for Industry of the Future*. 532–542 (2021).
- [26] Koestler A. Beyond Atomism and Holism the Concept of the Holon. *Perspectives in Biology and Medicine*. **13** (2), 131–154 (1970).
- [27] Koestler A. *The Ghost in the Machine*. New York, Macmillan (1968).
- [28] Indriago C., Cardin O., Rakoto N., Castagna P., Chacòn E. H<sup>2</sup>CM: A holonic architecture for flexible hybrid control systems. *Computers in Industry*. **77**, 15–28 (2016).
- [29] Cardin O., Derigent W., Trentesaux D. Evolution of holonic control architectures towards Industry 4.0: A short overview. *IFAC-PapersOnLine*. **51** (11), 1243–1248 (2018).
- [30] Le Mortellec A., Clarhaut J., Sallez Y., Berger T., Trentesaux D. Embedded holonic fault diagnosis of complex transportation systems. *Engineering Applications of Artificial Intelligence*. **26** (1), 227–240 (2013).
- [31] Murphy K. P. *Machine Learning: A Probabilistic Perspective*. MIT Press (2012).
- [32] Mbuli J., Nouri M., Trentesaux D., Baert D. Root causes analysis and fault prediction in intelligent transportation systems: coupling unsupervised and supervised learning techniques. 2019 International Conference on Control, Automation and Diagnosis (ICCAD). 1–6 (2019).
- [33] Musa A. B. A comparison of  $\ell_1$ -regularization, PCA, KPCA and ICA for dimensionality reduction in logistic regression. *International Journal of Machine Learning and Cybernetics*. **5**, 861–873 (2014).
- [34] Zhang C., Ma Y. *Ensemble Machine Learning: Methods and Applications*. Springer, New York (2012).
- [35] Huotari M., Arora S., Malhi A., Främling K. Comparing seven methods for state-of-health time series prediction for the lithium-ion battery packs of forklifts. *Applied Soft Computing*. **111**, 107670 (2021).
- [36] He X., Zhao K., Chu X. AutoML: A survey of the state-of-the-art. *Knowledge-Based Systems*. **212**, 106622 (2021).
- [37] Goebel K., Saha B., Saxena A., Celaya J. R., Christophersen J. P. Prognostics in battery health management. *IEEE Instrumentation & Measurement Magazine*. **11** (4), 33–40 (2008).
- [38] Mishra M., Martinsson J., Rantatalo M., Goebel K. Bayesian hierarchical model-based prognostics for lithium-ion batteries. *Reliability Engineering & System Safety*. **172**, 25–35 (2018).
- [39] Qu J., Liu F., Ma Y., Fan J. A Neural-Network-Based Method for RUL Prediction and SOH Monitoring of Lithium-Ion Battery. *IEEE Access*. **7**, 87178–87191 (2019).
- [40] Wang C., Lu N., Wang S., Cheng Y., Jiang B. Dynamic long short-term memory neural-network-based indirect remaining-useful-life prognosis for satellite Lithium-ion battery. *Applied Sciences*. **8** (11), 2078 (2018).
- [41] Chung J., Gulcehre C., Cho K., Bengio Y. Empirical Evaluation of Gated Recurrent Neural Networks on Sequence Modeling. Preprint arXiv:1412.3555 (2014).
- [42] Siami-Namini S., Tavakoli N., Namin A. S. The Performance of LSTM and BiLSTM in Forecasting Time Series. 2019 IEEE International Conference on Big Data (Big Data). 3285–3292 (2019).
- [43] Hochreiter S., Schmidhuber J. Long Short-Term Memory. *Neural Computation*. **9** (8), 1735–1780 (1997).
- [44] Prajapati A., Bechtel J., Ganesan S. Condition based maintenance: A survey. *Journal of Quality in Maintenance Engineering*. **18** (4), 384–400 (2012).

- [45] Ait Lhadj Lamin S., Raghib A., Abou El Majd B. Robust multi-objective optimization for solving the RFID network planning problem. *Mathematical Modeling and Computing*. **8** (4), 616–626 (2021).
- [46] Chemlal Y., Azouazi M. Implementing quality assurance practices in teaching machine learning in higher education. *Mathematical Modeling and Computing*. **10** (3), 660–667 (2023).
- [47] Jin H., Song Q., Hu X. Auto-Keras: An efficient neural architecture search system. *KDD '19: Proceedings of the 25th ACM SIGKDD International Conference on Knowledge Discovery & Data Mining*. 1946–1956 (2019).

## Загальна модель інформації та ланцюга прийняття рішень з використанням допомоги на основі машинного навчання у виробничому контексті

Маллук І.<sup>1,2</sup>, Абу Ель Мажд Б.<sup>2</sup>, Саллез Ю.<sup>1</sup>

<sup>1</sup>Політехнічний університет Верхньої Франції – LAMIH UMR CNRS n° 8201 F-59313 Валансьєн, Франція  
<sup>2</sup>LMSA, FSR, Університет Мухаммеда V у Рабаті, Марокко

У наш час виробники повинні мати справу з величезною міжнародною конкуренцією і постійно вдосконалювати свої показники. У цьому контексті для виробничих систем використовуються декілька основних підходів, а саме: CBM (обслуговування на основі стану), PHM (прогнозування та керування станом) і PLM (керування життєвим циклом продукції) для підтримки і підвищення їхньої доступності, надійності і продуктивності. Це означає, що дані про експлуатаційне використання виробничого обладнання повинні бути доступними для всіх зацікавлених сторін через ефективні інформаційні ланцюги. Однак, незважаючи на велику кількість даних, зацікавлені сторони повинні отримувати допомогу в прийнятті рішень. Ця стаття має на меті запропонувати загальну архітектуру, яка моделює ланцюжок інформації та рішень від цільової системи до відповідних зацікавлених сторін, допомагаючи їм у прийнятті рішень. Запропонована загальна архітектура проілюстрована прикладом використання на основі алгоритму LSTM (Long Short-Term Memory) в контексті керування енергоспоживанням для парку мобільних роботів.

**Ключові слова:** виробництво; прийняття рішень; прогнозування та керування здоров'ям (PHM), довга короткочасна пам'ять. (LSTM)