МЕТОДИ ТА СИСТЕМИ ОПТИКО-ЕЛЕКТРОННОЇ І ЦИФРОВОЇ ОБРОБКИ ЗОБРАЖЕНЬ ТА СИГНАЛІВ

УДК 004.31

V.M. BOROVYTSKY, I.I. AVDIEIONOK, S.E. TUZHANSKYI, H.L. LYSENKO

PHOTONIC INTEGRATED CIRCUITS FOR OPTICAL MATRIX- VECTOR MULTIPLICATION

*National Technical University of Ukraine “Igor Sikorsky Kyiv Polytechnic Institute”,
37, Prosp. Peremohy, Kyiv, Ukraine, 03056, e-mail: vborovytsky@yahoo.com
Vinnytsia National Technical University, Khmelnytske shose, 95, 21021, Vinnytsia, Ukraine*

Анотація. У статті запропонована класифікація фотонних інтегральних схем (ФІС) для оптичного перемноження векторів на матриці. Згідно неї ФІС можуть бути розділені на дві групи. Перша група об'єднує багатошарові фотонні інтегральні схеми, у яких активні елементи, що виконують множення розташовані в одному шарі, а оптичні хвилеводи для подачі вхідних та вихідних сигналів - у інших шарах. Друга група охоплює планарні ФІС, у яких активні елементи розміщені у одному шарі разом з оптичними хвилеводами. Розглянуто побудову, принципи функціонування ФІС обох груп та здійснено аналіз їх переваг та недоліків.

Ключові слова: фотонна інтегральна схема, перемноження вектору на матрицю, оптичний хвилевод, мікро-кільцевий резонатор, інтерферометр Мах-Зандера.

Abstract. The article proposes a classification of photonic integrated circuits (PICs) for optical multiplication of vectors on matrices. According to this classification, such PIC can be divided into two groups. The first group combines multilayer photonic integrated circuits, in which active elements that perform multiplication are located in one layer, and optical waveguides for input and output signals are located in other layers. The second group covers planar PIC, in which active elements are placed in one layer together with optical waveguides. The article describes the construction, principles of operation of FIS of both groups and contains an analysis of their advantages and disadvantages.

Key words: photonic integrated circuit, multiplication of vector by matrix, optical waveguide, micro-ring resonator, Mach-Zehnder interferometer.

DOI: 10.31649/1681-7893-2022-43-1-11-18

INTRODUCTION

Matrix-vector multiplication (MVM) is a key operation in artificial neural networks, integral transform and signal filtration [1-3]. In many cases it is applied software realization of MVM using personal and embedded computers. Sequential execution of processor command cannot reach high speed MVM. That is why it is widely used vector and tensor processors, multi core processor, multi core digital signal processor and multi core graphical processor for acceleration of MVM [4, 5, 6]. Nevertheless, such processors have disadvantages like limited speed of MVM, high price and large power consumption. They make difficult application of these processors in system, where high-speed signal processing and fast neural networks are necessary.

On the other side optical MVM techniques can realize high speed signal processing and fast neural networks. The most interesting MVM realization is one layer or multi-layer photonic integrated circuits (PIC) that combine high productivity of MVM calculations with small dimensions and relatively small power consumption. It makes optical MVM PIC one of perspective alternatives to multi core processors. Unfortunately, absence of classification of such PIC. The goal of this work is to propose classification that covers all principal groups of MVM PIC.

1. MULTILAYER PHOTONIC INTEGRATED CIRCUITS FOR MVM

We propose to divide all MVM PIC into two groups. The first group contains PIC in which active elements that play the main role in MVM are placed between the layers of input and output optical waveguides. The second one joins PICs in which active elements are placed in the plane of optical waveguides. The typical PIC of the first group is the optical processor EnLight256 (Fig. 1) [7].

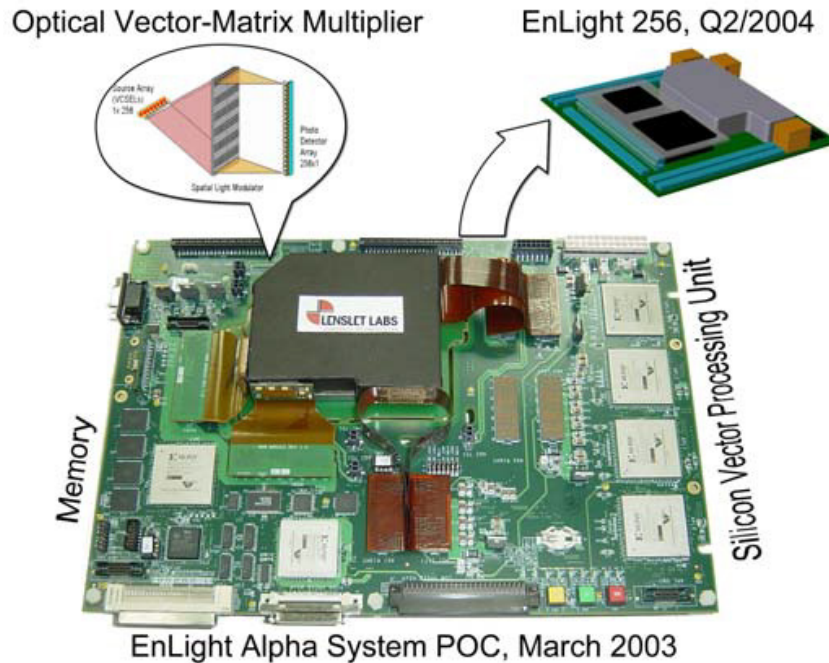

Figure 1 - Optical processor EnLight256 [7]

It has 256 analog electrical inputs and 256 analog output lines, but MVM is done optically. As a result, it multiplies a vector of 256 elements by a matrix of 256×256 in one step lasting 8 ns. This PIC has 256 laser sources modulated by the electrical inputs, the 256×256 matrix of liquid crystal spatial light modulators that specify the matrix coefficients and 256 photodetectors with micro lenses and the read out circuit for generation of the output electrical signals. In this PIC the role of active elements plays the liquid crystal cells that change its transmission coefficients according to matrix coefficients. It was the first serially manufactured MVM PIC but it hasn't get wide application. The advantage of EnLight256 is very fast MVM made in fully parallel mode. The disadvantage is high price, high complexity and limited accuracy of analog MVM. The matrix of liquid crystal spatial light modulators is the most expensive part of this PIC that reduces wide implementation of EnLight256 [8]. The other known design of optical MVM is based on a matrix of laser diodes with resonators, matrices of photodetectors integrated with an ADC, matrices of specialized masks of diffraction structures and a digital control device [9]. The input signal is formed by the control laser diodes that form the prime matrix and the vector. The result is read from photo receivers. Diffraction elements are used as an array of optical masks. As a result of the interference, the result of calculations of digit partial sums, transfers and multiplication results is formed. Due to the digital representation of values at the input of the system, an increase in processing time and some complication of post-processing of the result, the accuracy of calculations can be increased, the combination with digital electronic devices can be simplified, and it also makes it possible to process variable numbers. The result is read from the radiation intensity indicator. In this MVM the role of active elements plays the masks of diffraction structures that separate the input optical systems to the matrices of photodetectors according to matrix coefficients.

The interesting approach for optical MVM is application a combination of multiple diffraction elements with mirrors for reduction of PIC size [10] [11]. It consists of several amplitude- and phase-encoded planes and mirrors, which are necessary to change the direction of light propagation to reduce the volume of the system. First, the parameters of these planes are adjusted to change the amplitude and phase of the beam. The beam

diffracts in free space and then falls on the first plane, then diffracts in free space and falls on the plane, and so on. The final optical field is formed after the beam passes through all the planes, after which they are detected by the photodetector array. Formally, diffraction elements can provide optical MVM but, in reality, they are very sensitive to location relatively optical waveguides, to wavelength variations and they require some free space for propagation and diffraction of optical beams. That is why multilayer PIC with diffraction elements have not wide implementation.

The patent [13] proposes the following architecture for general-purpose matrix analog microprocessors and matrix memory for data processing based on optical MVM. The PIC includes a three-dimensional memory with read/write access to fragments containing a plurality of cells. Each fragment stores a matrix of data. Each memory cell has a photochrome that fluoresces under the influence of illumination, emitted by a light source, and a photo resistive element whose resistance depends on photochromic illumination. In this design the active elements are photochrome cells. The optical flux of these cells defines the matrix coefficients in this MVM PIC. This design is economical due to simple manufacture process, but it has low accuracy due to sufficient variation of amplitude of photochromic illumination and illumination of fluorescent material.

The authors suppose that the most perspective are multilayer PICs with matrices of modern electro chrome films [14] [15]. These thin films can change their transparence proportionally applied voltage and they can save their stage without electrical supply. It makes these films good material for active elements in MVM PICs. Technology of production of electro chrome films on glass is widely used for serial smart window manufacture [14] [15]. The advantages of such PIC are fast MVM, simple manufacture process and low price. The disadvantage is the small accuracy of analog MVM results, but it could be good enough for many applications in hardware realization of artificial neural networks and units for digital image processing.

2. PLANAR PHOTONIC INTEGRATED CICRUIITS FOR MVM

In this group MVM PICs have active elements placed in the plane of optical waveguides. The typical PICs of this group are ones with matrices of micro-ring resonators (MRRs) [16] [17]. They use wavelength division multiplexing (WDM) method for MVM - WDM-MVM (Figure 2). The input optical signals come to the MRR front module which works as narrow spectral filters, and it plays a role of MVM active element. This module forms one optical signal in one optical waveguide the collects optical signals with different wavelengths and the amplitudes corresponded to ones of the input signals. Other words, the unit performs modulation and multiplexing of input optical signal. Then one multiplexed signal is divided, and it comes to the next unit – a MRR matrix core. For given wavelengths these MMRs can change transmittance of optical signals according to corresponding matrix coefficients. This unit forms a set of output optical signals, each output signal has a definite wavelength, and its amplitude is proportional to multiplication of input signal amplitudes (vector) to matrix row coefficients defined by the transmittance for MRRs. Spectral transmittance can be changed by variation of optical path length in MMR, for example by changing refractive index or temperature. The PICs with MRRs have very interesting topology and they are supposed as one of the best solution for optical MVM [16] - [19].

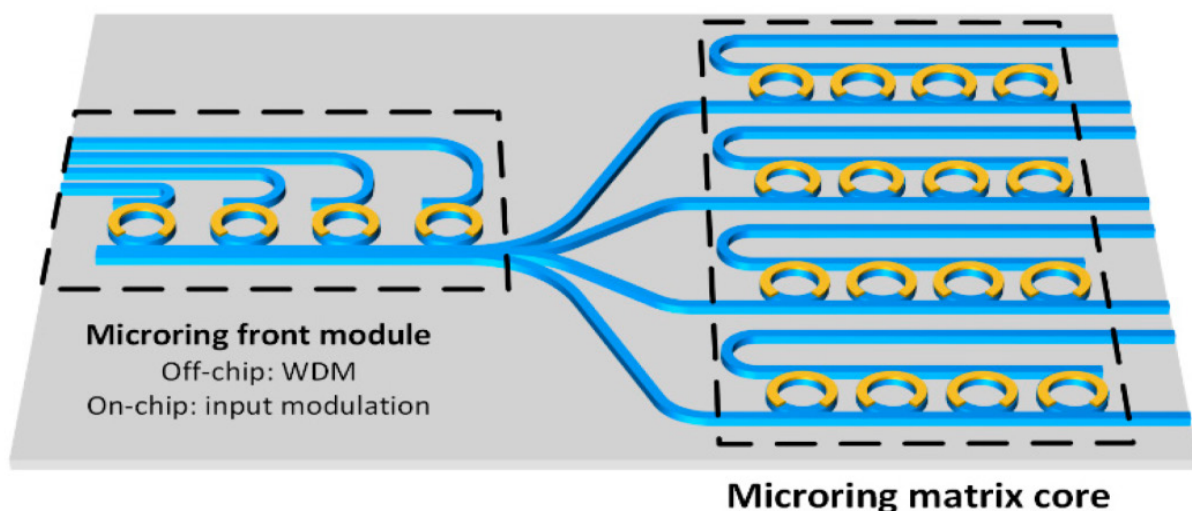

Figure 2 – The scheme of WDM-MVM

The other PIC design applies the generator of the optical input signals made by a set of laser sources with different wavelengths, a WDM unit that multiplexes and divides laser radiation to form several optical signals with different waves. Then these signals pass through multi-channel modulator and come to MMR matrix core, where MRR transmittances are proportional to matrix coefficients [18]. The advantage of PICs with MRRs is the ability to perform parallel MVM or even matrix to matrix multiplication. But these PICs have sophisticated topology, sensitivity to any wavelength variation, complexity of the device for changing MMR transmittance and in some cases they require laser sources with many different wavelengths. As a result, they have high prices, and high sensitivity to temperature variation. Nevertheless, such PIC are considered as most perspective planar device for optical MVM.

The planar MVM PIC with a matrix of light modulator is described in the patent [20]. Each light modulator changes the transmittance according to matrix coefficients. It is proposed to use electro-optical, acousto-optical or thermos-optical modulators. This PIC has a simple and economical planar design. It performs analog MVM that reduces MVM accuracy.

The alternative approach is application of Mach–Zehnder interferometer (MZI) method for MVM (MZI-MVM) (Fig. 3) [21]-[25]. These PICs have two-dimensional periodical structure with miniature MZIs in its nodes. Each MZI has two interference arms in the form of optical waveguides but in one arm it is present phase-shifted device. In most cases, this device is an optically active element that changes its refractive index depending on applied voltage. Thus, MZI becomes MVM active element. As a result, this unit introduces a definite phase shift in one interference arms, and it changes the transparent coefficient of miniature MZI. The matrices of MZI makes possible realization of analog or digital multiplication [21]-[24]. In some PIC diffractive optical elements may be used in combination with MZI to perform sequential MVMs necessary for realization of multi-layer neural networks [25]. In other PICs a combination of MRRs and MZI is used to perform fast MVM [19].

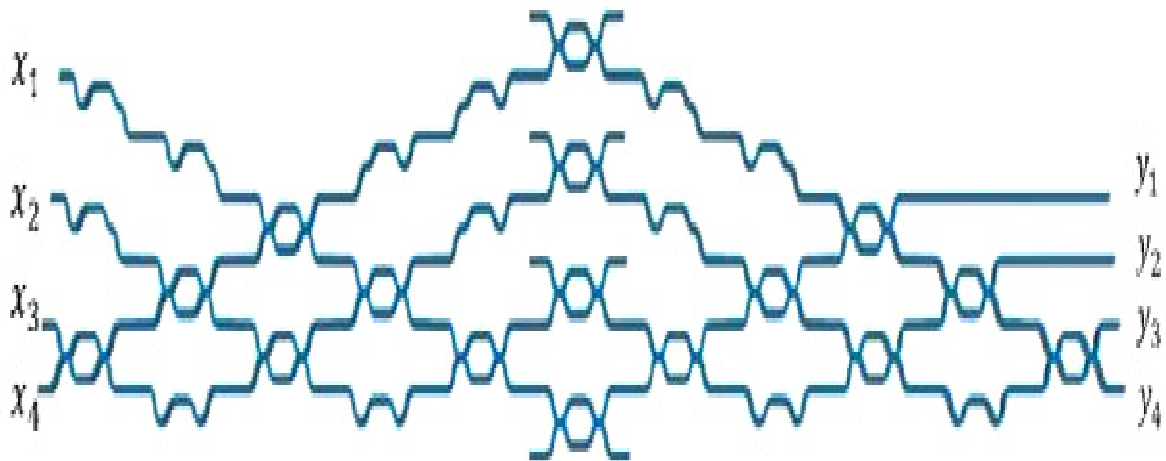

Figure 3 – MZI-MVM method

PICs with numerous MZI are widely used in optical communication systems. Like PICs with MRRs these PICs have high price and high sensitivity to temperature variation. In the case of digital MVM when each input vector element is presented by 8 – 32 binary optical inputs the MZI combination becomes extremely sophisticated. The complexity of PIC design and high price would limit wide application of PIC with big number of MZI.

Micro-electrical-mechanical systems (MEMS) like moving micro apertures, moving optical waveguide, or rotating or rotating micro mirrors could potentially be used in both MVM PIC groups as active elements for light modulation (Fig. 4) [26]. But complexity of production, high price and limited working time make difficult MEMS application in MVM PICs.

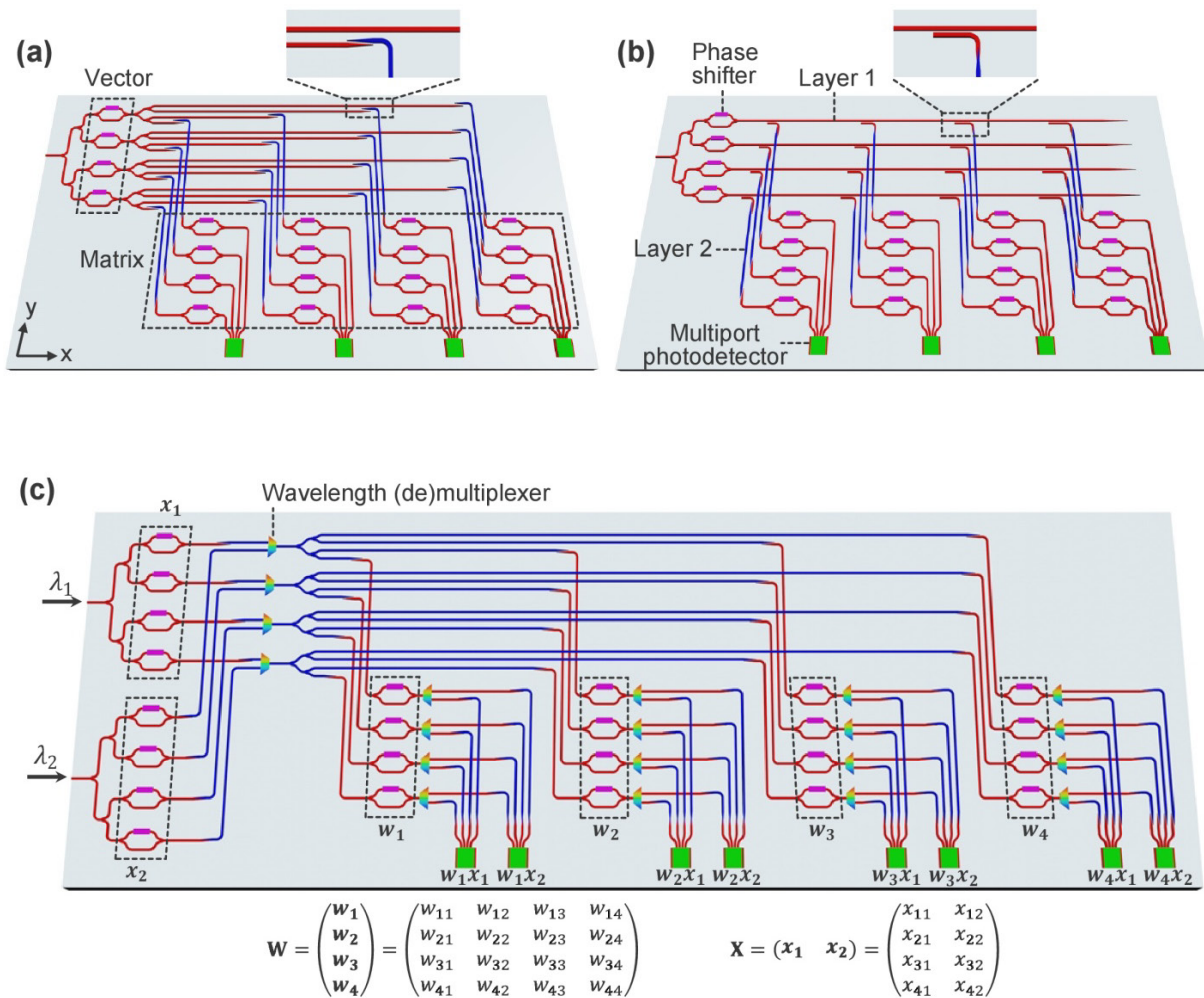

Figure 4 – Integrated photonic architectures for matrix-vector multiplication (MVM) (a,b).
The architecture for general matrix-matrix multiplication (GEMM)(c) [26]

CONCLUSIONS

1. It is proposed the classification of MVM PICs on two groups. The first group contains PIC in which active elements that play the main role in MVM are placed between the layers of input and output optical waveguides. The second group includes PICs that have active elements placed in the plane of optical waveguides.

2. The biggest number of PIC performs analog MVM. In this case the MVM results is sensitive to variance of optical properties of active elements like liquid crystal cells, photochrome cells, MMRs etc. But fast MVM, compact and economical design and in some cases low power consumption open wide perspectives for MVM PIC application in sensors, robotics, drone controls and smart devices.

3. The authors suppose that the most perspective are multilayer MVM PICs with matrices of modern electro chrome films. The advantage of such PIC is fast MVM and low price due to simple and economical manufacture process. The disadvantage is the small accuracy of analog MVM results, but it could be good enough for many applications in hardware realization of artificial neural networks and units for digital image processing.

МЕТОДИ ТА СИСТЕМИ ОПТИКО-ЕЛЕКТРОННОЇ І ЦИФРОВОЇ ОБРОБКИ ЗОБРАЖЕНЬ ТА СИГНАЛІВ

СПИСОК ЛІТЕРАТУРИ

1. Н. Б. Шаховська, Р. М. Камінський, О. Б. Вовк, Системи штучного інтелекту. Львів: Видавництво Львівської політехніки, 2018. 392 с.
2. B. Patra, An Introduction to Integral Transforms, CRC Press, 2018, 428 p.
3. S. W. Smith, The Scientist and Engineer's Guide to Digital Signal Processing, The Scientist and Engineer's. California Technical Publishing, 1999, 688 p.
4. N. N. Sirhan, S. I. Serhan, "Multi-core processors: concepts and implementation," *Int. Journal of Computer Science & Information Technology*, Vol 10, No 1, 2018, p. 1 – 10. doi.org/10.5121/ijcsit.2018.10101
5. D. Zhong, Q. Cao, G. Bosilca, J. Dongarra, "Using Advanced Vector Extensions AVX-512 for MPI Reductions," *Proc. EuroMPI/USA - 2020*, September 21–24, 2020.
6. NVIDIA A100 Tensor Core GPU Architecture, Product information, NVIDIA Corporation. 2020, 82 p.
7. H. Pituach, G. Haplada, "EnLight256 8000 Giga MAC/sec fixed point DSP," Product information, Lenslet Ltd , 2003.
8. J. Barhen *et al.*, "High performance FFT on multicore processors", *Proceedings of the Fifth International Conference on Cognitive Radio Oriented Wireless Networks and Communications*, 2010, pp. 1-6, doi: 10.4108/ICST.CROWCOM2010.9283.
9. Г. Л. Лисенко, С. Є. Тужанський and М. М. А. Альравашді, "Оптоелектронний суматор помножувач для реалізації алгоритму ДМАС", *Опт-ел. інф-енерг. техн.*, вип. 2(32), 2017, с. 43–56.
10. Г. Л. Лысенко, С. Е. Тужанский, М. Альравшдех, "Фотонные логические элементы на основе фазово-синхронизированных массивов СС-VCSEL", *Опт-ел. инф-енерг. техн.*, вип. 2(26). 2013. С. 42-47.
11. R. Tang, T. Tanemura and Y. Nakano, "Integrated reconfigurable unitary optical mode converter using MMI couplers", *IEEE Photonics Technol. Lett.* 29, 971–974, 2017.
12. G. Jochen, L. G. Dr., R. H. Dr. and S. Wolfgang, "Verfahren sowie Vorrichtung zur Entzerrung von optisch übertragenen Daten". Patent DE 10 2005 047 550 A1 2007.04.05, 2007.
13. H. Nejad and M. Seyyedy, "Columnar1t-nmemory cell structure and its method of formation and operation". Patent US 2005/0162883 A1, 2005.
14. N. G. Park, B. W. Kim a, A. Poquet, G. Campet, and et. "A new simple method for manufacturing electrochromic tungsten oxide films," *Active and Passive Elec. Comp.*, 1998, Vol. 20, pp. 125-133.
15. M. P. Browne, H. Nolan, N. C. Berner, G. S. Duesberg and et. "Electrochromic Nickel Oxide Films for Smart Window Applications," *Int. J. Electrochem. Sci.*, No. 11, 2016, p. 6636–6647, doi.org/10.20964/2016.08.38
16. V. A. Pilipovich, A. K. Esman, I. A. Goncharenko and V. K. Kuleshov, "An optical matrix multiplier", doi.org/10.1364/JOT.73.000834.
17. L. Yang, R. Ji, L. Zhang, J. Ding, and Q. Xu, "On-chip CMOS-compatible optical signal processor," *Optic Express*, Vol. 20, No. 12, 2012, p.13560 - 13565.
18. A. N. Tait, T. F. de Lima, M. A. Nahmias, B. J. Shastri and P. R. Prucnal, "Reconfigurable analog photonic networks," *2017 IEEE Photonics Conference (IPC)*, 2017, pp. 267-268, doi: 10.1109/IPCon.2017.8116099.
19. T. F. d. Lima, B. J. Shastri, A. N. Tait and M. A. Nahmias, "Progress in neuromorphic photonics," *Nanophotonics*, Vo.1, No.39, 2016. doi.org/10.1515/nanoph-2016-0139.
20. H. Seyringer, Heinz, S. Höchst, J. Lindau, Optischer Matrix-Vektor Multiplizierer, Patent DE 10 2004 014 658 A1 2005.10.13.
21. V. Bangari, B. A. Marquez, H. Miller, A. N. Tait, and et. Digital Electronics and Analog Photonics for Convolutional Neural Networks (DEAP-CNNs), doi.org/10.1109/JSTQE.2019.2945540, 2019 October.
22. J. J. Carolan, M. Prabhu, S. A. Skirlo, Y. Shen, and et., "Apparatus and methods for optical neural network". Patent US 11,334,107 B2, 2022.
23. Y. Shen, L. Jing, R. Dangovski, P. Xie, and et., "Optoelectronic computing system". Patent US 2020/0250534 A1, 2020.
24. H. Zhou, J. Dong, J. Cheng, W. Dong, and et. "Photonic matrix multiplication lights up photonic accelerator and beyond", *Light: Science & Applications*, 2022. doi.org/10.1038/s41377-022-00717-8.
25. H. H. Zhu, J. Zou, H. Zhang, Y. Z. Shi and et., "Space-efficient optical computing with an integrated chip diffractive neural network," *Nature Communications*, 13:1044, 2022, p.1-9. doi.org/10.1038/s41467-022-28702-0
26. Rui Tang, Makoto Okano, Kasidit Toprasertpong, Shinichi Takagi, Dirk Englund, and Mitsuru Takenaka, "Two-layer integrated photonic architectures with multipoint photodetectors for high-fidelity and energy-efficient matrix multiplications," *Opt. Express* 30, 33940-33954 (2022) doi.org/10.1364/OE.457258

REFERENCES

1. N. B. Shakhovska, R. M. Kaminsky, O. B. Vovk, Systems of artificial intelligence. Lviv: Publishing House of Lviv Polytechnic, 2018. 392 p.
2. B. Patra, An Introduction to Integral Transforms, CRC Press, 2018, 428 p.
3. S. W. Smith, The Scientist and Engineer's Guide to Digital Signal Processing, The Scientist and Engineer's. California Technical Publishing, 1999, 688 p.
4. N. N. Sirhan, S. I. Serhan, "Multi-core processors: concepts and implementation," *Int. Journal of Computer Science & Information Technology*, Vol 10, No 1, 2018, p. 1 – 10. doi.org/10.5121/ijcsit.2018.10101
5. D. Zhong, Q. Cao, G. Bosilca, J. Dongarra, "Using Advanced Vector Extensions AVX-512 for MPI Reductions," *Proc. EuroMPI/USA - 2020*, September 21–24, 2020.
6. NVIDIA A100 Tensor Core GPU Architecture, Product information, NVIDIA Corporation. 2020, 82 p.
7. H. Pituach, G. Haplada, "EnLight256 8000 Giga MAC/sec fixed point DSP," Product information, Lenslet Ltd , 2003.
8. J. Barhen et al., "High performance FFT on multicore processors", Proceedings of the Fifth International Conference on Cognitive Radio Oriented Wireless Networks and Communications, 2010, pp. 1-6, doi: 10.4108/ICST.CROWNCOM2010.9283.
9. G. L. Lysenko, S. E. Tuzhanskyi and M. M. A. Alravashdi, "Optoelectronic adder and multiplier for implementation of the DMAC algorithm", *Optic-Electronic Infor.-Energy Techn.*, Vol. 2(32), 2017, p. 43–56.
10. G. L. Lysenko, S. E. Tuzhansky, M. Alravshdeh, "Photonic logic elements based on phase-synchronized SS-VCSEL arrays", *Optic-Electronic Information-Energy Technologies*, Vol. 2(26). 2013. P. 42-47.
11. R. Tang, T. Tanemura and Y. Nakano, "Integrated reconfigurable unitary optical mode converter using MMI couplers", *IEEE Photonics Technol. Lett.* 29, 971–974, 2017.
12. G. Jochen, L. G. Dr., R. H. Dr. and S. Wolfgang, "Verfahren sowie Vorrichtung zur Entzerrung von optisch übertragenen Daten". Patent DE 10 2005 047 550 A1 2007.04.05, 2007.
13. H. Nejad and M. Seyyedy, "Columnar1t-nmemory cell structure and its method of formation and operation". Patent US 2005/0162883 A1, 2005.
14. N. G. Park, B. W. Kim a, A. Poquet, G. Campet, and et. "A new simple method for manufacturing electrochromic tungsten oxide films," *Active and Passive Elec. Comp.*, 1998, Vol. 20, pp. 125-133.
15. M. P. Browne, H. Nolan, N. C. Berner, G. S. Duesberg and et. "Electrochromic Nickel Oxide Films for Smart Window Applications," *Int. J. Electrochem. Sci.*, No. 11, 2016, p. 6636–6647, doi.org/10.20964/2016.08.38
16. V. A. Pilipovich, A. K. Esman, I. A. Goncharenko and V. K. Kuleshov, "An optical matrix multiplier", doi.org/10.1364/JOT.73.000834.
17. L. Yang, R. Ji, L. Zhang, J. Ding, and Q. Xu, "On-chip CMOS-compatible optical signal processor," *Optic Express*, Vol. 20, No. 12, 2012, p.13560 - 13565.
18. A. N. Tait, T. F. de Lima, M. A. Nahmias, B. J. Shastri and P. R. Prucnal, "Reconfigurable analog photonic networks," *2017 IEEE Photonics Conference (IPC)*, 2017, pp. 267-268, doi: 10.1109/IPCon.2017.8116099.
19. T. F. d. Lima, B. J. Shastri, A. N. Tait and M. A. Nahmias, "Progress in neuromorphic photonics," *Nanophotonics*, Vo.1, No.39, 2016. doi.org/10.1515/nanoph-2016-0139.
20. H. Seyringer, Heinz, S. Höchst, J. Lindau, Optischer Matrix-Vektor Multiplizierer, Patent DE 10 2004 014 658 A1 2005.10.13.
21. V. Bangari, B. A. Marquez, H. Miller, A. N. Tait, and et. Digital Electronics and Analog Photonics for Convolutional Neural Networks (DEAP-CNNs), doi.org/10.1109/JSTQE.2019.2945540, 2019 October.
22. J. J. Carolan, M. Prabhu, S. A. Skirlo, Y. Shen, and et., "Apparatus and methods for optical neural network". Patent US 11,334,107 B2, 2022.
23. Y. Shen, L. Jing, R. Dangovski, P. Xie, and et., "Optoelectronic computing system". Patent US 2020/0250534 A1, 2020.
24. H. Zhou, J. Dong, J. Cheng, W. Dong, and et. "Photonic matrix multiplication lights up photonic accelerator and beyond", *Light: Science & Applications*, 2022. doi.org/10.1038/s41377-022-00717-8.
25. H. H. Zhu, J. Zou, H. Zhang, Y. Z. Shi and et., "Space-efficient optical computing with an integrated chip diffractive neural network," *Nature Communications*, 13:1044, 2022, p.1-9. doi.org/10.1038/s41467-022-28702-0
26. Rui Tang, Makoto Okano, Kasidit Toprasertpong, Shinichi Takagi, Dirk Englund, and Mitsuru Takenaka, "Two-layer integrated photonic architectures with multiport photodetectors for high-fidelity and energy-efficient matrix multiplications," *Opt. Express* 30, 33940-33954 (2022) doi.org/10.1364/OE.457258

Надійшла до редакції 25.03.2022р.

МЕТОДИ ТА СИСТЕМИ ОПТИКО-ЕЛЕКТРОННОЇ І ЦИФРОВОЇ ОБРОБКИ ЗОБРАЖЕНЬ ТА СИГНАЛІВ

BOROVYTSKY VOLODYMYR – Doctor of Technical Sciences, Professor of the Department of Computer-Integrated Optical and Navigation Systems, National Technical University of Ukraine “Igor Sikorsky Kyiv Polytechnic Institute”, Kyiv, *e-mail: vborovytsky@yahoo.com*

AVDIEIONOK IRYNA – PhD student of the Department of Computer-Integrated Optical and Navigation Systems, National Technical University of Ukraine “Igor Sikorsky Kyiv Polytechnic Institute”, Kyiv, *e-mail: avdeionok.ira@gmail.com*

TUZHANSKYI STANISLAV – Ph.D., Associate Professor of the Department of Biomedical Engineering and Optoelectronic Systems, Vinnytsia National Technical University, Vinnytsia, *e-mail: slavat@vntu.edu.ua*

LYSENKO HENNADIЙ – Ph.D., Professor of the Department of Biomedical Engineering and Optoelectronic Systems, Vinnytsia National Technical University, Vinnytsia, *e-mail: lgl@vntu.edu.ua*