

CONCLUSIONS

1. Technology of repair welding of standard heat-resistant steel 12Kh1MF being widely used in manufacture of the boiler units of HEPS and HPP was developed and its weldability was investigated.

2. Preliminary and concurrent heating together with postweld low-temperature recovery can be used for repair of damaged assemblies and parts of the boiler units from heat-resistant steels in acting HEPS and HPP in the case when performance of high-temperature tempering is impossible. Further running at operating temperature 545 °C promotes reduction of the residual welding stresses (up to the level of around 150 MPa) that allows extending resource of the repaired boiler unit for limited period up to the next examination.

1. Khromchenko, F.A. (2002) *Service life of welded joints of steam pipelines*. Moscow: Mashinostroenie.
2. Melekhov, R.K., Pokhmursky, V.I. (2003) *Structural materials of power equipment*. Kiev: Naukova Dumka.
3. Anokhov, A.E., Korolkov, P.M. (2003) *Welding and heat treatment of case power equipment in repair*. Kiev: Ekotekhnologiya.
4. Anokhov, A.E., Khromchenko, F.A., Fedina, I.V. (1986) New technology of repair welding of chrome-molybdenum steel parts without heat treatment. *Scarochn. Proizvodstvo*, **10**, 15–17.
5. Makarov, E.L. (1981) *Cold cracks in welding of alloy steels*. Moscow: Mashinostroenie.
6. Shorshorov, M.Kh., Chernyshova, T.A., Krasovsky, A.I. (1972) *Weldability tests of metals*. Moscow: Metallurgiya.
7. Shorshorov, M.Kh., Belov, V.V. (1972) *Phase transformations and changes of steel properties in welding*. Moscow: Nauka.
8. Khromchenko, F.A. (2005) *Welding technology in repair works*. Moscow: Internet Engineering.
9. *RD 108.021.112–88*: Repair of defects in cast case parts of turbines and fittings by welding-up methods without heat treatment. Moscow.
10. Anokhov, A.E., Ganiev, F.B., Korolkov, P.M. (2003) Improvement of technology of repair welding and heat treatment is the base of service life prolongation of vapor turbines. *Montazhn. i Spets. Raboty v Stroitelstve*, **7**, 7–11.
11. Anokhov, A.E., Korolkov, P.M. (2006) *Welding and heat treatment in power engineering*. Kiev: Ekotekhnologiya.
12. Tsaryuk, A.K., Ivanenko, V.D., Volkov, V.V. et al. (2009) Repair welding of turbine case parts from heat-resistant steels without subsequent heat treatment. *The Paton Welding J.*, **12**, 32–36.
13. Kasatkin, B.S., Brednev, V.I., Volkov, V.V. (1981) Procedure of examination of deformation kinetics at delayer fracture. *Avtomatich. Svarka*, **11**, 13.
14. Kozlov, R.A. (1969) *Hydrogen in welding of hull steels*. Leningrad: Sudostroenie.
15. Kozlov, R.A. (1986) *Welding of heat-resistant steels*. Leningrad: Mashinostroenie.
16. Demyantsevich, S.V., Zemzin, V.N. (1979) Procedure of evaluation of welded joint susceptibility to cracking in heat treatment. *Trudy TsKTI*, **169**, 22–27.
17. *RTM-1s–89 (RD 34 15.027–89)*: Welding, heat treatment and testing of pipe systems of boilers and pipelines in mounting and repair of power plant equipment. Moscow: Energoizdat.

MODERN METHODS OF SURFACING THE TOOLS OF AGRICULTURAL TILLERS AND HARVESTERS (Review)

V.S. SENCHISHIN and Ch.V. PULKA

Ternopol I. Puluj National Technical University, Ternopol, Ukraine

It is shown that application of induction surfacing is the most promising for flat parts of agricultural machinery with wall (BM) thickness of 2.0–6.0 mm and deposited metal (DM) thickness of 0.8–2.0 mm. In this case, minimum mixing of BM and DM, minimum equipment cost, possibility of mechanization and automation are provided.

Keywords: *surfacing processes, electric contact strengthening, agricultural machinery tools, thin parts, induction surfacing, automation*

Thin flat parts are widely applied in agriculture as tools of tilling and harvesting machinery, namely: plough shares, cultivator hoes, skim plough discs, shredder knives, etc. which operate under the conditions of abrasive wear and considerable static and dynamic loads. These parts should

have high strength and wear resistance [1–4]. However, during operation the metal continuously contacts the soil and plants that, in its turn, leads to blade blunting. To ensure the cutting properties, the tools should sharpen themselves during operation. Bimetal (two-layer) working parts are the most suitable for these conditions. Their strength is ensured by base material from which the tool is made, and wear resistance and self-sharpening are provided by

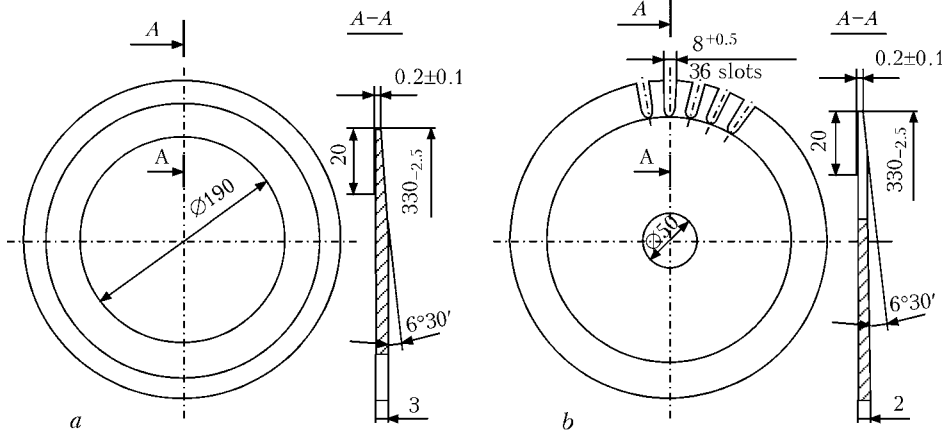

Figure 1. Schematic of disc cutter design [12]: *a* – nondriven; *b* – driven

the cladding layer deposited on the base metal. Self-sharpening depends on the ratio of thickness and wear resistance of base and cladding layers [5]:

$$\omega = \frac{\varepsilon_2 h_2}{\varepsilon_1 h_1},$$

where ε_1 , ε_2 is the resistance of base and cladding layers, respectively; h_1 , h_2 is the thickness of the base and cladding layers, respectively.

The best self-sharpening is provided at $\omega = 1.5$.

Various surfacing processes are applied for tool strengthening, namely: electric contact, plasma, electric arc, explosion cladding, induction and other strengthening techniques [4, 6–11].

Known is a method of surfacing agricultural machinery tools, using electric contact strengthening [4, 6 12, 13]. With this method the filler material can be powders, wires and strips. The principle of the technology is application on the part surface of a powder-like wear-resistant hard material (charge), strip and wire with their sub-

sequent heating up to the temperature, at which their sintering and formation of a strong diffusion bond with the part take place. This technology is applied at strengthening of tiller disc cutters, which should have a wear-resistant cutting edge and should sharpen themselves in operation.

Figure 1 shows disc knives, surfaced by powder-like hard alloy by electric contact method, and Figure 2 shows a machine for strip welding to skim plough disc [1, 12].

In [13] a technological process of electric contact surfacing of a share by flux-cored wire of segmented cross-section is proposed. In this case, the process of flux-cored wire surfacing runs in two stages: cold compacting of the powder core and, as a consequence, deformation of filler materials in the zone of contact with the part; surfacing process proper, which provides heating of flux-cored wire at the segment top, in the zone of intensive heat evolution, deformation propagation to peripheral zones, melting and welding of the shell to the base with simultaneous sintering of the powder core. Figure 3 shows a share surfaced by the above technology.

Advantages of this process are absence of base metal penetration, minimum deformations of surfaced parts, ability to deposit thin layers, high heating rate, which may reach several thousand degrees per second. A disadvantage is a low efficiency of the process, absence of batch-production of the equipment, and non-uniform quality of the deposited metal, as well as complexity of manufacturing flux-cored wire of segment section.



Figure 2. General view of machine for strip welding to skim plough disc based on up-graded MShPR-300/1200 machine [1]

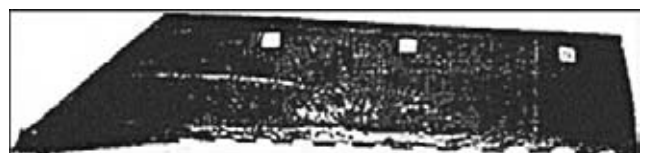

Figure 3. General view of surfaced plough [13]

To obtain bimetal tools, namely skim plough discs, it is proposed to apply the process of electric contact cladding by a wear-resistant strip [14]. To ensure the specified strength and elasticity disc knives are subjected to bulk quenching and tempering before cladding. Scale formed during rolling and heat treatment, is removed by etching in 20 % sulphuric acid solution with addition of 1 % inhibitor OP-1, heated up to the temperature of 70 °C. After etching, washing and drying, the disc is considered to be fit for strip cladding. The main disadvantages of this method are high labour consumption of preparatory operations, complexity of strip manufacturing from highly wear-resistant alloys, and low strength of welded layers.

Methods of cladding by explosion and rolling are used to strengthen the working surfaces of various flat parts, including tiller tools [15]. Advantages of explosion cladding include the high speed of the process, ability of joining metals, which cannot be produced or are difficult to produce by other methods, and relative simplicity of the technology (absence of the need for application of complex equipment) [15]. In Czechia explosion cladding technology was used in production of bimetal knives and other flat parts. Compared to traditional metallurgical process of casting cladding, explosion surfacing application is technically and economically substantiated

PWI developed and tried out a method of producing a wear-resistant bimetal at rolling of packets with powder PG-C1 [16], which is based on the principle of auto-vacuum pressure welding. In [17], this process was applied to produce tool bimetal with a cladding layer of PR 10R6M5 powder. The main disadvantage of the process is making a large-sized packet, related to the need for powder compaction to create a minimum volume of air in the packet cavity that is eliminated using powder pre-pressing. In [18] it is shown that at manufacture of bimetal sections for tiller tools cladding layer powder PG-S1 was first compacted by the method of hot isostatic pressing. However, industrial application of this technology is prevented by complexity and high labour consumption.

Works [7, 8, 19–21] describe the technology of plasma surfacing, which is applied in manufacturing of multiblade metal-cutting tools (end mills, etc.), as well as cutting edges of disc and flat cutters of various purpose. Powders of high-speed steels, as well as vanadium-containing alloys, are used as surfacing materials. This surfacing process allows comparatively easily con-

trolling the energy, heat and gas-dynamic parameters of a plasma jet in wide ranges, that eventually allows obtaining a deposited layer with specified physico-chemical and mechanical properties.

Technology of plasma-powder surfacing of paper cutting machine knives was developed. Resistance of batch-produced knives without surfacing is determined by their wearing time, dependent on strength, hardness, mechanical properties and some other characteristics of steel [7, 8, 20]. Blank for surfacing has a groove, which allows practically eliminating deformation after surfacing and edge effect arising at edge surfacing. Paper-cutting knives were surfaced by plasma-powder method for several steel types and alloys. After surfacing the blank is subjected to two-times annealing at the temperature of 540–560 °C, cutting, straightening and machining.

The advantages of plasma-powder surfacing are slight penetration of base metal, high quality of deposited layer, and possibility of deposition of thin layers (1–5 mm), using a wide range of filler materials. The disadvantages include relatively low efficiency and need for complex and expensive equipment, as well as high requirements to size distribution and shape of powder granules that makes its cost much higher, and this limits the application of this process.

To improve the performance of tiller tools (shredder knives, cultivator hoes, plough shares and other parts) PWI proposed spot strengthening using arc surfacing with PP-AN170 flux-cored wire [22]. Height of strengthening spot is equal to 1–3 mm, and base metal penetration depth is 2–4 mm. Surfacing is performed at reverse polarity. Penetration depth at spot strengthening is regulated by changing the current, voltage and arcing time. Figure 4 shows the general view of a plough share surfaced by flux-cored wire, before and after service. A disadvantage of this process is high labour and material costs for manufacturing the parts.

In [10, 23–25] the technology of strengthening the working surfaces of cultivator hoes by local strengthening is proposed. The essence of this method consists in that beads are deposited on the hoe outer surface by arc surfacing with 40 mm step at 25° angle to the hoe blade. Figure 5 shows the general view of the strengthened hoe. A disadvantage of this method are high labour costs and non-uniformity of bead deposition, which depends on welder's qualifications.

Also known is the technology of improvement of tiller tool wear resistance by carbonization of

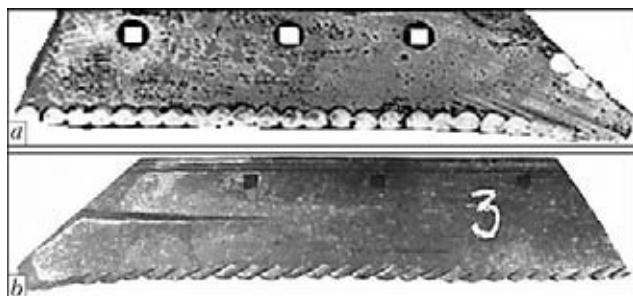

Figure 4. General view of surfaced share before (a) and after (b) service [22]

the surface layer by carbon electrode [26]. The principle of the method consists in that at carbon electrode contact with the part, carbon from the electrode goes into the base metal as a result of a spark discharge, forming on its surface a cementite layer, the hardness of which is much higher than that of base metal. This method was not widely accepted, because of the complexity of the technological process.

Works [11, 27] propose the technology of reconditioning and strengthening of plough shares by brazing on metal-ceramic plates. The essence of this method consists in that hard alloy plates in a continuous and intermittent arrangement are brazed-on from the face side of the share blade. To realize the process, a slot of 1.5–2.0 mm depth is milled out, then L63 braze alloy is placed into it, on which T15K6 and VK8 metal-ceramic plates are placed later on. Braze alloy heating is performed by the flame process, after brazing-on the share is placed into a thermo-insulating tank, heated up to the temperature of 620 °C, together with which it cools down to room temperature (Figure 6).

The main advantage of tool strengthening by metal-ceramic plates is lowering of draught resistance, which allows the machine working speed to be increased, thus increasing ploughing efficiency.

A disadvantage of this process are high cost and labour consumption related to the technology of part manufacturing.

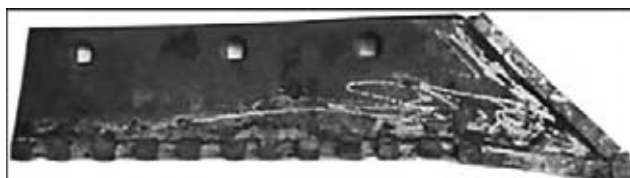

Figure 6. General view of share strengthened by metal-ceramic plates [11]

Other methods of tiller tool strengthening were also developed. They include surfacing using electronic amplifier [28], laser surfacing [29–31], etc. However, because of the complexity of the technology and lack of equipment, its imperfection and high cost, these processes have not found any industrial application so far.

Induction surfacing method is widely used for strengthening thin flat parts, including agricultural machinery tools. In [32–34] a technology of simultaneous induction surfacing of thin shaped discs over the entire working surface is proposed. Surfacing is performed using a special charge, consisting of a mixture of wear-resistant powder-like hard alloy and flux. Charge is applied on the part surface in the form of a layer of the required thickness (Figure 7). After that the part is placed inside the inductor (Figure 8), in which the power source is a high-frequency generator. At passage of high-frequency currents through the inductor, eddy currents are induced in the surface layers of the part to be surfaced, which heat the part, and the charge melts from its surface [32]. Advantages of the method include ability of thin layer deposition, high efficiency, ability of mechanization and automation of the process. The disadvantages are a high energy consumption, base metal overheating, and filler materials should be lower-melting than the base metal. Despite the above-said, this method is the most widely accepted in the enterprises manufacturing agricultural machinery, ploughs, skim ploughs, cultivator hoes, etc. [32].

To improve the labour conditions and process efficiency at induction surfacing of thin flat parts, in particular bits and hoes of cultivators, the authors developed semi-automatic machines



Figure 5. General view of hoe after local strengthening [10]

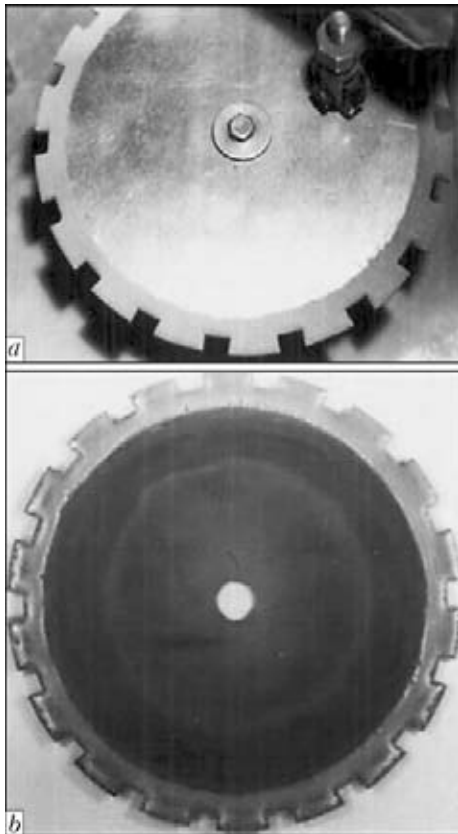

Figure 7. Device for charge filling (a) and surfaced disc (b) [34]

and automatic lines [33]. For surfacing of cultivator knives having a curvilinear cutting surface, carousel-type units are applied, in which wedge-shaped shears can be surfaced. The main disadvantage of these lines and machines is a low efficiency of the surfacing process proper, as well as low level of mechanization in terms of blank loading, charge filling and unloading.

To improve the efficiency of the process of induction surfacing of thin shaped discs – shedder knives of beet harvesters – by continuous-successive and simultaneous surfacing methods, production lines were developed and put into production [32], which allow mechanization and automation of the process, including loading and unloading of the blanks, and their movement in the rotor device, placing them in the positions of charge filling and surfacing and removal after surfacing.

Improvement of induction surfacing of thin flat parts is performed in the following directions: improvement of wear resistance of the deposited metal layer, optimization of the heating mode in order to save power, as well as design parameters of inductors and heating systems for surfacing discs of arbitrary diameters and surfacing zone dimensions, proceeding from technology needs, without allowing for shielding of electro-

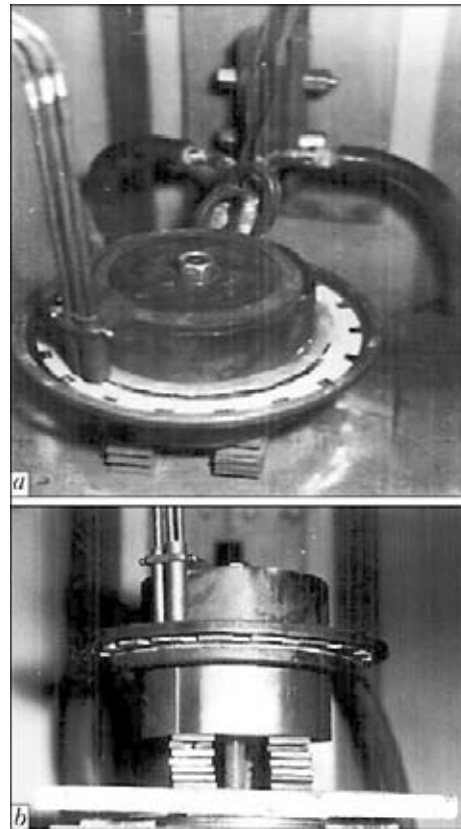

Figure 8. Device for surfacing the disc in two-turn circular inductor [34]: a – top view; b – side view

magnetic fields and allowing only for electromagnetic shielding, as well as combined shielding of electromagnetic and thermal fields simultaneously; mathematical simulation of the surfacing process to determine residual stresses, strains and displacements of parts; mechanization and automation of surfacing processes taking into account ecological compatibility of the process and protection of man from the impact of electromagnetic and thermal fields [32].

To improve wear resistance of deposited metal of tillers, in [35–39] it is proposed to apply part vibration after surfacing. The essence of this method consists in that a large number of microshocks with the respective frequency and amplitude of 0.5 mm, which are caused by the impact of processing tool oscillations, are successively applied to the deposited layer for 20 s. The main advantage at application of this technology is development of a uniform and more fine-grained structure of the deposited layer, that leads to 25 % increase of deposited metal hardness. High labour consumption and cost related to application of additional technological operations after surfacing, should be regarded as the disadvantages of this process.

Works [40–42] describe the technology of vibration treatment of welded joints of oil and gas

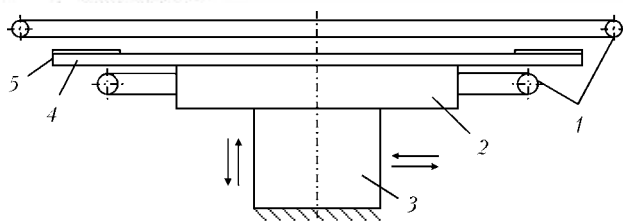

Figure 9. Schematic of induction surfacing of thin flat parts with vibration application during surfacing: 1 – inductor; 2 – table; 3 – vibrator (arrows show direction of vibration application); 4 – part; 5 – powder-like hard alloy

equipment. This technology allows lowering the level of residual stresses and strains, arising after welding. It, however, has not yet become widely accepted, because of the complex technological process and equipment.

Further improvement of induction surfacing technology is achieved using horizontal and vertical vibration to increase the wear resistance and lower the deformation of thin flat parts, which consists in that vibration at a certain frequency and amplitude (Figure 9) is introduced, when the powder-like wear-resistant hard alloy starts melting and it is continued up to its complete melting and solidification [43]. Wear resistance and lower deformations are achieved due to formation of a fine-grained structure and more favourable distribution of carbides in the deposited metal, compared to surfacing without vibration. The authors developed methods and devices for surfacing thin flat parts with application of horizontal and vertical vibrations. Conducted investigations of the structure, wear resistance and hardness of the deposited metal showed its advantages compared to the currently available methods of induction surfacing and need to develop a mathematical model of the process, which would allow assessment of the influence of mechanical vibrations on the physical essence of refinement of deposited metal structure and its service properties.

Results of improvement of the process of induction surfacing of agricultural machinery tools, conducted by the authors with introduction of horizontal and vertical vibration, were published in [43–46].

Thus, analysis of the modern surfacing methods showed that for thin flat parts of tillage agricultural machinery, including discs, with base metal and deposited layer thickness of 2.0–6.0 and 0.8–2.0 mm, respectively, the most widely accepted and promising method is induction surfacing without base metal mixing with the deposited metal. This method is the most readily adaptable to fabrication due to application of simple equipment, simplicity of the surfacing

process proper, and no requirement of a high qualification of surfacing operators, and possibility of process mechanization and automation (that is important in batch production). It is being constantly improved in terms of increasing the efficiency, wear resistance, and uniformity of deposited metal layer thickness, power saving, as well as lowering part deformation.

1. Tkachev, V.N. (1971) *Wear and increase in service life of agricultural machine parts*. Moscow: Mashinostroenie.
2. Bol, A.A., Leskov, S.P. (1985) Induction surfacing of parts in agricultural machine-building. In: *Surfacing. Experience and efficiency of application*. Kiev: PWI.
3. Vishnevsky, A.A., Kostylev, Yu.A., Ostrov, D.D. (1978) Technology of fabrication of built-up disc cutters. In: *Surfacing of parts of metallurgical and mining equipment*: Coll. Moscow: NIInformtyazhmash.
4. Pulka, Ch.V. (2003) Hardfacing the working components of tillage and harvesting agricultural machinery (Review). *The Paton Welding J.*, **8**, 35–40.
5. Rabinovich, A.Sh. (1962) *Self-sharpening plough shares and other tiller tool parts of machines*. Moscow: GOSNITI.
6. Nikolaenko, M.R., Rymorov, E.V. (1976) *New technological processes of arc and contact surfacing of rapidly wearing parts of building and road machines*. Moscow: TsNIITEstrojmach.
7. Gladky, P.V., Pereplyotchikov, E.F., Ryabtsev, I.A. (2007) *Plasma surfacing*. Kiev: Ekotekhnologiya.
8. Bouaifi, B., Gebert, A., Heinze, H. (1993) Plasmapulverauftragschweißung zum Verschleisschutz abrasiv beanspruchter Bauteile mit Kantenbelastung. *Schweissen und Schneiden*, **9**, 506–509.
9. Denisenko, M.I., Vojtyuk, V.D. (2011) Increase in service reliability of tools of tillage machines. Pt 1 *Nauk. Visnyk Nats. Univ. Bioresursiv*. Series Technique and power engineering of agricultural sector, Issue 166, 274–284.
10. Kobets, A.S., Pugach, A.M. (2010) Methods and processes of increase in wear resistance of tools of cultivators. *Visnyk Dnipropetr. DAU*, **1**, 61–63.
11. Kuznetsov, Yu.A., Goncharenko, V.V. (2007) Repair and strengthening of plough shares with cermet plates. *Vestnik Ros. GAZU*, **2**, 122–123.
12. Turkin, V.P., Putilin, V.G., Nikolaenko, M.P. et al. (1978) Electric contact surfacing of disk cutters. *Avtomatich. Svarka*, **2**, 74–76.
13. Volkov, D.A. (2012) *Improvement of technology of sparcely-alloyed surfacing of wear-resistant alloy using flux-cored wire*: Syn. of Thesis for Cand. of Techn. Sci. Degree. Kramatorsk.
14. Mamuliya, G.E., Murov, G.F., Tyulenev, V.P. et al. (1984) Contact cladding of tillage machine tools. *Svarochn. Proizvodstvo*, **2**, 37–39.
15. Gelman, A.S., Tsemakhovich, B.D., Chudpovsky, A.D. et al. (1978) *Explosion cladding of steel*. Moscow: Mashinostroenie.
16. Ryabtsev, I.A. (1981) Bimetallic rolled metal with clad layer of granular powder PG-S1. In: *Abstr. of 3rd Republ. Sci.-Techn. Conf. on Current Methods of Surfacing and Consumables* (Kharkov, 1981), 9–10.
17. Kalner, V.D., Goryushina, M.N., Sichuzhnikova, A.A. (1984) Processes of interaction in interface of bimetallic billets produced by method of nonsintered powder rolling. *Metallovedenie i Termich. Obrab. Metallov*, **3**, 28–29.
18. Fedorov, B.N., Osadchy, V.A., Tits, M.Yu. et al. (1975) Prospects of application of compact materials in bimetallic parts of agricultural machine tools. *Traktory i Selkhoz mashiny*, **9**, 39–41.
19. Ryabtsev, I.A. (2004) *Surfacing of machine and mechanism parts*. Kiev: Ekotekhnologiya.

20. Pereplyotchikov, E.F., Ryabtsev, I.A., Gordan, G.M. (2003) High-vanadium alloys for plasma-powder cladding of tools. *The Paton Welding J.*, **3**, 14–17.
21. Pereplyotchikov, E.F. (2005) Plasma cladding. *Remont, Vosstanovlenie, Modernizatsiya*, **12**, 35–40.
22. Denisenko, M., Opalchuk, A. (2011) Wear and increase in service life of agricultural machine tools. Pt 2. *Visnyk Ternopil. NTU*, **2**, 201–210.
23. Kobets, A.S., Kobets, O.M., Pugach, A.M. (2011) Field investigations of wear of hoes with local strengthening. *Visnyk Khark. NTU im. P. Vasylenka*. Series Mechanization of agricultural production, **107**, 208–213.
24. Mikhalchenkov, A.M., Tyureva, A.A., Mikhalchenkova, M.A. (2007) Increase in wear resistance of plough shares by deposition of strengthening beads in zone of maximum wear. *Remont, Vosstanovlenie, Modernizatsiya*, **9**, 17–19.
25. Vasilenko, M.O. (2008) Prospects of local strengthening application in manufacturing and repair of tools. *Tekhnika APK*, **1**, 29–31.
26. Kirgizov, V.E., Shishkin, G.M., Baldanov, K.P. et al. (2010) Increase in service life of plough shares in repair by carbon electrode surfacing. *Vestnik IrGSKhA*, Issue 38, 65–70.
27. Goncharenko, V.V., Ferbyakov, A.V., Kuznetsov, Yu.A. et al. (2006) Repair and strengthening of share cutting edge by brazing of cermet plates. *Mekhanizatsiya i Elektrifikatsiya Selsk. Khoz.*, **11**, 21–22.
28. Fominsky, L.P., Levchuk, M.V., Bajsman, A.F. et al. (1987) Surfacing of agricultural machine tools using electron accelerator. *Svarochn. Proizvodstvo*, **11**, 4–6.
29. Ivashko, V.S., Yaroshevich, V.K., Luzan, P.G. et al. (2006) Strengthening of rapidly-wearing parts of tillage machines. *Mizhvidom. Nauk.-Tekhn. Zbirnyk Kirovograd. NTU*. Series Design, manufacturing and service of agricultural machines, Issue 39.
30. Kovalenko, V.S., Merkulov, G.V., Strizhak, A.I. (1981) *Laser beam strengthening of parts*. Kiev: Tekhnika.
31. Solovykh, E.K., Aulin, V.V., Bobrytsky, V.M. (2005) Analysis of wear pattern of tillage part edges and increase in their resource using laser technologies. *Design, manufacturing and service of agricultural machines*, Issue 35, 153–159.
32. Pulka, Ch.V. (2006) *Technological and power efficiency of induction melting of thin steel discs*: Syn. of Thesis for Dr. of Techn. Sci. Degree. Kiev.
33. Shably, O.M., Pulka, Ch.V., Korol, O.I. (2008) Main directions in induction surfacing of agricultural machine tools. *Visnyk Ternopil DTU*, **13(4)**, 100–109.
34. Shably, O.M., Pulka, Ch.V., Senchishin, V.S. et al. (2011) Development of energy-saving heating system for induction surfacing of agricultural machine parts. *Ibid.*, **4**, 107–120.
35. Bilovod, O.I., Dudnikov, A.A. (2007) To problem of wear resistance of tools of beet harvesters. *Visnyk Khark. DTU im. P. Vasylenka*. Series Mechanization of agriculture, Issue 59 (1), 288–293.
36. Dudnikov, I.A., Kivshik, A.P., Dudnikov, A.A. (2009) *To problem of influence of vibration treatment on material deformation of treated parts*: Transact. Issue 39, 167–169.
37. Dudnik, V.V. (2011) Evaluation of structure of strengthened layer of pough edge. *Vostochno-Evrop. Zhurnal Pered. Tekhnology*, **4/7**, 4–6.
38. Dudnikov, A.A., Gorbenko, O.V., Bilovod, O.I. (2006) Strengthening treatment with vibrating deformation. In: *Transact. of Lugansk NAU*, **68/91**, 86–88.
39. Babichev, A.P., Babichev, I.A. (2008) *Principles of vibration technology*. Rostov-na-Donu.
40. Sutyryn, G.V. (1975) Study of mechanism of low-frequency vibration impact on weld pool crystallization. *Avtomatich. Svarka*, **5**, 7–10.
41. Khafizova, O.F., Bolobov, V.I., Fajrushin, A.M. et al. (2011) To influence of vibration treatment on mechanical properties of dissimilar welded joints. *Neftegazovoe Delo*, **1**; http://www.ogbus.ru/authors/Khafizova/Khafizova_1pdf/
42. Salmin, A.N., Fajrushin, A.M., Ibragimov, I.G. (2010) Study of influence of vibratons during welding on operational strength and mechanical properties of 11Kh11N2V2MF steel welded joints. *Ibid.*; http://www.ogbus.ru/authors/Salmin/Salmin_1.pdf
43. Pulka, Ch.V., Shably, O.N., Senchishin, V.S. et al. (2012) Influence of vibration of parts on structure and properties of metal in surfacing. *The Paton Welding J.*, **1**, 23–25.
44. Pulka, Ch.V., Senchishin, V.S. *Device for surfacing of thin shaped discs*. Pat. 59994 UA. Int. Cl. V23K 13/00. Fil. 05.11.2010. Publ. 10.06.2011.
45. Pulka, Ch.V., Senchishin, V.S. *Method of surfacing of steel parts*. Pat. 64371 UA. Int. Cl. V23K 13/00. Fil. 18.03.2011. Publ. 10.11.2011.
46. Shably, O.N., Pulka, Ch.V., Senchishin, V.S. et al. *Method of surfacing of flat steel parts*. Pat. 54204 UA. Int. Cl. V23K 13/00. Fil. 28.05.2010. Publ. 25.10.2010.

NEW BOOK

(2012) **Metallurgy of Arc Welding, and Welding Consumables** (in Russian). ISBN 978-966-360-203-5. Compiled by I.K. Pokhodnya, A.S. Kotelchuk. Kiev: Akadempriodika, 526 pp.

Book includes 120 articles of associates of Department for Study of Physical-Chemical Processes in Welding Arc at the E.O. Paton Electric Welding Institute of the NAS of Ukraine. This book generalizes the half-century experience of the Department research activity. The presented articles cover a wide scope of problems of metallurgy of the fusion arc welding and development of welding consumables.

Book can be interesting and useful for specialists and scientific-technical staff, as well as for post-graduates and students of higher education institutions, studying the problems of metallurgy of arc welding and dealing with the development of welding consumables.

Kindly send the orders for the book to the Editorial Board of «The Paton Welding Journal»
Phone / Fax: (38044) 200-82-77, e-mail: journal@paton.kiev.ua

