

EFFECT OF TELLURIUM ON MICROSTRUCTURE OF LOW-ALLOY CAST IRON DEPOSITED BY ELECTROSLAG METHOD IN CURRENT-CARRYING MOLD

Yu.M. KUSKOV¹, F.K. BIKTAGIROV¹ and M.A. FESENKO²

¹E.O. Paton Electric Welding Institute of the NAS of Ukraine

11 Kazymyr Malevych Str., 03150, Kyiv, Ukraine. E-mail: office@paton.kiev.ua

²National Technical University of Ukraine «Igor Sikorsky Kyiv Polytechnic Institute»
37 Peremohy Prosp., 02056, Kyiv, Ukraine

Cast iron is one of the main structural materials, having a number of valuable service properties, in particular, wear resistance. Improvement of this characteristic is usually achieved by changing the structure of cast iron due to introduction of expensive alloying elements into its composition. The experiments carried out showed the possibility of transforming gray low-alloy cast iron to chilled wear-resistant one, due to modification of the deposited metal by small portions of tellurium powder. Electroslag surfacing was carried out in a current-carrying mold with melting of filler in the form of chips of low-alloy cast iron in the slag layer and additionally introducing flux-cored wire with a charge, containing tellurium powder, into the slag pool. 6 Ref., 9 Figures.

Keywords: electroslag surfacing, current-carrying mold, low-alloy cast iron chips, tellurium, metal structure

Tellurium belongs to metalloids and is applied in various industries, namely chemical, glass, semi-conductor, rubber, metallurgical, etc. In particular, tellurium is used in metallurgy to lower nitrogen absorption by liquid cast iron and steel. It effectively refines the grain in steel, lowers the porosity of castings from steel and cast iron [1]. Tellurium microadditives significantly improve the structure, mechanical properties and formability of cast iron and steel [2].

A special feature of this element, which can be used during performance of wear resistant surfacing, is the effect of small quantities of tellurium from 0.005 up to 0.1 % on stabilization of carbides, for instance it is possible to produce chilled cast iron instead of gray cast iron during wear-resistant surfacing [3].

Interesting is the experience for manufacturing cast iron rolling rolls from unalloyed and medium-alloyed (2.0–4.5 % Ni and 0.5–1.5 % Cr) cast irons with addition of small quantities of tellurium filler to liquid metal, gained as far back as in 1950s [4]. It is found that it strongly slows down the graphitization and increases the depth of chilling. Adding 0.0001 % tellurium is equivalent to lowering silicon content by 0.04 %, i.e. tellurium slows down graphitization 400 times stronger than silicon does. Therefore, in order to improve the quality of the roll chilled layer, additive of 0.0002–0.0006 % tellurium is quite sufficient, that is regarded to be optimum for passivation of nonmetallic centers of graphitization in roll melts. On the other hand, excess of tellurium acts as a carbide-stabilizing factor. And while for rolls an increased quantity of carbides is undesirable in terms of their per-

formance, at deposition on the parts of relatively thin layers, having a carbide component in their structure, it is possible not only to significantly increase the wear resistance of cast iron, but also essentially improve the economic indices of surfacing.

This work is devoted to studying structure formation in metal produced by electroslag surfacing with low-alloy cast iron chips with addition of small quantities of tellurium.

In terms of technology, it is the most rational to solve such a task with application of a current-carrying mold (CCM) in surfacing [5]. Here, the open

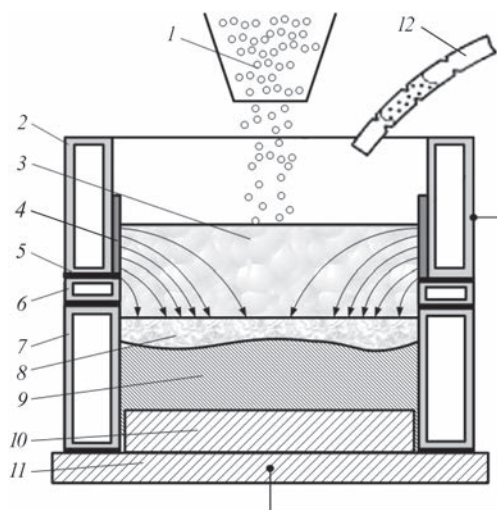

Figure 1. Schemes of electroslag surfacing in CCM with discrete filler (chips) with additional feeding of wire, containing tellurium powder charge, into the slag pool: 1 — discrete filler (chips); 2, 6, 7 — current-carrying, intermediate and forming sections of the mold, respectively; 3 — slag pool; 4 — protective lining; 5 — insulating gasket; 8 — metal pool; 9 — deposited metal; 10 — billet; 11 — tray; 12 — flux-cored wire with tellurium powder charge

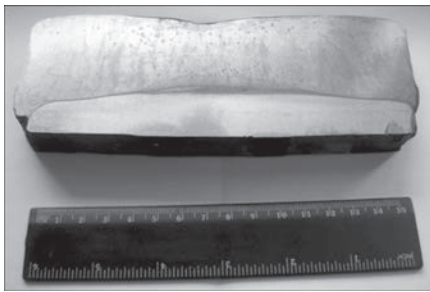

Figure 2. Macrosection of surfaced billet

mirror of the slag pool allows successfully combining addition of deposited metal chips and tellurium into the metal pool through the slag.

Surfacing with chips was performed on a steel billet of 170 mm diameter in CCM of 180 mm diameter. Vibrodosimeter was used as a device for chips feeding [6]. Considering the fineness of the tellurium powder, its pouring onto the slag pool surface could lead both to its nonuniform distribution in the metal pool and to greater loss during surfacing. Therefore, addition of tellurium powder into the slag pool was performed as follows. A tubular rod was formed from a steel strip of 0.5×12 mm size, inside which the tellurium powder was placed. To avoid its pouring out or moving inside the rod, the rod was pinched approximately every 25 mm. During surfacing two processes proceeded simultaneously: continuous feeding of the chips and periodic dipping of the rod end into the slag. The calculated value of the added tellurium was equal to 0.2 % of that of the deposited cast iron. The surfacing scheme and longitudinal macrosection of the surfaced billet are shown in Figures 1 and 2, respectively.

Results of measurement of deposited metal Rockwell hardness (*HRC*) are given in the macrosection sketch (Figure 3). Measurements of Brinnel hardness (*HB*) were additionally performed to assess the average hardness of the composite metal (matrix + inclusions).

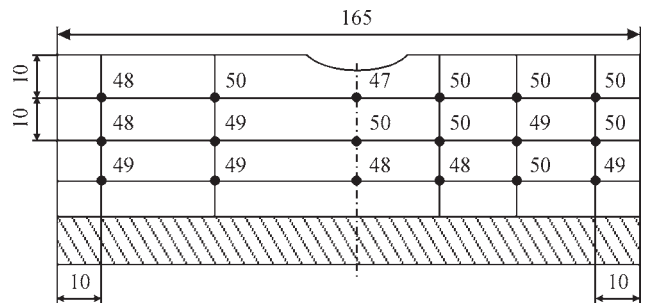

Figure 3. Sketch of a macrosection with hardness values (*HRC*) across the deposited layer section

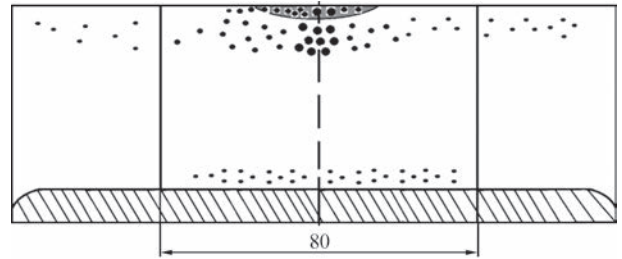

Figure 4. Sketch of a macrosection with inclusions located on its surface

Metallographic investigations were performed in optical microscope MMR-4, having an attachment, allowing taking photos of the studied zones of microsections (section No.3 — along the deposited layer axis; section No.1 — metal crystallized at the mold wall; section No.2 — metal located approximately in the middle of the distance between zones 1 and 3), by analogy with the zones of microhardness measurement (see Figure 3). Hardness meter PMT-3 was used for measurement of microhardness of the structural components.

Assessment of the deposited metal structure. According to the results of chemical analysis, residual tellurium content in the deposited metal is equal to 0.079–0.112 %. Deposited metal is dense, although shrinkage approximately 5 mm deep is present in the

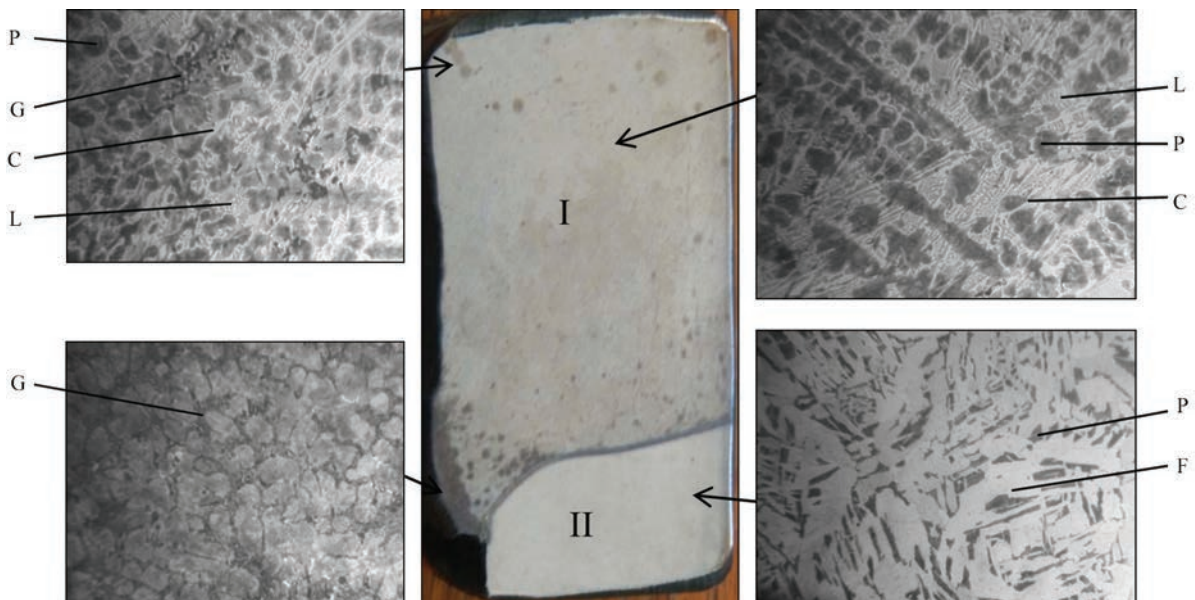

Figure 5. Microstructure (×100) of deposited metal of microsection No.1: I — deposited metal; II — base metal



Figure 6. Microstructure ($\times 100$) of fusion zone of microsection No.1 (for description of *a-c* see the text)

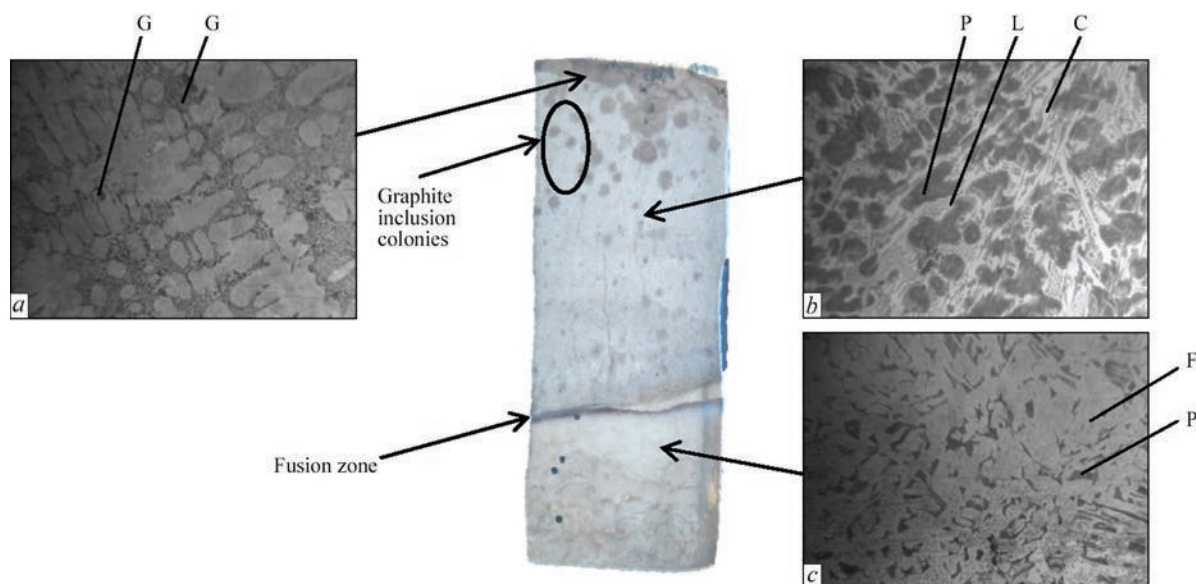

Figure 7. Microstructure ($\times 100$) of deposited metal of microsection No.2

layer upper part along its axis. Nonuniformly distributed round-shaped inclusions of not more than 1–2 mm diameter are observed on the section surface (Figure 4). These inclusions are, mainly, located in the central zone of the section on length $L = 80$ mm. Larger inclusions and their conglomerate are concentrated in the shrinkage cavity zone. Smaller-size inclusions are located at the fusion zone of base and deposited metals. In the part of the deposited layer, which was crystallized closer to mold walls ($L = 40$ mm) inclusions are practically absent. Measurements of inclusion microhardness allowed identifying them as graphite precipitates with $HV1 = 1.1\text{--}1.3$ GPa.

The fusion zone is a line slanting at the edges towards the base metal (penetration is equal to approximately 5 mm). Such a pattern of base metal penetration corresponds to distribution of current lines in the slag pool and nature of metal pool formation at surfacing in the CCM (see Figure 1).

Depending on penetration depth, the change of macrohardness (HB) of the transition zone from the deposited to the base metal in sections 1–3 is equal to: No.1 — 440–128; No.2 — 392–111; No.3 — 440–278.

Assessment of microstructure zones in microsections 1–3.

Sample No.1 (Figure 5). The main components of the deposited metal structure are cementite (C), ledeburite (L) and pearlite (P). Rare inclusions of interdendritic graphite (G) are found. Microhardness of structural components is characterized by the following values (GPa): C — 4.8–6.45; L — 4.2–4.4; P — 3.1–3.2; G — 1.1–1.3. On the whole, presence of such a range of structural components corresponds to the structure of chilled wear-resistant cast iron.

The zone of metal fusion (Figure 6) is presented in the form of several transition layers: base metal (*a*) — ferritic-pearlitic steel (*c*), a narrow band ($\delta = 1\text{--}2$ mm) of metal of a composition produced as a result of mix-

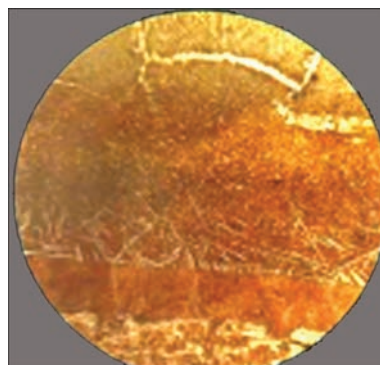

Figure 8. Microstructure ($\times 30$) of fusion zone of microsection No.2

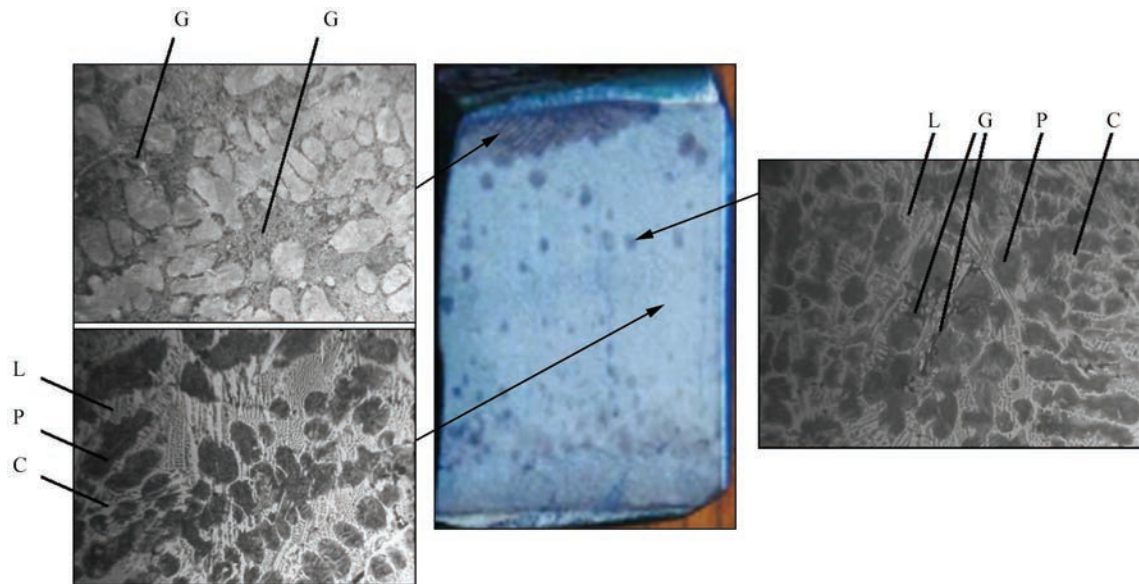

Figure 9. Microstructure ($\times 100$) of deposited metal of microsection No.3

ing of the deposited and base metal (*b*) — a layer with a small quantity of characteristic martensite or Widmanstätten needles — a layer of deposited cast iron.

Sample No. 2 (Figure 7). Structure of this part of the deposited metal largely corresponds to that of sample No.1. The difference consists in that there is a large number of graphite inclusions, particularly in the upper part of the layer. If we exclude the graphite inclusion colonies from consideration, such a structure also corresponds to that of chilled cast iron.

Metal fusion zone (Figure 8) also consists of several layers, but layer boundaries are clearer, that is attributable to smaller penetration of base metal.

Sample No. 3. Deposited metal of this sample has the most complex structure, formed as a result of some features of the applied technique of ESS in CCM. As one can see from Figure 1, the discrete surfacing material (chips in our case) is fed on the slag pool surface in the vicinity of its vertical axis (in the mold center). In the case, if the filler feed speed does not correspond to the accepted electric surfacing mode, or in other words to pool thermal conditions, the following situation is in place. On the one hand, not the total volume of the fed filler has enough time to melt completely, on the other, the forming column of unmelted or incompletely melted filler prevents uniform distribution of tellurium particles and its interaction with liquid metal in its entire volume.

These are exactly the reasons for structural nonuniformity across the deposited layer cross-section, obtained during surfacing. More over, in this experiment, the last portions of chips not only did not melt completely, but concentrated in the narrow surface zone of

the shrinkage cavity. As a result, in the area where this accumulation occurred, the metal structure consists of platelike graphite, cementite, ledeburite and pearlite. Here, both in the accumulation zone and in the presence of individual coarse inclusions, graphite is distributed in the form of highly ramified branches located in interdendritic space. As a result, a structure of mottled cast iron ($G + P + C + L$) is observed in those areas where graphite is present in sufficiently large quantity. In areas with its lower content, the structure corresponds to chilled cast iron ($P + C + L$).

Thus, performed research proved the possibility of producing wear-resistant cast iron in electroslag surfacing in CCM, by modifying by tellurium the liquid metal of the deposited filler in the form of chips of low-alloyed cast iron. However, to achieve a uniform interaction of tellurium with the entire volume of liquid metal, it is necessary to provide during surfacing the correspondence between mass velocity and dimensions of the fed filler to electric modes of ESS process.

1. Kindyakov, P.S., Korshunov, B.G., Fedorov, P.I., Kislyakov, I.P. (1976) *Chemistry and technology of rare and scattered elements*. Pt 3. Moscow, Vysshaya Shkola [in Russian].
2. (1985) *Properties of elements: Refer Book*. Ed. by M.E. Dritsa. Moscow, Metallurgiya [in Russian].
3. Houdremont, E. (1966) *Special steels*. Vol. 3. Moscow, Metallurgiya [in Russian].
4. Krivosheev, A.E. (1957) *Cast rolls*. Moscow, Metallurgizdat [in Russian].
5. Kuskov, Yu.M., Gordan, G.N., Bogajchuk, I.L., Kajda, T.V. (2015) Electroslag surfacing using discrete materials of different methods of manufacture. *The Paton Welding J.*, **5–6**, 30–33.
6. Shchupak, G.B., Us, V.I., Kuskov, Yu.M. et al. (1993) Dosing system of filler materials in electroslag technology. *Problemy Spets. Elektrometallurgii*, **1**, 29–31 [in Russian].

Received 09.04.2019